

TOSVERT VF-AS1/PS1

PG FEEDBACK BOARD Instruction Manual

1. INTRODUCTION.....	4
2. NAMES OF THE PARTS ON THE BOARD.....	5
3. CONNECTION TO THE INVERTER	6
3.1. Installation to the Inverter.....	6
3.2. Wiring.....	7
4. FUNCTIONAL DESCRIPTION	8
4.1. Vector control with sensor	8
4.1.1. PG feedback wiring.....	8
4.1.2. Selection of encoder type	11
4.1.3. Vector control setting parameter	12
4.1.4. Monitoring method for feedback amount.....	13
4.1.5. Confirmation of PG's rotational direction	14
4.1.6. PG disconnection detection function	14
4.1.7. Speed abnormality detect function	15
4.1.8. Accuracy of speed control	15
4.1.9. Stop position control function (VF-AS1 only).....	16
4.2. Pulse input command (speed command selection).....	18
4.2.1. Pulse command connection method	18
4.2.2. Pulse input setting parameter.....	20
4.2.3. Monitoring method of pulse input command	21
5. EXTERNAL VIEW	21
6. SPECIFICATION.....	22
7. OPTION CABLE.....	23
8. WARRANTY.....	25

NOTE



1. Make sure that this instruction manual is delivered to the end user of the PG feedback board.
2. Read this manual before installing or operating the inverter unit, and store it in a safe place for reference.

* The data given in this manual are subject to change without notice.

Safety Precautions

On the inverter and in its instruction manual, important information is contained for preventing injuries to users and damages to assets and for proper use of the device. Read the instruction manual attached to the inverter along with this instruction manual for completely understanding the safety precautions and adhere to the contents of these manuals.





Explanation of markings

Marking	Meaning of marking
 Danger	Indicates that errors in operation may lead to death or serious injury.
 Warning	Indicates that errors in operation may lead to injury (*1) to people or that these errors may cause damage to physical property. (*2)





(*1) Such things as injury, burns or shock that will not require hospitalization or long periods of outpatient treatment.

(*2) Physical property damage refers to wide-ranging damage to assets and materials.



Meanings of symbols

Marking	Meaning of marking
	Indicates prohibition (Don't do it). What is prohibited will be described in or near the symbol in either text or picture form.
	Indicates something mandatory (must be done). What is mandatory will be described in or near the symbol in either text or picture form.
	Indicates danger. What is dangerous will be described in or near the symbol in either text or picture form.
	Indicates warning. What the warning should be applied to will be described in or near the symbol in either text or picture form.



■ Handling in general

 Danger	
 Never Disassemble	<ul style="list-style-type: none"> ▼ Never disassemble, modify or repair the inverter. Disassembling the inverter could cause electric shocks, fire or injuries. Request your TOSHIBA dealer for repairs.
 Prohibited	<ul style="list-style-type: none"> ▼ Do not remove connectors when the power is on. It could lead to electric shocks. ▼ Do not put or insert foreign objects such as waste cable, bars, or wires into the inverter. It could lead to electric shocks or fire. ▼ Do not splash water over the inverter. It could lead to electric shocks or fire.
 Mandatory	<ul style="list-style-type: none"> ▼ Wiring should be conducted after turning the inverter power off. ▼ Turn off the power immediately in case any abnormalities such as smokes, smells or abnormal noise are found. Neglect of these conditions could lead to fire. Ask your TOSHIBA dealer for repairs.



■ Transportation and Installation

 Danger	
 Prohibited	<ul style="list-style-type: none"> ▼ Do not install or operate the inverter if it is damaged or any part is missing from it. Operating the inverter in a defective condition could lead to electric shocks or fire. Ask your TOSHIBA dealer for repairs. ▼ Do not put any inflammable material near the inverter. It could catch fire if the inverter sparks because of a breakdown and the like. ▼ Do not install the inverter where it could be splashed with water and the like. It could lead to electric shocks or fire. ▼ When installing this option, be careful not to touch the leads from parts on the circuit board. Doing so could result in injury.
 Mandatory	<ul style="list-style-type: none"> ▼ Inverter must be used under environmental conditions prescribed in this instruction manual. Using the inverter under conditions not specified by the instruction manual could lead to breakdown.



■ Wiring

 Danger	
 Mandatory	<ul style="list-style-type: none"> ▼ Be sure to perform the following preparatory work before proceeding to wiring. <ul style="list-style-type: none"> • Turn the power off. • Wait 15 minutes or more after turning the power off and confirm that the charge lamp (on the inverter) is extinct. • Using a circuit tester that has a D.C. voltage measuring capacity of more than 800V, check to see that the voltage remaining in the D.C. main circuit (between PC and PA) is below 45V. <p>Failure to do this preparation could lead to electric shocks.</p> <ul style="list-style-type: none"> ▼ Tighten the terminal board fixing screws at the specified torque. <p>Failure to do this could lead to fire.</p>

■ About operation

 Danger	
 Prohibited	<ul style="list-style-type: none"> ▼ Do not touch inverter terminals when they are energized even if the motor is halted. Touching terminals while the power is energized could lead to electric shocks. ▼ Do not wipe the body with a wet cloth. It could lead to electric shocks. ▼ Do not pull on the cable It could cause damage or error.

■ About disposal of Inverter

 Warning	
 Mandatory	<ul style="list-style-type: none"> ▼ Dispose of the inverter as an industrial waste. Unless it is disposed of as an industrial waste, it will become risks for human injury.

Notes on use

Notes	
	<ul style="list-style-type: none"> ▼ Do not install the inverter where the temperature or the humidity will change rapidly. ▼ Keep a distance of 20cm or more between the inverter's power cable and the encoder cable. Or the inverter might malfunction because of noise.

1. Introduction

Thank you for purchasing the PG Feedback Board (PGFB board) for Industrial Inverter, TOSVERT VF-AS1/PS1 series.

By the use of this optional board, it is possible for the VF-AS1/PS1 series inverters to conduct pulse row speed command and vector control with sensor. This instruction manual describes installation and application of "PGFB board". Read this manual carefully before using the board.

Keep this manual near at hand of the operator who uses the "PGFB Board" for future reference in the maintenance and inspection.

* Please use this option for VF-AS1 that the software version (CPU version 1) is V124 or successor.

When it is used with the V106 or earlier software and the number of pulse inputs except 1024, the motor rotation may become unstable.

Refer to the instruction manual of the inverter for the check method of the version.

<Description of the PGFB Board type>

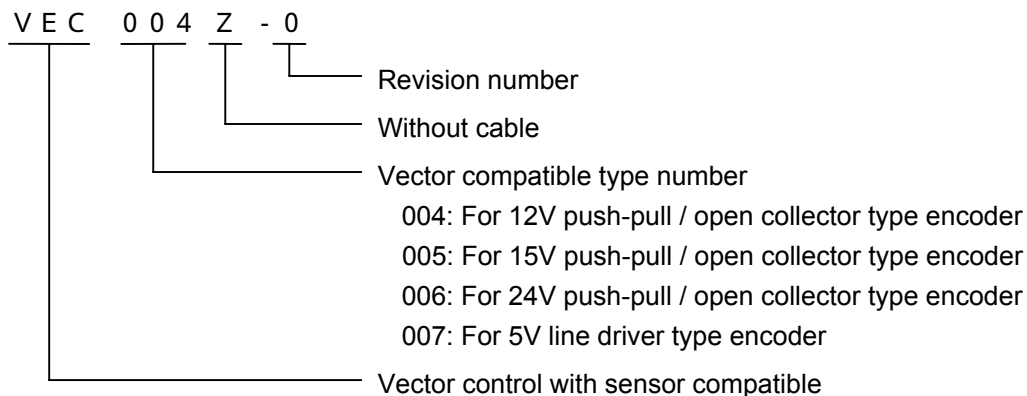

<Confirmation on Accessories>

Following accessories are the options to the PGFB Board.

Upon unpacking, confirm on the following items:

- ◎ Instruction Manual: E6581319(English)
- ◎ PGFB Board (printed circuit board), Detachable TB

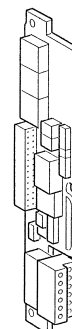
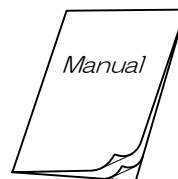

2. Names of the Parts on the Board

External views of the PGFB Board are described in this section together with the names of parts on the board.

■ External views and names of parts on the board (terminals)

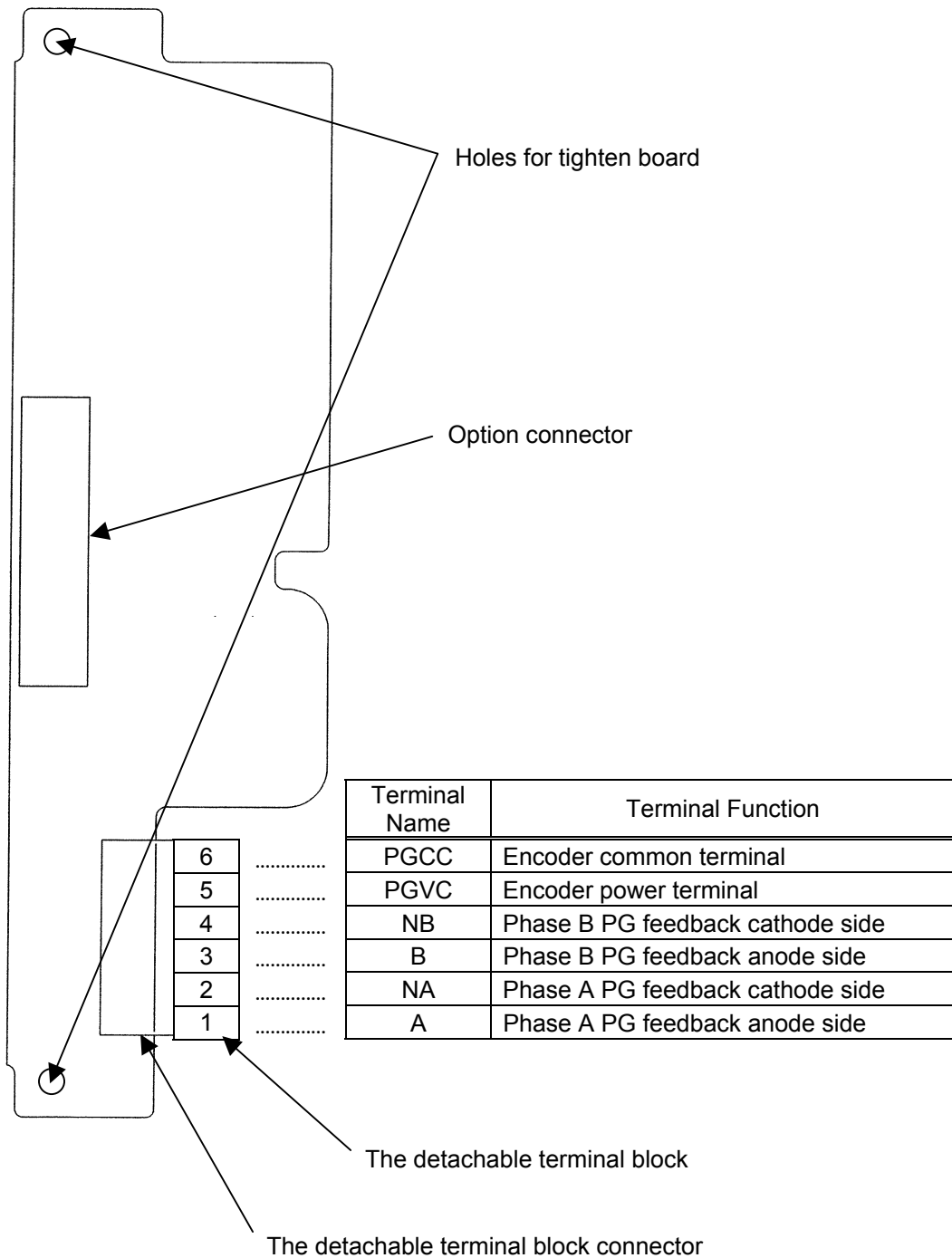

3. Connection to the Inverter

Install the PGFB to the inverter according to the procedures below.

3.1. Installation to the Inverter

(1) Confirm that the all power of the inverter are turned off beforehand.

Note: Wait 15 minutes or more after turning the power off and confirm that the charge lamp on the inverter is unlit.

(2) Fastening the board on the inverter

1. Inset the minus screw driver into the upper left hole of the front cover. And pull down and unlock the hook.
2. Pull down and unlock the right hook of the front cover like the left hook.
3. Pull the front cover upper side, and remove the front cover.
4. Install and push the PGFB board along with the guide of the board as the terminal of the encoder wiring is a former side. It confirms that an optional circuit board connects it firmly with the inverter. Confirm that the plastic projection of the plastic body is put in the hole of the circuit board fixation over and under.
5. Put together the hook of the bottom part of the front cover and the bottom part of the body, and it gains the front cover to the body. And attach the front cover to the body.

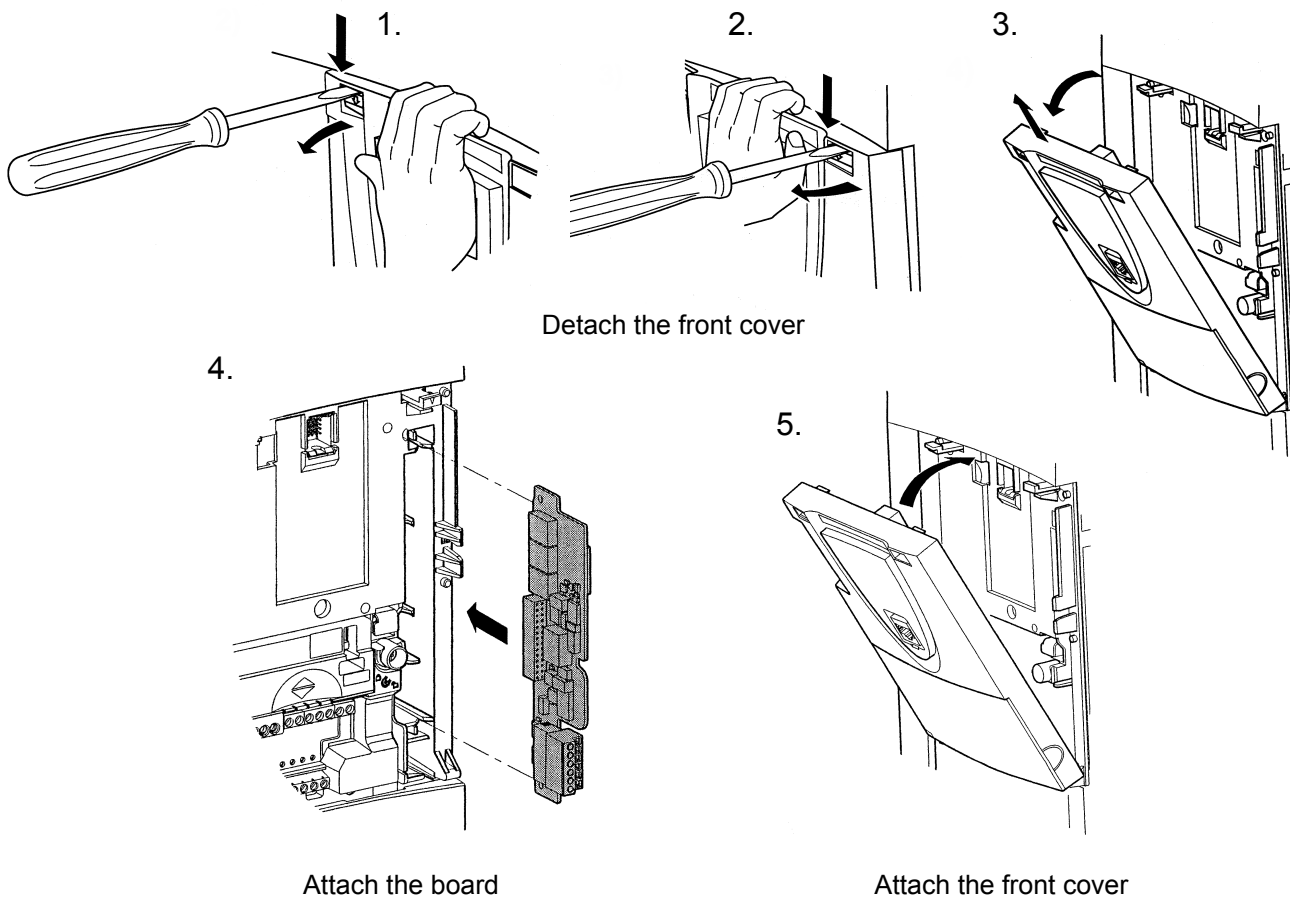

3.2. Wiring

When conducting wiring, follow the instructions below.

- Use twisted pair shield wire for signal lines.
- Applicable wire size is 0.2 to 0.75 mm².
- Peel the wire end for about 5 mm.
- When wiring, use a screw driver with the blade thickness of about 0.4 mm and width of about 2.5 mm.
- Tightening torque for terminal base should be about 0.22 to 0.25 N·m.
- Never bind the signal lines and main circuit wiring.

■ <Encoder output format and PGFB board interface>

	Encoder output format	PGFB board wiring	PGFB board interface
Complementary	<p>Note: · In case of the two-phase input, the disconnection detection by the hardware is valid. (F376=2, F377=2) · In case of the single-phase input, the disconnection detection only by the software is valid. (F376=1, F377=1)</p>	<p>Note: · The disconnection detection only by the software is valid. (F377=1)</p>	<p>VEC004Z (12V) VEC005Z (15V) VEC006Z (24V)</p>
Open collector	<p>Note: The disconnection detection only by the software is valid. (F377=1)</p>		
Line driver	<p>26LS31 equivalent</p> <p>Note: · In case of the two-phase input, the disconnection detection by the hardware is valid. (F376=2, F377=2) · In case of the single-phase input, the disconnection detection is invalid. (F376=1, F377=0)</p>		<p>VEC007Z (5V)</p>

4. Functional Description

In this section, functions added by the installation of the PGFB board, on top of the standard inverter functions, are described.

4.1. Vector control with sensor

Using the pulse-row feedback signal from the encoder installed on the motor shaft or load rotation shaft, vector control with sensor can be conducted.

Speed control operation : 0 speed to 150% torque, speed control range 1:1000 (1000 ppr-PG)
speed accuracy $\pm 0.02\%$ (50Hz base digital input)

Torque control operation : Torque control accuracy: $\pm 10\%$ (torque control range: -100% to 100%)

4.1.1. PG feedback wiring

■ In case of VEC004, VEC005Z, VEC006Z (complementary/open collector)

As for the pulse input signals, A and NA are connected for Phase A, B and NB are connected for Phase B.

The polarity of the pulse input signals should be as follows:

- + side: A, B
- side: NA, NB

The encoder installation direction and signal line wiring should be determined so that the signal that are fed back from the encoder will show the waveform shown in Figure 4-1 in terms of the motor rotation direction.

*** Forward rotation or reverse rotation is judged from the feedback pulses of Phase A and Phase B (2-phase pulse that have 90 degrees of phase difference). Therefore, it should be noted that, when connections are wrong, there is possibility for abnormal rotation of the motor.**

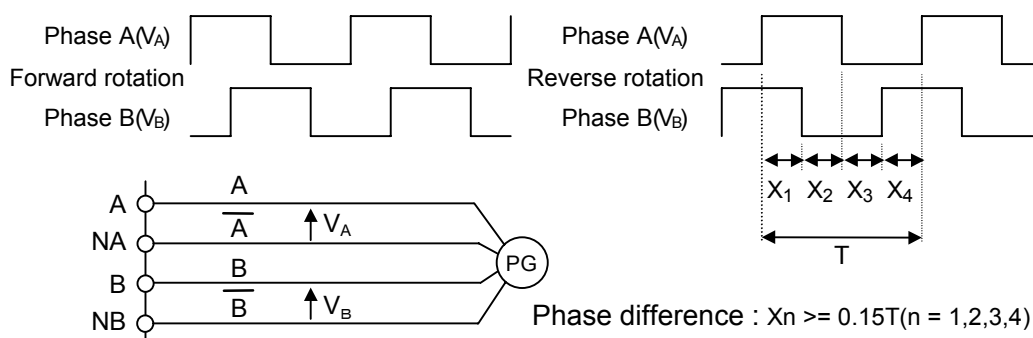

Figure 4-1 Judgement on normal and reverse rotations by the PG feedback of two phases (Phases A and B)

<When PG feedback signal is single phase>

1. For PG feedback signal, connect terminals A and NA.
2. The judgement on forward rotation and reverse rotation is impossible.
Only the speed control mode is applicable.

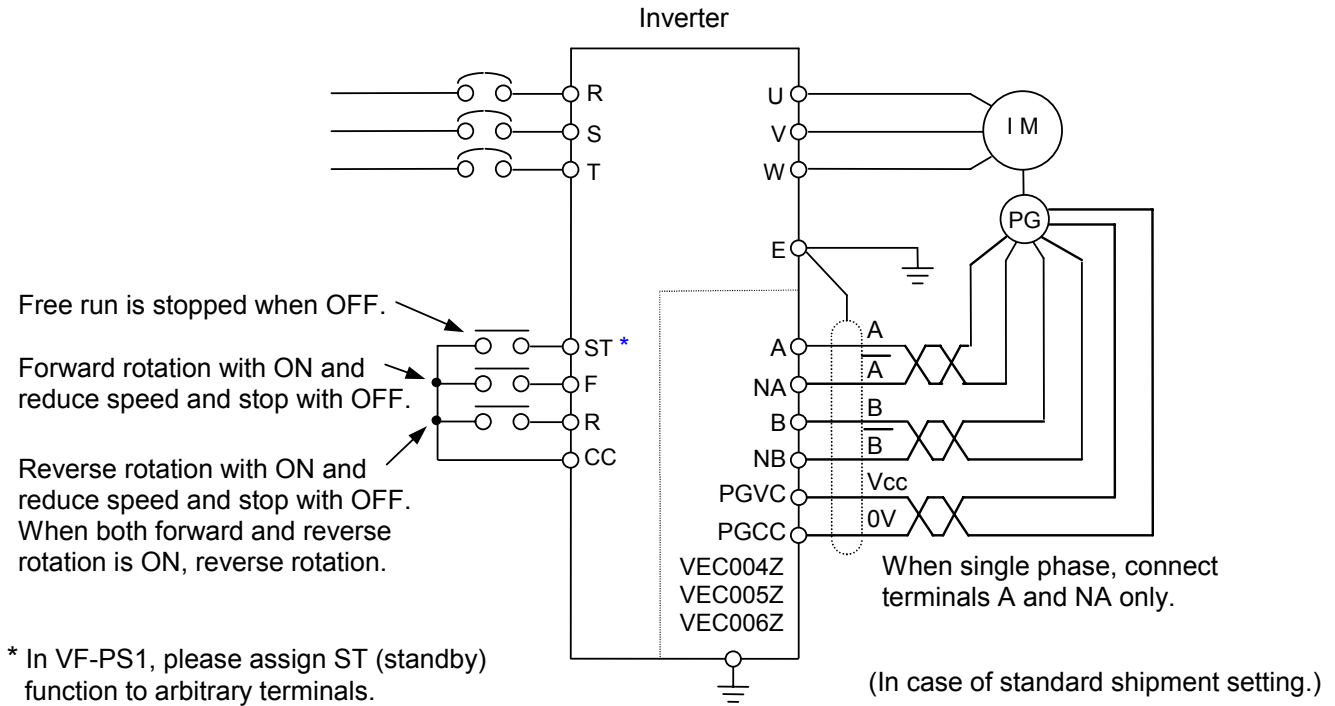

Figure 4-2 Example of complementary encoder connection

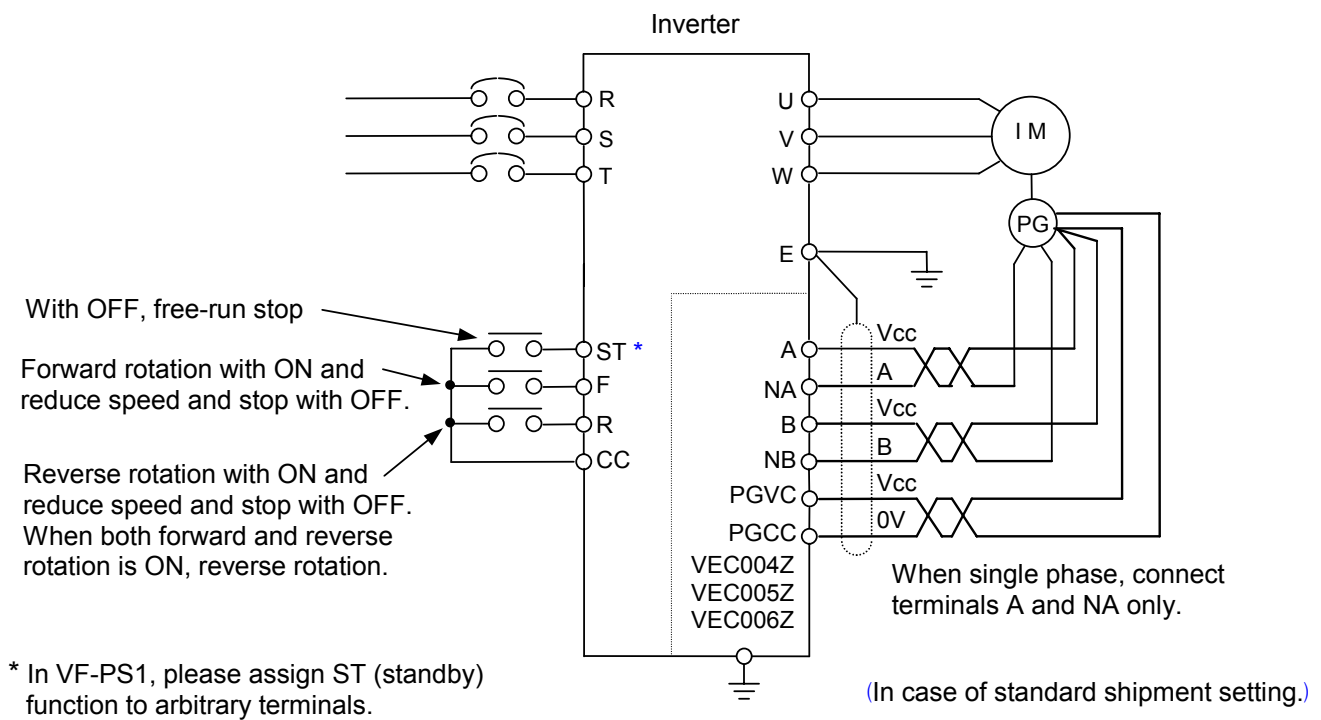

Figure 4-3 Example of open collector encoder connection

* **Caution in case of using open collector encoder connection**

In case using pulse command oscillator and open collector encoder, the rise time of the voltage when the transistor is OFF tends to be longer than the fall time at the time when the transistor is ON. Therefore, if the maximum input frequency becomes higher, the pulse duty cannot maintain the 50±10% specification. Conduct derating on the maximum input frequency so that the pulse duty will be within the following specification range.

<Derating computation formulae of open collector's maximum input pulse frequency >

$$0.8 / (\text{Maximum input frequency} \times A) - \text{Voltage rise time} \geq 3 \times 10^{-6} \dots(1)$$

- A : (single phase input: 2) (two-phase input: 4)
 Voltage rise time : Encoder exclusive pulse rise time + R x C
 Encoder exclusive pulse rise time (s) : Please inquire at the encoder manufacturer.
 R (ohm) (Input resistance) : Internal resistance 1000 (ohm) + external resistance value
 (in case there is external resistance)
 C (F) (Cable static capacity) : Please inquire at the cable manufacturer.

<Example>

- Encoder : IRS350-500 (SUMTAK), 2-phase input
 Encoder pulse rise time: 0.35×10^{-6} (s)
 Cable : ROVV-SB-0.2-5P-10m (Furukawa Electric)
 Static capacity: 120×10^{-12} (F/m) x 10 (m)

From Formulae (1)

$$0.8 / (\text{Maximum input frequency} \times A) - \text{Voltage rise time} \geq 3 \times 10^{-6}$$

$$\text{Voltage rise time} = (0.35 \times 10^{-6}) + 1000 \times (120 \times 10^{-12} \times 10) = 1.55 \times 10^{-6}$$

$$[\text{Maximum input frequency}] \leq 87912 \text{ (Pulse/s) [Single phase input]}$$

$$\leq 43956 \text{ (Pulse/s) [Two-phase input]}$$

■ **The case of VEC007(Line Driver)**

As for the PG feedback signals, Terminal A and NA are connected for Phase A, Terminal B and NB are connected for Phase B.

The polarity of the pulse input signal should be as follows.

Non-inverting input side: A, B

Inverting input side: NA, NB

The signal feedback from the encoder should have the waveform shown in Figure 4-1 in terms of the motor rotation direction. The encoder installation direction and signal wiring should be done accordingly.

*** Forward rotation or reverse rotation is judged from the feedback pulses of Phase A and Phase B (2-phase pulse that have 90 degrees of phase difference). Therefore, it should be noted that, when connections are wrong, there is possibility for abnormal rotation of the motor.**

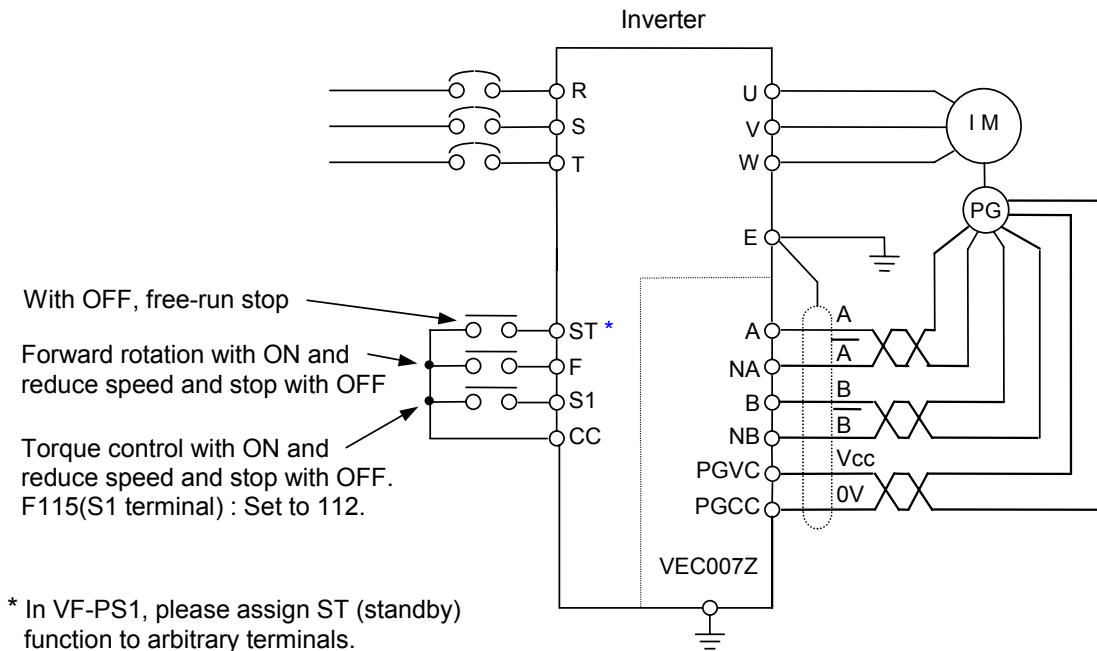

Figure 4-4 Example of wiring for line driver encoder (Speed/Torque switching operation)

*** When using two-phase PG, motor forward and reverse rotation can be judged by PG. When prohibition on reverse rotation is set by the inverter parameter ($F311=1$) and when the motor is rotating to reverse direction due to an external force, the inverter starts with reverse operation in accordance with the motor's direction for a time and the motor will be able to shift to the forward rotation and the smooth startup becomes possible.**

4.1.2. Selection of encoder type

The encoder type should be selected, following the table below.

Encoder Type	Characteristics	Maximum Wiring Length	PG Compatible Board
Complementary	Rated voltage output with emitter/follower combination. High anti-noise characteristics. High-speed response. Long-distance transmission capability. Need to pay attention to waveform irregularity.	100m	VEC004Z VEC005Z VEC006Z
Open Collector	The collector of the transistor is output directly. Low anti-noise characteristics. Low-cost. Need to pay attention to waveform irregularity and distortion.	10m	
Line Driver	IC output for high-speed transmission. High anti-noise characteristics. High-speed response. When transmitting over a long-distance, need to pay attention to power voltage drop.	30m	VEC007Z

4.1.3. Vector control setting parameter

During operation with vector control with sensor, it would be necessary to set the following parameters shown in the table below.

Table 4-1 <Basic parameters>

Title	Function Name	Parameter Setting	Setting at Shipment
Pt	V/F Selection	0: Constant torque characteristics 1: Voltage decrease curve 2: Automatic torque boost 3: Sensorless vector control 1 (speed) 4: Sensorless vector control 2 (speed/torque) * 5: V/f 5-point setting 6: PM control 7: PG feedback vector control 1 (speed) 8: Sensorless vector control 2 (speed/torque) *	0

* These functions are reserved in VF-PS1 (torque control is impossible).

When conducting vector control with sensor (speed/torque control) with this board option, $Pt = 8$ should be set.

For torque control operation, it is necessary to allocate control switching (torque/position) to one of the terminal function selection $F110$ to $F118$ (input terminal function selection 1 to 8) (when $Cnd=0$) or to allocate to communication control switching (when $Cnd=2, 3$ or 4), in addition to the above parameters.

For details of adjustment methods by the speed control command and torque control command, refer to the inverter manual.

Table 4-2 Extended Parameter

Title	Function Name	Parameter Setting	Setting at Shipment
$F375$	Number of PG input pulses	12 - 9999	500
$F376$	Selection of number of PG input phases	1: Single phase input 2: 2-phase input	2
$F377$	PG disconnection detection	0: Deselect 1: Select (with filter) 2: Select (Detection of momentary power failure)	0
$F400$	Auto tuning 1	0: No auto-tuning 1: Initialize motor constant (0 after execution) 2: Continue operation continued after auto-tuning (0 after execution) 3: Auto-tuning by input terminal signal 4: Motor constant auto calculation (0 after execution)	0
$F401$	Slip frequency gain	0 - 100%	70
$F402$	Auto-tuning 2	0: No tuning 1: Self-cooled motor tuning 2: Forced air-cooled motor tuning	0
$F405$	Motor rated capacity (motor name plate)	0.10 - 500.0kW	Depends on type.
$F406$	Motor rated current (motor name plate)	0.1 - 2000A	
$F407$	Motor rated revolutions (motor name plate)	100 - 60000min ⁻¹	
$F410$	Motor constant 1 (torque boost)	0.0 - 30.0%	
$F411$	Motor constant 2 (no load current)	10 - 90%	
$F412$	Motor constant 3 (leak inductance)	0 - 200%	
$F413$	Motor constant 4 (rated slip)	0.1 - 25.0%	

The motor constant parameter ($F405$ to $F413$) requires setting according to the motor used.

For details, refer to the inverter manual.

- (1) The PG number of input pulses ($F375$) is the number of encoder output pulses per one motor rotation.
- (2) For PG input phase number selection ($F376$), set as follows:
 If the encoder pulse is single-phase: 1
 If the encoder pulse is two-phase (Phase A and Phase B signal): 2
When the settings for the above (1) and (2) are wrong, the motor rotation will become abnormal.
- (3) Even though when setting up the PG disconnection detection $F377=2$ (Select (Detection of momentary power failure, hardware detection)), if the Selection of number of PG input phases $F376=1$ (single phase), the detection method is same as $F377=1$ (software detection).

4.1.4. Monitoring method for feedback amount

Motor rotation speed can be monitored.

The motor is equipped with status monitor which is displayed on the panel and analog monitor which used analog output terminals (FM, AM terminals)

Set items (1) and (2) for motor speed monitoring.

- (1) Speed feedback (real-time value) (Unit: Hz/free unit)

The real-time display of motor speed can be made (Monitor display setting: 53).

- (2) Speed feedback (one-second filter) (Unit: Hz/free unit)

The filtered motor speed (feedback value) is displayed. (Monitor display setting: 54).

The monitoring for the above (1) and (2) is possible also in cases except for $Pt=7, B^*$ (PG feedback vector control operation). For example, the monitoring can be used for confirmation of the initial PG feedback amount in open loop (V/F operation and the like).

* This function is reserved in VF-PS1.

<Setting method for status monitoring>

In order to monitor motor rotation speed in condition monitoring, it is necessary to change the setting for extended parameters ($F710$ to $F718$).

Refer to Monitoring Operating Condition section of the inverter manual.

<Setting method for analog monitoring>

In order to monitor motor rotation speed by the analog output terminal, it is necessary to change the setting for basic parameter ($F751, F7$).

Refer to Meter Setting and Calibration section of the inverter manual.

4.1.5. Confirmation of PG's rotational direction

PG's connection in A and B phases and rotational direction of motor can be confirmed as follows.

Set the parameters changed back to the original values following confirming the rotational direction.

- (1) Set parameter $P 7$ (V/F control selected) = 0 (constant torque characteristics).
- (2) Set parameter $F 7 1 1$ (status monitor 1 display selected) = $5 3$ (Signed speed feedback (real-time value)).
- (3) Enter an operating command for positive rotation and command frequency of 1-10Hz to the inverter.
- (4) Confirm the motor be turning in the positive direction.
- (5) Display status monitor 1 by using the status monitor indication of inverter.
- (6) Monitor display, when PG input is determined positive turn 3Hz, " 3.0 " is displayed. When it is determined negative turn 3.0Hz, " $- 3.0$ " is displayed. When determined negative rotation, PG's A/B phase connections and motor wiring are not correct. They must be corrected.

4.1.6. PG disconnection detection function

* Parameter

Title	Function Name	Adjustment Range	Setting at Shipment
$F 3 7 6$	Selection of number of PG input phases	1: Single phase input 2: 2-phase input	2
$F 3 7 7$	PG disconnection detection	0: Deselect 1: Select (with filter) 2: Select (Detection of momentary power failure)	0

* Functions

PG wiring disconnection detection can be confirmed as follows. But the disconnection detection method ($F 3 7 7$) is depended on the using encoder type and the wiring method ($F 3 7 6$). Please refer to the table of "Encoder output format and PGFB board interface" of chapter 3.2 Wiring

4.1.7.Speed abnormality detect function

* Parameter

Title	Function Name	Adjustment Range	Setting at Shipment
F622	Abnormal speed detection time	0.01 - 100.00sec	0.01
F623	Overspeed detection frequency upper band	0.0: Disabled, 0.1 - 30Hz	0.0
F624	Overspeed detection frequency lower band	0.0: Disabled, 0.1 - 30Hz	0.0

* Functions

When operating the speed control with sensor ($P\tau = 7, 8^*$), include during stop condition, the feedback speed is observed. When the timer count of speed error is over the setting time, the system trips by a speed error ($E - 13$).

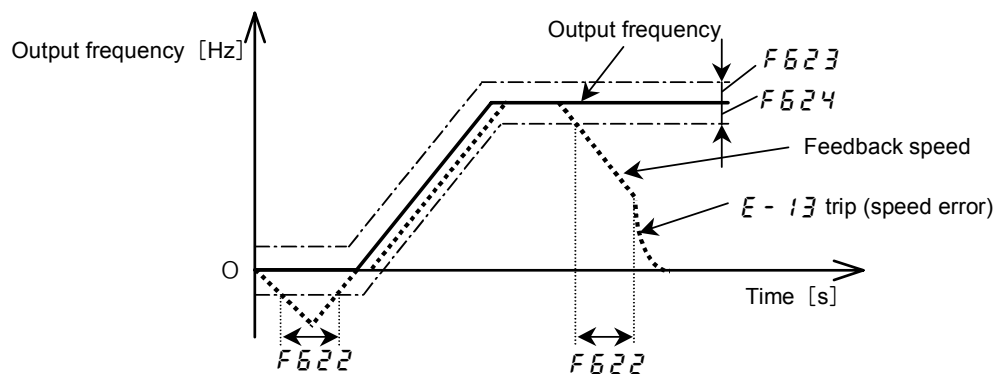

* This function is reserved in VF-PS1.

4.1.8.Accuracy of speed control

The accuracy of speed control with the PG feedback can be obtained by the following formulae.

Accuracy of speed control = Command frequency accuracy + feedback detection accuracy

$$\text{Command frequency accuracy} = \pm \frac{0.01(\text{Hz})}{F_c(\text{Hz})} \times 100 \times \frac{1}{2} \quad [\%]$$

(using digital command)

$$\text{Feedback detection accuracy} = \pm \frac{1}{(F_c/(P/2)) \times PG \times PH \times (1/R_T)} \times 100 \times \frac{1}{2} \quad [\%]$$

F_c : Inverter output frequency

P : Number of motor poles

PG : Number of PG pulses/rotation

PH : Single Phase = 1, Two-Phase = 4

R_T : Refer to below table

Inverter capacity	Speed response R_T
- 2.2kW	300 rad/s
3.7kW - 7.5kW	180 rad/s
11kW -	90 rad/s

4.1.9. Stop position control function (VF-AS1 only)

* Parameter

Title	Function	Adjustment range	Example of setting
<i>P 1</i>	V/f control mode selection	0: Constant torque characteristics 1: Voltage decrease curve 2: Automatic torque boost 3: Sensorless vector control 1 (speed) 4: Sensorless vector control 2 (speed/torque) 5: V/f 5-point setting 6: PM control 7: PG feedback vector control 1 (speed) 8: PG feedback vector control 2 (speed/torque)	0
<i>F 359</i>	PID control switching	0: No PID control 1: Process type PID control (temp./pressure, etc.) operation 2: Speed type PID control (potentiometer, etc.) operation 3: Stop retaining P control	3
<i>F 360</i>	PID control feedback control signal selection	0: Deviation input (no feedback input) 1: VI/II (voltage/current input) 2: RR/S4 (potentiometer/voltage input) 3: RX (voltage input) 4: Optional AI1 (differential current input) 5: Optional AI2 (voltage/current input) 6: PG feedback option	6
<i>F 362</i>	Proportional (P) gain	0.01 - 100.0	0.01
<i>F 375</i>	Number of PG input pulses	12 - 9999 pulses/revolution	500
<i>F 376</i>	Number of PG input phases	1: Single-phase input 2: Two-phase input	2
<i>F 381</i>	Simple positioning completion range	1 - 4000	100

Note: This function will not be performed if *F 240* (starting frequency), *F 241* (operation starting frequency) and *F 243* (stop frequency) are not set at 0Hz, because a 0 Hz command is not issued in that case.

* Functions

This function, which is aimed at retaining the load at standstill at its normal stop position, is used along with the speed sensor vector control function to prevent the position of an elevator at standstill from shifting.

Switching to position control takes place when the load is at a standstill.

The settings of these parameters take effect only in sensor speed control mode.

In speed control mode *7* or *8* specified with the V/f control mode section parameter (*P 1*), simple positioning control is performed upon receipt of a simple positioning signal, with the position at that time used as the reference point (positional deviation: 0).

If the number of PG pulses is smaller than the area of *F 381*, that signal can be output on a terminal block that is set to the 118 as output terminal function.

Ex.) When using the RR/S4 terminal as the simple positioning signal input terminal

Title	Function	Adjustment range	Default setting
F118	Input terminal function selection 8 (RR/S4)	0 - 135	72

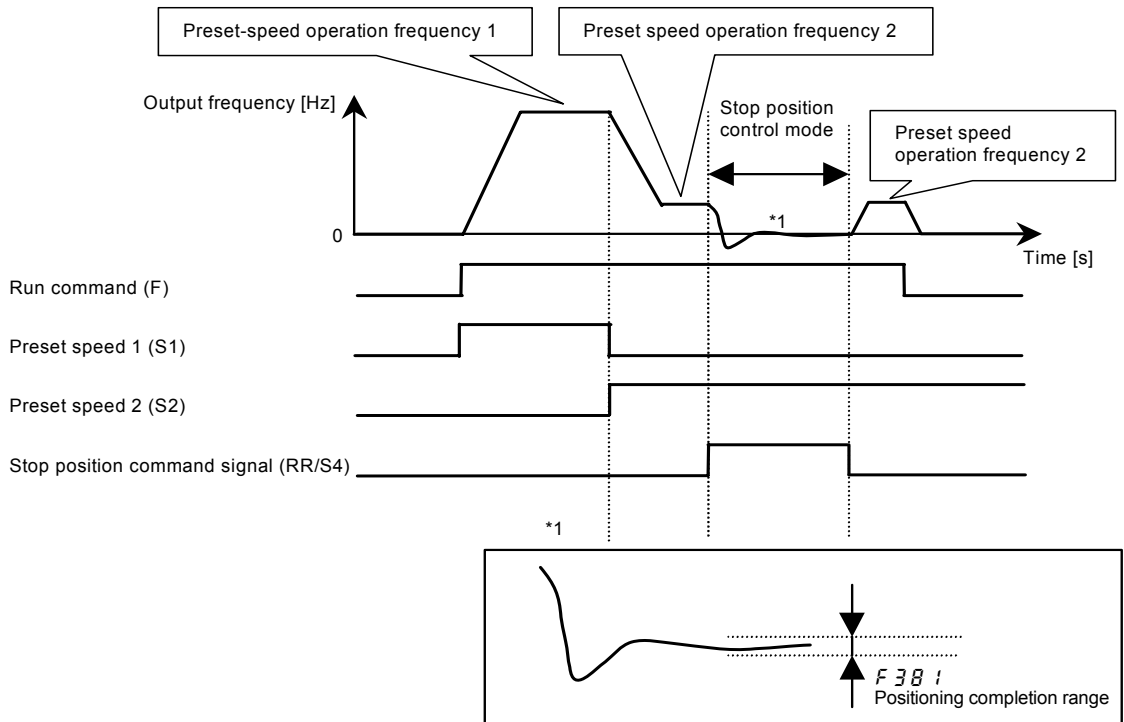

If the stop position control command is entered during high-speed operation, a trip may occur because of overcurrent or overvoltage. To avoid this, do not enter the stop position control command before the motor enters into low-speed operation.

If a trip occurs because of overvoltage when stop position control is performed

If a trip due to overvoltage (OP2 or OP3) occurs when the motor is decelerated by stop position control, reduce the proportional (P) gain with F362 to prolong the deceleration time.

Note: The deceleration time setting (dEL) has no effect during stop position control.

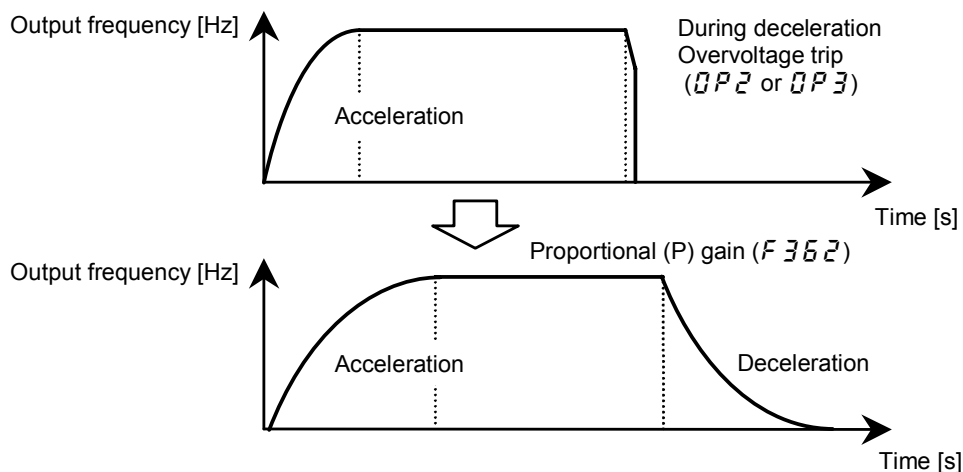

4.2.Pulse input command (speed command selection)

It is possible to input inverter operation frequency command by pulse signals.

This command cannot be used when vector control operation with sensor is effective.

- Inverter output frequency can be controlled in ratio with the pulse output signal from the pulse oscillator.
- By inputting two-phase pulse with 90 degrees phase difference, it is possible to input forward and reverse rotation commands.

4.2.1.Pulse command connection method

Two-phase pulse input command

1. Connect pulse input signal to the point between terminals A and NA on phase A and for between terminals B and NB on phase B
2. The polarity of the pulse input signals should be as follows:
 - + side: A and B
 - side: NA and NB
3. Forward and reverse operation can be judged by the pulse from the phase A and B by using a judgement circuit together with the operational frequency command.
4. The judgement on forward and reverse rotation is made as shown in Figure 4-5.

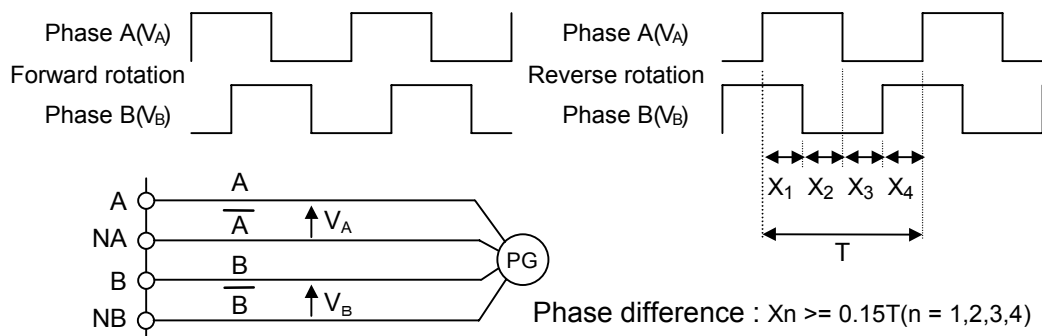

Figure 4-5 Judgement on forward and reverse rotation by the two-phase (Phase A and Phase B) pulse rows

<Caution when using open collector method>

When using open collector method in 4.1.1, the maximum frequency should be derated by referring to the caution item.

The case for single-phase pulse input command

For the pulse input signal, connect between A and NA.

For switching between forward and reverse rotation, with $\overline{CND} = 0$ (Terminal input validation), ON and OFF actions between Terminal F-CC and R-CC are used.

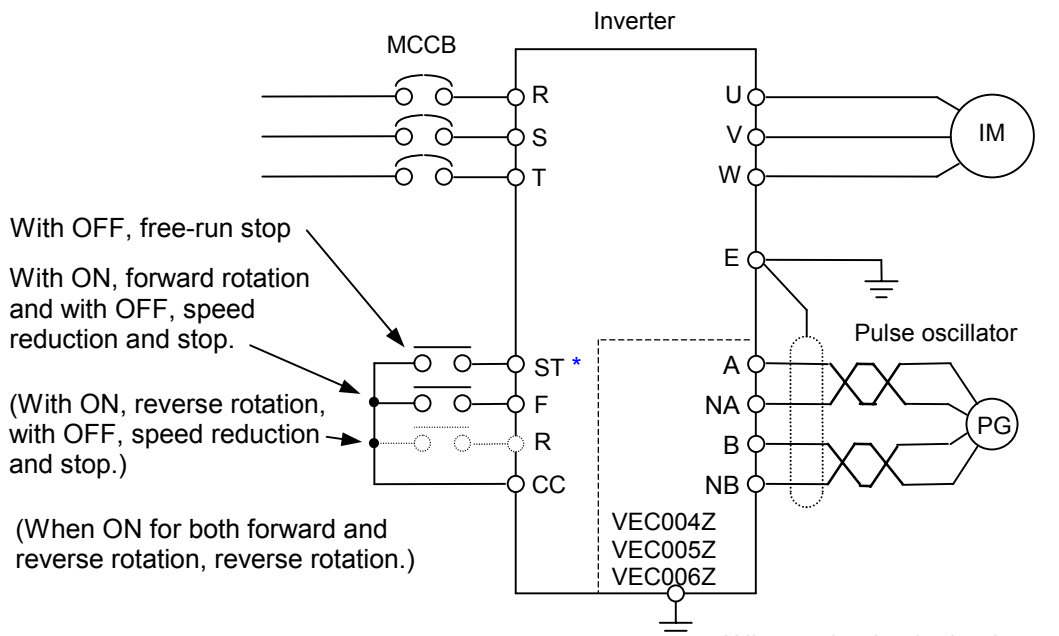

* In VF-PS1, please assign ST (standby) function to arbitrary terminals.

When using in single phase, connect the pulse oscillator between A and NA.

Figure 4-6 Example of connection when operating on pulse row command (speed command)

4.2.2.Pulse input setting parameter

Table 4-3 Necessary Parameter for pulse input setting

Title	Function Name	Adjustment Range	Setting at Shipment
<i>F10d</i>	Speed command selection	12 : High-speed pulse input	2
<i>F200</i>	Frequency priority selection	0 : <i>F10d</i> / <i>F207</i> terminal switching (input terminal function selection 104, 105) 1 : <i>F10d</i> / <i>F207</i> frequency switching (switching with <i>F208</i>)	0
<i>F207</i>	Frequency setting mode selection 2	Same as <i>F10d</i> (1 - 13)	1
<i>F208</i>	Speed command priority switching frequency	0.1 - <i>FH</i> Hz	0.1
<i>F234</i>	RP/high speed pulse input point 1 setting	0 - 100%	0
<i>F235</i>	RP/high speed pulse input point 1 frequency	0.0 - <i>FH</i> Hz	0.0
<i>F236</i>	RP/high speed pulse input point 2 setting	0 - 100%	100
<i>F237</i>	RP/high speed pulse input point 2 frequency	0.0 - <i>FH</i> Hz	80.0
<i>F375</i>	Number of PG input pulses	12 - 9999	500
<i>F376</i>	Selection of number of PG input phases	1 : Single-phase input 2 : Two-phase input	2
<i>F377</i>	PG disconnection detection	0 : Deselect 1 : Select (with filter) 2 : Select (Detection of momentary power failure)	0

* Calculation of the reference frequency

The input pulse frequency is calculated to the percent base data. The calculated percent data is converted to the frequency in accordance with 2 point setting (from *F234* to *F237*). Refer to the below figure. By inputting two-phase pulse with 90 degrees phase difference, it is possible to input forward and reverse rotation commands.

$$\text{Percent base data} = \frac{\text{Input Pulse frequency}}{\text{PG input pulse} \times \text{Maximum frequency}} \times 100 (\%)$$

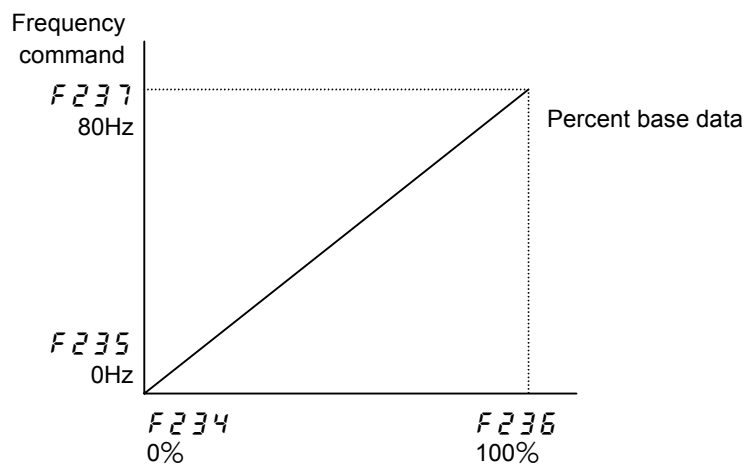

Figure 4-7 Pulse input frequency and frequency command value

*1: The CPU software less than V104 can not detect the direction command of rotation with two-phase input. About the CPU version, please refer to the inverter instruction manual.

4.2.3. Monitoring method of pulse input command

The pulse input command frequency can be monitored.

In order to monitor the pulse input command frequency, set up the monitor display in the frequency command value [Unit: Hz/free unit].

The pulse input command frequency can be confirmed even before the motor is used.

Initial value can be confirmed for the combination testing.

For setting method of the condition monitor, refer to the inverter instruction manual in the “monitoring operation condition” section.

5. External View

External view of PGFB board / Unit external dimension when installing the board. (Unit: mm)

Option board dimension

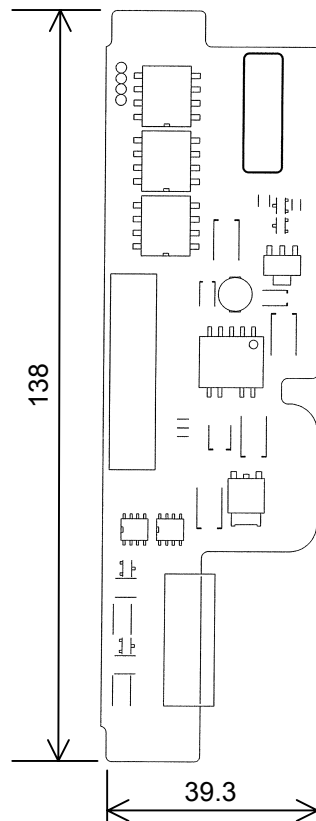

6. Specification

<Environment Specification>

Item	Specification
Use Environment	Indoor, less than 3,000 m from the sea level. No direct sunlight, corrosive or explosive gas, steam, cutting dusts or dusts, grinding solution, and grinding oil.
Ambient Temperature	-10 to + 60°C
Storage Temperature	-25 to +65°C
Relative Humidity	20 to 93 % (No condensation)
Vibration	5.9m/s ² (0.6G) or less (from 10Hz to 55Hz)

<Control Specification>

Type	VEC004Z VEC005Z VEC006Z	VEC007Z
Full-vector operation with sensor	Speed control operation: 150% torque at zero speed Speed control range: 1:1000(1000 ppr PG) Speed accuracy ± 0.02% (50 Hz base digital input) Torque control operation *: Torque control accuracy ± 10% Torque control range: -100 to 100%	
PG Method	Complementary, Open-collector	Line driver
PG Wiring Length	100m (Max.) (Complementary)	30m (Max.)
PG Power Supply	VEC004Z : 12V -160mA VEC005Z : 15V -150mA VEC006Z : 24V -90mA	VEC007Z : 5V -160mA
Max. Pulse Input Frequency	300kHz or less. (In case of two-phase open collector method, derating need to be considered) Pulse duty: 50 ± 10%	
Pulse input voltage	12V DC to 24V DC	Line Driver (LTC486 equivalent)
Recommended Encoder	Manufacturer: SUMTAK Co., Ltd. Type: IRS360 series Supply Voltage: From 10.8V to 26.4V Output Method: complementary output	Manufacturer: SUMTAK Co., Ltd. Type: IRS320 series Supply Voltage: 5V Output Method: line-driver output
Encoder Wiring	Type of Wire: Twisted Pair Shield Cable Conductor Resistance: Conductor Resistance (ohm/m) x cable length (m) x 2 x power consumption (A) < V _D (V) V _D (V): 1.0(V) (VEC004Z, VEC005Z, VEC006Z) 0.3(V) (VEC007Z) Applicable Wire: 0.2 to 0.75mm ² (Power Line) In case of 0.2mm ² cable, maximum of 30m (VEC004Z, VEC005Z, VEC006Z) maximum of 10m (VEC007Z) Recommended Cable : KURAMO Electric: KVC-36SB Furukawa Electric: ROVV-SB	

* Torque control is impossible in VF-PS1.

7.Option Cable

TOSHIBA's sensor cable for VFV3 motor:

Use the sensor cable CAB011 (option) for connection with Toshiba VFV3 motor.

Connection to this option, strip the each wire and wire according to the following table.

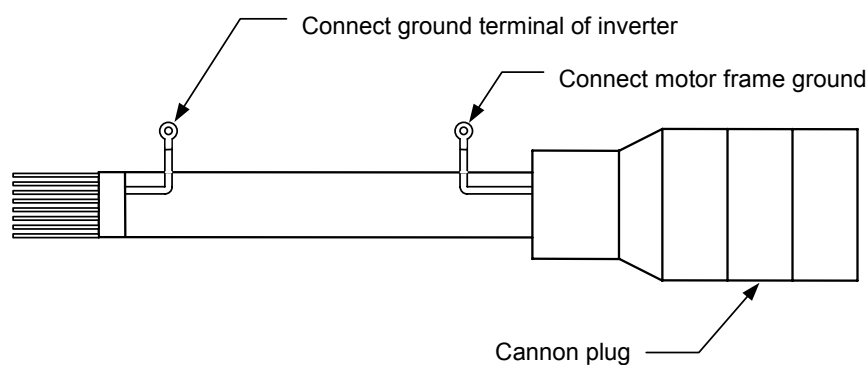

Type-Form	Length (mm)
CAB011-10M	10000±50
CAB011-20M	20000±50
CAB011-30M	30000±50

Table7-1 Processing of VFV3 sensor cable CAB011

Cannon Plug	Wire color*	Signal Name	Description (PG terminal side processing)
A	-	-	-
B	-	-	-
C	-	-	-
D	-	-	-
E	-	-	-
F	-	-	-
G	-	-	-
-	-	-	-
N	-	-	-
H	-	-	-
J	Yellow	NA	Connect to NA terminal.
K	Yellow/White	A	Connect to A terminal.
L	Green	NB	Connect to NB terminal.
M	Green/White	B	Connect to B terminal.
N	Black, Red	COM	Connect to PGCC terminal.
P	Black/White, Red/White	P5	Connect to PGVC terminal.

* Two wires connect to the PGVC and the PGCC of this option.

* There are cases where the wire color may have been changed. Therefore, be sure to confirm on the terminal number of the connector before processing to wire.

* The cut line should be insulated not to contact other wires.

When using CAB010 (option), conduct terminal processing on the CN8 side, referring to Table 7-2.

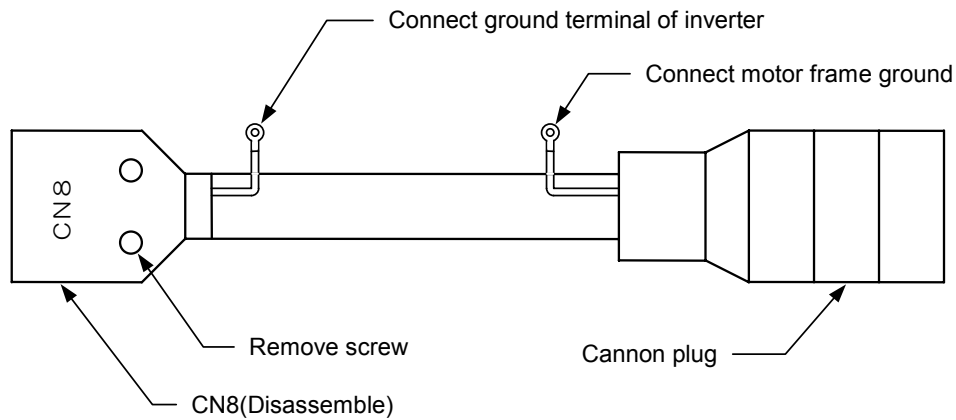

Table7-2 Processing of VFV3 sensor cable

CN8	Cannon Plug	Wire color ^{**}	Signal Name	Description (PG terminal side processing)
1	A	-	-	-
2	B	-	-	-
3	C	-	-	-
4	D	-	-	-
5	E	-	-	-
6	F	-	-	-
7	G	Blue/White	NZ	Not used (Cut)
8	-	-	-	-
9	N	Black	-	Not used (Cut)
10	H	Blue	Z	Not used (Cut)
11	J	Yellow	NA	Connect to NA terminal.
12	K	Yellow/White	A	Connect to A terminal.
13	L	Green	NB	Connect to NB terminal.
14	M	Green/White	B	Connect to B terminal.
15	N	Brown, Red	COM	Connect to PGCC terminal.
16	P	Brown/White, Red/White	P5	Connect to PGVC terminal.

* Two wires connect to the PGVC and the PGCC of this option.

* There are cases where the wire color may have been changed. Therefore, be sure to confirm on the terminal number of the connector before processing to wire.

* The cut line should be insulated not to contact other wires.

8. Warranty

TOSHIBA provides guarantee with the product under the following conditions.

1. If and when a trouble occurs on the board properly installed and handled within one year of delivery, and if the trouble is clearly attributable to defects inherent in our design and manufacture, the product will be repaired free of charge.
2. The warranty covers only the delivered board.
3. Even in the term of the warranty, repair/adjustment service will be changed for the following cases.
 - Fault or damage resulting from misuse, unauthorized modification or repair.
 - Fault or damage resulting from falling down of the product or traffic accident during transportation.
 - Fault or damage originating from fire, salt water/salty breezes, some kind of gas, earthquake, storm or flood, lightning, abnormal supply voltage, other natural disasters.
 - Fault or damage caused by improper use of the inverter as it is used for a purpose out of its original application.
4. If field inspection of the inverter is carried out at the spot of installation, all travelling expenses incurred will be charged. If there is another special warranty contracted for the inverter, the special warranty has priority over this warranty.