

# Product Manual

## Input reactor Motor reactor

for TOSHIBA Inverter



5. April 2008

This instruction manual must be read carefully  
and should be always given to the end user of the device.

Possible subject to modifications without prior notice.



**EUGEN SCHMIDT UND CO**  
**ANTRIEBSTECHNIK**

esco - Eugen Schmidt und Co Getriebe und Antriebselemente GmbH • Biberweg 10 • 53842 Troisdorf - Germany  
Tel. ++49(0)2241/4807-0 • Fax ++49(0)2241/4807-10 • E-Mail: [esco-antriebstechnik@t-online.de](mailto:esco-antriebstechnik@t-online.de) • Internet: [www.esco-antriebstechnik.de](http://www.esco-antriebstechnik.de)

Input reactor / Motor reactor

# Installation details

## Input reactor DWSN

### Connection:

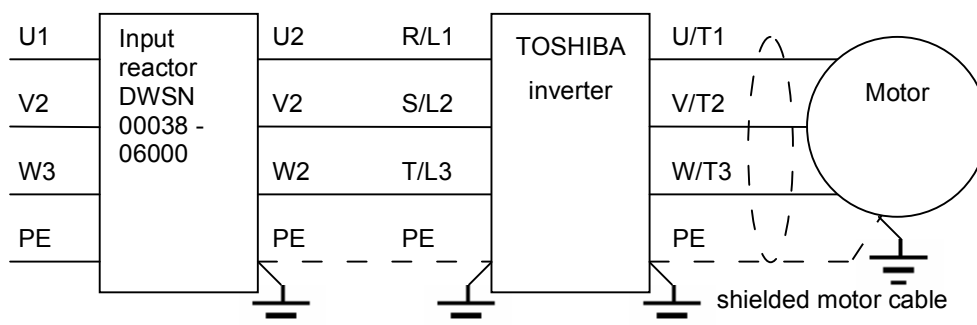

### Please note:

- A shielded input cable between input reactor and inverter is not necessary
- A shielded motor cable is necessary during operations with input reactor
- There is no need to set the inverter for operation with input reactor



**EUGEN SCHMIDT UND CO**  
**ANTRIEBSTECHNIK**

**Index**

1	Single-phase input reactor .....	3
1.1	Technical specifications .....	3
1.2	Outline drawing and dimensions.....	3
2	Three-phase input reactor.....	4
2.1	Technical specifications.....	4
2.2	Outline drawing and dimensions.....	5
3	Three-phase motor reactor.....	6
3.1	Technical specifications.....	6
3.2	Outline drawing and .....	7
4	Attachment: Allocation table inverter to input reactor / motor reactor.....	8

**General**

While operating an inverter, input reactors are recommended, if:

- a compensation unit switches compensation levels.
- the inverter operates with a generator.

The usage of input reactors has also other advantages:

- low-frequency circuit feedbacks are reduced.
- High-energy, transient voltage peaks, caused for example by compensation levels of a compensation arrangement, are damped.
- The devices pre-charged control is not active at temporary voltage drop. Great charging currents can run to the DC-buscapacitor, depending on the grids internal resistance. Input reactors limit these charging currents.
- The current ripple of the DC-bus is reduced, which can increase the DC-bus capacitors life time

Installations with long shielded motor cables (e.g. longer than 50m) can cause high capacitive reflection current because of increased cable capacities. It is possible that the inverter shuts down with the failure indication 'overcurrent'. In this case, it is recommended to use motor reactors.

**1 Single-phase input reactor**

Single-phase air gap reactor (VDE 0550), max. UT 40°C, corrosion protection with complete resin impregnation, insulation class E.  
 Connection orientated by current, on terminal or copper lug.

**1.1 Technical specifications**

Type	Inductance (mH)	Nominal current (A)	Cu-Weight (kg)	Power loss (W)
WSN-00087	3,7	8,6	0,45	10
WSN-00130	1,2	13,0	0,3	13
WSN-00180	0,63	18,0	0,4	16
WSN-00230	1,45	23,0	0,7	21
WSN-00320	0,6	32,0	0,7	28

**1.2 Outline drawing and dimensions**

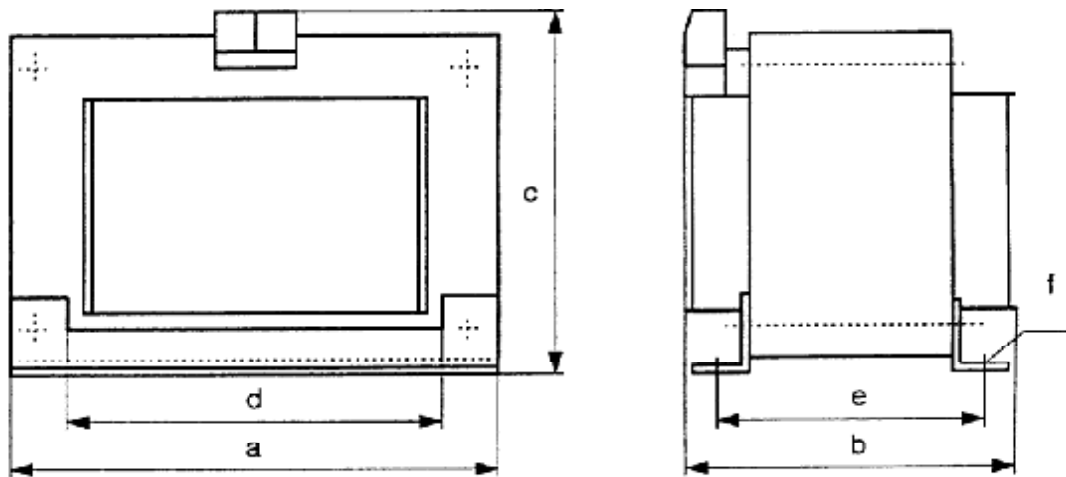

Type	a (mm)	b (mm)	c (mm)	d (mm)	e (mm)	f (mm)	Weight (kg)
WSN-00087	84	108	96	64	61	4,8	2,1
WSN-00130	78	92	106	56	50	4,8	1,6
WSN-00180	84	94	96	64	50	4,8	1,7
WSN-00230	105	102	111	80	62	5,8	3,0
WSN-00320	105	102	111	80	62	5,8	3,0

## Three-phase input reactor

### 2 Three-phase input reactor

Three-phase air gap reactor (VDE 0550), max. UT 40°C, Corrosion protection with complete resin impregnation, insulation class E.

Connection orientated by current, on terminal or copper lug.

#### 2.1 Technical specifications

Type	Inductance (mH)	Nominal current (A)	Cu-Weight (kg)	Power loss (W)
DWSN-00038	3x7,9	3,8	0,8	20
DWSN-00053	3x5,6	5,3	1,0	24
DWSN-00086	3x1,7	8,6	1,5	30
DWSN-00110	3x2,5	11,0	1,5	33
DWSN-00130	3x1,2	13,0	1,0	38
DWSN-00180	3x0,63	18,0	1,8	45
DWSN-00230	3x1,45	23,0	2,5	48
DWSN-00320	3x0,6	32,0	2,5	50
DWSN-00480	3x0,4	48,0	4,3	58
DWSN-00750	3x0,18	75,0	4,5	65
DWSN-00900	3x0,16	110,0	4,8	72
DWSN-01100	3x0,125	110,0	5,5	84
DWSN-01600	3x0,08	160,0	7,0	88
DWSN-01900	3x0,07	190,0	7,4	112
DWSN-02200	3x0,06	220,0	8,5	115
DWSN-02600	3x0,052	260,0	8,5	115
DWSN-03350	3x0,04	326,0	12,0	151
DWSN-04500	3x0,03	440,0	14,0	192
DWSN-06000	3x0,027	600,0	16,0	228

## Three-phase input reactor

### 2.2 Outline drawing and dimensions

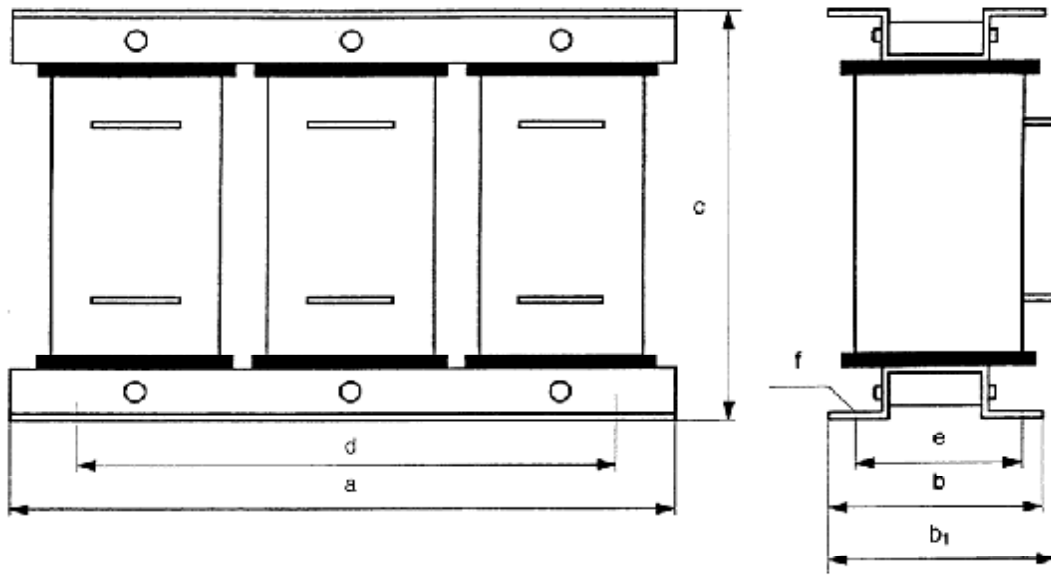

Type	a (mm)	b (mm)	b1 (mm)	c (mm)	d (mm)	e (mm)	f (mm)	Weight (kg)
DWSN-00038	125	71	81	110	100	45	5	2,7
DWSN-00053	125	71	81	110	100	55	5	2,7
DWSN-00086	125	71	81	110	100	45	5	2,7
DWSN-00110	155	77	87	135	130	57	8	4,0
DWSN-00130	125	71	81	110	100	55	5	2,7
DWSN-00180	155	77	87	135	130	57	8	4,0
DWSN-00230	190	91	101	160	170	68	8	8,0
DWSN-00320	190	91	101	160	170	68	8	8,0
DWSN-00480	190	105	115	160	170	80	8	12,0
DWSN-00750	190	105	115	160	170	80	8	12,0
DWSN-00900	190	105	115	160	170	80	8	12,0
DWSN-01100	240	121	135	210	190	96	11	15,5
DWSN-01600	240	141	155	210	190	116	11	21,0
DWSN-01900	240	141	155	210	190	116	11	21,0
DWSN-02200	240	155	170	210	190	130	11	26,0
DWSN-02600	240	155	170	210	190	130	11	26,0
DWSN-03350	300	165	185	270	240	134	11	37,0
DWSN-04500	300	192	215	270	240	161	11	47,0
DWSN-06000	300	192	215	270	240	161	11	47,0

### 3 Three-phase motor reactor

Three-phase air gap reactor (VDE 0550), max. UT 40°C, corrosion protection with complete resin impregnation, insulation class E.

Connection orientated by current, on terminal or copper lug.

#### 3.1 Technical specifications

Type	Inductance (mH)	Nominal current (A)	Cu-Weight (kg)	Power loss (W)
DWSM-00038	3x16,3	3,8	1,5	38
DWSM-00042	3x7,6	4,2	0,8	28
DWSM-00053	3x11,8	5,3	1,6	51
DWSM-00075	3x4,1	7,5	1,0	40
DWSM-00080	3x7,3	8,0	1,8	44
DWSM-00105	3x3,0	10,5	1,4	42
DWSM-00110	3x5,6	11,0	2,5	411
DWSM-00160	3x3,8	16,0	3,0	67
DWSM-00220	3x2,5	22,0	4,5	67
DWSM-00320	3x2,0	32,0	5,5	110
DWSM-00480	3x1,3	48,0	7,0	105
DWSM-00580	3x1,03	58,0	7,3	115
DWSM-00720	3x0,8	72,0	8,5	125
DWSM-00870	3x0,68	87,0	12,0	145
DWSM-01010	3x0,53	101,0	13,0	160
DWSM-01440	3x0,4	144,0	14,0	160
DWSM-01730	3x0,33	173,0	15,0	180
DWSM-02170	3x0,26	217,0	16,0	300
DWSM-02600	3x0,21	260,0	18,0	360
DWSM-03300	3x0,111	330,0	32,0	540
DWSM-04400	3x0,17	440,0	40,0	700
DWSM-05900	3x0,15	590,0	45,0	800
DWSM-06500	3x0,12	650,0	50,0	950

## Three-phase motor reactor

### 3.2 Outline drawing and dimensions

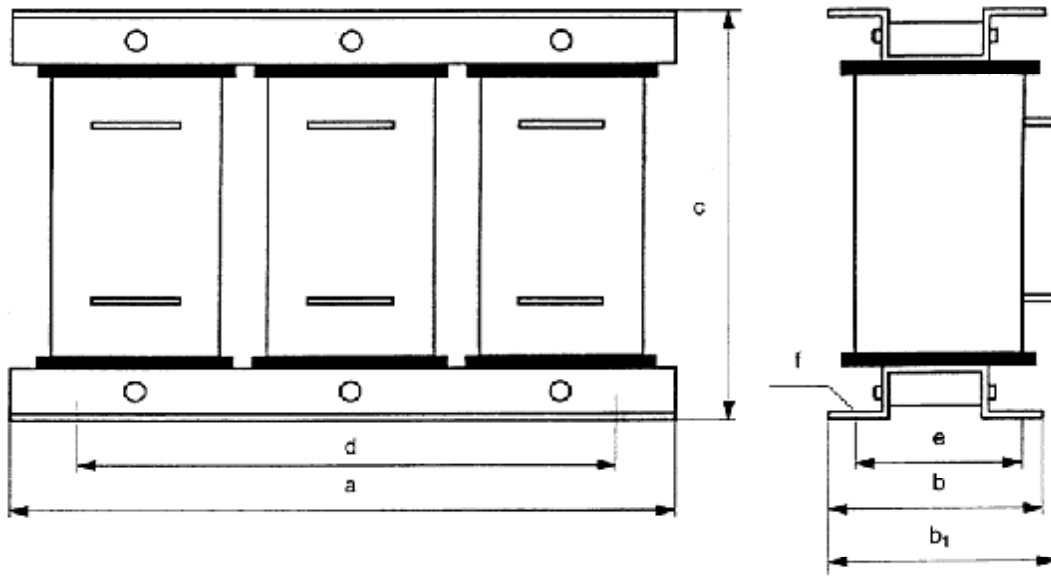

Type	a (mm)	b (mm)	b1 (mm)	c (mm)	d (mm)	e (mm)	f (mm)	Weight (kg)
DWSM-00038	155	77	87	135	130	57	8	4,0
DWSM-00042	125	71	81	110	100	45	5	2,7
DWSM-00053	155	77	87	135	130	57	8	4,0
DWSM-00075	125	71	81	110	100	55	5	2,7
DWSM-00080	155	95	105	135	130	74	8	5,0
DWSM-00105	155	77	87	135	130	57	8	4,0
DWSM-00110	190	91	101	160	170	68	8	8,0
DWSM-00160	190	91	101	160	170	68	8	8,0
DWSM-00220	190	105	115	160	170	80	8	12,0
DWSM-00320	240	121	135	210	190	96	11	15,5
DWSM-00480	240	141	155	210	190	116	11	21,0
DWSM-00580	240	141	155	210	190	116	11	21,0
DWSM-00720	240	155	170	210	190	130	11	26,0
DWSM-00870	300	166	176	270	240	134	11	37,0
DWSM-01010	300	165	185	270	240	134	11	37,0
DWSM-01440	300	192	215	270	240	161	11	47,0
DWSM-01730	300	192	215	270	240	161	11	47,0
DWSM-02170	300	192	215	270	240	161	11	47,0
DWSM-02600	360	163	185	312	310	126	11	52,0
DWSM-03300	420	197	220	365	370	152	11	78,0
DWSM-04400	420	253	275	365	370	212	11	130,0
DWSM-05900	480	250	316	465	430	210	13	160,0
DWSM-06500	480	250	316	465	430	210	13	160,0

Possible subject to modifications without prior notice

**4 Attachment: Allocation table inverter to input reactor / motor reactor**

TOSHIBA Inverter		Power	Nominal current	Input reactor	Motor reactor
VF nC1S-2002PL	VF S11S-2002PL-WP	0,25 KW	1,5 A	WSN00086	DWSM00042
VF nC1S-2004PL	VF S11S-2004PL-WP	0,55 KW	3,3 A	WSN00086	DWSM00042
VF nC1S-2007PL	VF S11S-2007PL-WP	0,75 KW	4,8 A	WSN00130	DWSM00042
VF nC1S-2015PL	VF S11S-2015PL-WP	1,5 KW	7,8 A	WSN00230	DWSM00075
VF nC1S-2022PL	VF S11S-2022PL-WP	2,2 KW	11,0 A	WSN00230	DWSM00105
	VF S11-4004PL-WP	0,37 KW	1,5 A	DWSN00038	DWSM00053
VF A7-4007PLY-EU	VF S11-4007PL-WP	0,75 KW	2,3 A	DWSN00038	DWSM00053
VF A7-4015PLY-EU	VF S11-4015PL-WP	1,5 KW	4,1 A	DWSN00053	DWSM00053
VF A7-4022PLY-EU	VF S11-4022PL-WP	2,2 KW	5,5 A	DWSN00086	DWSM00053
VF A7-4037PLY-EU	VF S11-4037PL-WP	4,0 KW	11,5 A	DWSN00180	DWSM00110
VF A7-4055PLY-EU	VF S11-4055PL-WP	5,5 KW	14,3 A	DWSN00180	DWSM00160
VF A7-4075PLY-EU	VF S11-4075PL-WP	7,5 KW	17,0 A	DWSN00230	DWSM00320
VF A7-4110PLY-EU	VF S11-4110PL-WP	11,0 KW	27,7 A	DWSN00480	DWSM00320
VF A7-4150PLY-EU	VF S11-4150PL-WP	15,0 KW	33,0 A	DWSN00480	DWSM00320
VF A7-4185PY-EU	VF P7-4185PY-EU	18,5 KW	37,0 A	DWSN00480	DWSM00480
VF A7-4220PY-EU	VF P7-4220PY-EU	22 KW	44,0 A	DWSN00480	DWSM00480
VF A7-4300PY-EU	VF P7-4300PY-EU	30 KW	60,0 A	DWSN00750	DWSM00720
VF A7-4370PY-EU	VF P7-4370PY-EU	37 KW	72,0 A	DWSN001100	DWSM00870
VF A7-4450PY-EU	VF P7-4450PY-EU	45 KW	110,0 A	DWSN01100	DWSM01010
VF A7-4550PY-EU	VF P7-4550PY-EU	55 KW	110,0 A	DWSN01600	DWSM01440
VF A7-4750PY-EU	VF P7-4750PY-EU	75 KW	144,0 A	DWSN01600	DWSM01730
	VF P7-4900PY-EU	90 KW	180,0 A	DWSN02200	DWSM02170
VF A7-4110KPY-EU	VF P7-4110KPY-EU	110 KW	210,0 A	DWSN02600	DWSM02170
VF A7-4132KPY-EU	VF P7-4132KPY-EU	132 KW	255,0 A	DWSN03350	DWSM02600
VF A7-4160KPY-EU	VF P7-4160KPY-EU	160 KW	310,0 A	DWSN04500	DWSM03300
	VF P7-4200KPY-EU	200 KW	377,0 A	DWSN04500	DWSM04400
VF A7-4220KPY-EU	VF P7-4220KPY-EU	220 KW	420,0 A	DWSN04500	DWSM04400
VF A7-4280KPY-EU	VF P7-4280KPY-EU	280 KW	540,0 A	DWSN06000	DWSM051100
	VF P7-4315KPY-EU	315 KW	5110,0 A	on request	on request