

VF-S11 RS485 built-in board option

RS4003Z

Instruction Manual

NOTICE

1. Make sure that this instruction manual is delivered to the end user of RS485 built-in option board.
2. Read this manual before installing or operating the RS485 built-in board option.
And keep it in a safe place for reference.

Toshiba Inverter Corporation





© TOSHIBA INVERTER CORPORATION 2003

All Rights Reserved.





Safety precautions

On the inverter and in its instruction manual, important information is contained for preventing injuries to users and damages to assets and for proper use of the device. Read the instruction manual attached to VF-S11 along with this instruction manual for completely understanding the safety precautions and adhere to the contents of these manuals.



Handling in general

 Danger	
 Never Disassemble	<ul style="list-style-type: none"> ▼ Never disassemble, modify or repair the product. Disassembling the product could cause electric shocks, fire or injuries. For repairs, call your agency.
 Prohibited	<ul style="list-style-type: none"> Do not remove this option from VF-S11 when the power is on. It could lead to electric shocks. ▼ Do not put or insert foreign objects such as waste cable, bars, or wires into the product. It could lead to electric shocks or fire. ▼ Do not splash water over the product. It could lead to electric shocks or fire.
 Mandatory	<ul style="list-style-type: none"> ▼ Wiring should be conducted after turning VF-S11 power off. ▼ Turn off the power immediately in case any abnormalities such as smokes, smells or abnormal noise are found. Neglect of these conditions could lead to fire. For repairs, call your agency.

Transportation and installation

 Danger	
 Prohibited	<ul style="list-style-type: none"> ▼ Do not install or operate the inverter if it is damaged or any part is missing from it. Operating a defective inverter could lead to electric shocks or fire. For repairs, call your agency. ▼ Do not put any inflammable material near the product. It could catch fire if the product sparks because of a breakdown and the like. ▼ Do not install the product where it could be splashed with water and the like. It could lead to electric shocks or fire.
 Mandatory	<ul style="list-style-type: none"> ▼ The product must be used under environmental conditions prescribed in this instruction manual. Using the product under conditions not specified by the instruction manual could lead to breakdown. ▼ Install this option in VF-S11 and tighten the screws to the specified torque. Otherwise it could lead to breakdown.
 Warning	<ul style="list-style-type: none"> ▼ Be careful of the option board when you exchange the terminal boards. Otherwise it can cause injury to people.



Wiring

 Danger	
 Mandatory	<p>Turn off input power before wiring.</p> <p>Wait at least ten minutes and check to make sure that the charge lamp (on VF-S11 unit) is no longer lit.</p> <p>Tighten the screws on the terminal board to the specified torque.</p> <p>If the screws are not tightened to the specified torque, it could lead to fire.</p> <p>Electrical construction work must be done by a qualified expert.</p> <p>Connection of input power by someone who does not have that expert knowledge may result in fire or electric shock.</p>

About operation

 Danger	
 Prohibited	<ul style="list-style-type: none"> ▼ Do not wipe the body with a wet cloth. Don't touch the body with your wet hand. It could lead to electric shocks. ▼ Do not pull on the cable It could cause damage or error.

About disposal of the product

 Warning	
 Mandatory	<p>Dispose of the product as an industrial waste.</p> <p>Unless it is disposed of as an industrial waste, it may result in human injury.</p>

Notes on use

NOTES	
	<ul style="list-style-type: none"> ▼ Avoid installation locations that may be subjected to rapid changes in ambient temperature or/and humidity. ▼ Route the transmission cable separate from the inverter input/output power wiring. When disconnecting connection cable, make sure to hold its connector with care not to give unreasonable stress to the cable and the unit. Separate the ground of SHLD terminal on the RS485 built-in board option from those of the inverter and the motor. It could cause malfunction due to noise. Install this unit inside the VF-S11 and secure it with board fixing screws, otherwise it could fall and cause malfunction or breakdown. ▼ Connect an electromagnetic contactor or the like between the inverter and the power source to secure external control of emergency stop of operation.

Table of Contents

1. OVERVIEW.....	5
2. COMMUNICATION SPECIFICATIONS	5
3. NAMES AND FUNCTIONS	6
4. CONNECTION TO THE DEVICE	7
4.1. Installation method	7
4.2. Description of terminals.....	8
4.3. Initial settings	10
4.4. Wiring	11
4.5. RS485 communication cable connection	12
5. VF-S11 COMMUNICATION PARAMETERS.....	13
6. SPECIFICATIONS.....	13
7. WARRANTY	13

1. Overview

Installing this option unit in VF-S11, a network of data communication with multiple inverters connected with a PLC, computer or other devices via RS485, can be configured. Up to 32 units of this option can be connected to the network.

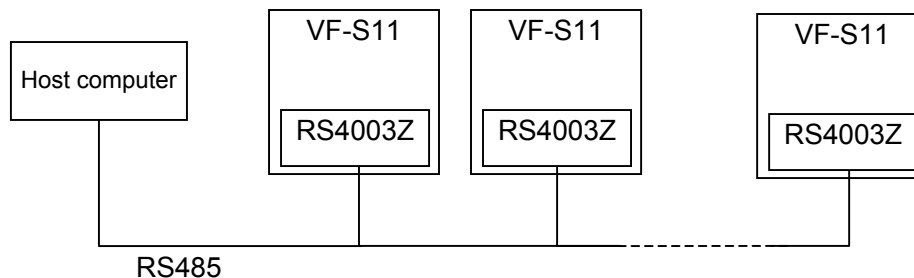

Maximum connectable units: 32
(in a case like the one above, PC is included in the count.)

2. Communication specifications

<RS485 transmission specification>



Item	Specifications
Interface	Conforming to EIA RS485 standard
Configuration	4-wire/2-wire (switch selectable) Bus type (A terminating resistor is required at both ends of the system)
Transmission method	Half-duplex
Maximum communication distance	1,000m *Please refer to Page.10.
Maximum number of connectable option units	32 units (31 units when PC is connected)
Communication line isolation method	No isolation
Terminating resistor	Built-in resistors (110Ω) can be enable
Communication speed	1200/2400/4800/9600/19200 baud rates are selectable (parameter $F800$ is set)
Inverter number	Settable from 1 to 15 using SW5 When SW5 is set to 0, the inverter number set with parameter $F802$ becomes valid.

<Common serial communication>

Common serial option can be used.

(Please use the RS20035-1 as the RS232C communication cable.)

However, when common serial option is used, communication will be forcefully switched to common serial option, thus communication via RS485 is disabled.

 Danger	
 Prohibited	▼ Do not use the RS20035-0 while the RS4003Z is connected to RS485-bus. It could result in wrong operations.

3. Names and functions

The external view of this option and the name of each part are shown below:

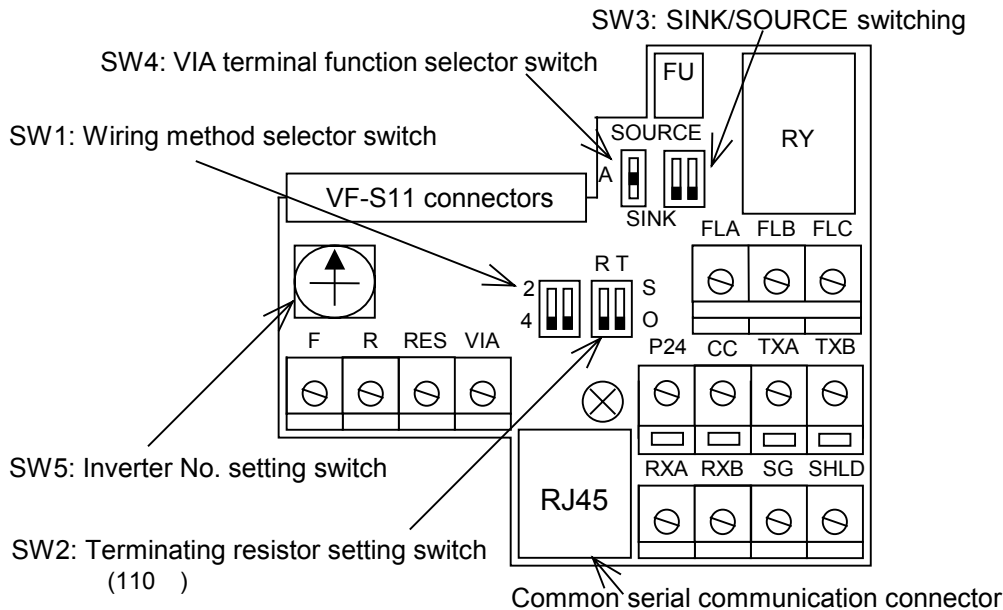

SW1: Wiring method (Set the two switches to the same side.)

2: 2-wire method (RXA and TXA are shorted, and RXB and TXB are shorted.)

4: 4-wire method

SW2: Terminating resistor setting (Connect terminating resistors only to both ends of each system.)

R: Reception side

T: Transmission side

S: Terminating resistor connected (1/2W, 110Ω)

O: Terminating resistor not connected

SW3: SINK/SOURCE selection (Set the two switches on the same side.)

SINK/SOURCE selection of input terminal can be made.

SW4: VIA terminal function selection (VIA terminal function can be selected.)

SOURCE: Logic input (Source), the internal pull-down resistor is inserted between the VIA terminal and the CC terminal.

A : Analog input

SINK : Logic input (Sink), the internal pull-up resistor is inserted between the VIA terminal and the P24 terminal.

* To use this as a logic input, it is necessary to set the parameters (3 or 4 of *F 109*, *F 118*).

SW5: Inverter number setting

Inverter number 1 to 15 can be set. When 0 is set, the setting of parameter *F 802* becomes valid.

Common serial connector

Common serial option can be used but when the common serial function is used (connected), communication via RS485 is disabled.

Terminal blocks (Please refer to Page 8 for the function of each terminal block.)

M3 screw (tightening torque: 0.5 N·m)

Use a flat blade screwdriver with a 0.6 mm thick and 3.5 mm width blade.

4. Connection to the device

4.1. Installation method

Install the RS485 built-in board option to VF-S11 as follows:

- (1) Turn off input power of VF-S11 and wait for at least ten minutes and then check that the CHARGE lamp on VF-S11 is no longer lit.
- (2) Open the VF-S11 front cover, remove the board fixing screw and take out the VF-S11 standard terminal block board.
(Be careful not to lose the board fixing screw when removed since it may be used again.)
- (3) Install the RS485 built-in board option and secure it with the board fixing screw.
(M3 tapping screw tightening torque: 0.7 to 0.8N·m)
- (4) Stick the RS4003Z cabling label on the standard cabling label stuck on the back of the VF-S11 cover.
And stick the RS4003Z name plate near the standard name plate. (Be careful not to cover slits on the VF-S11 main unit.)

* To install or remove the terminal block board, make it slide in or out in parallel with board.

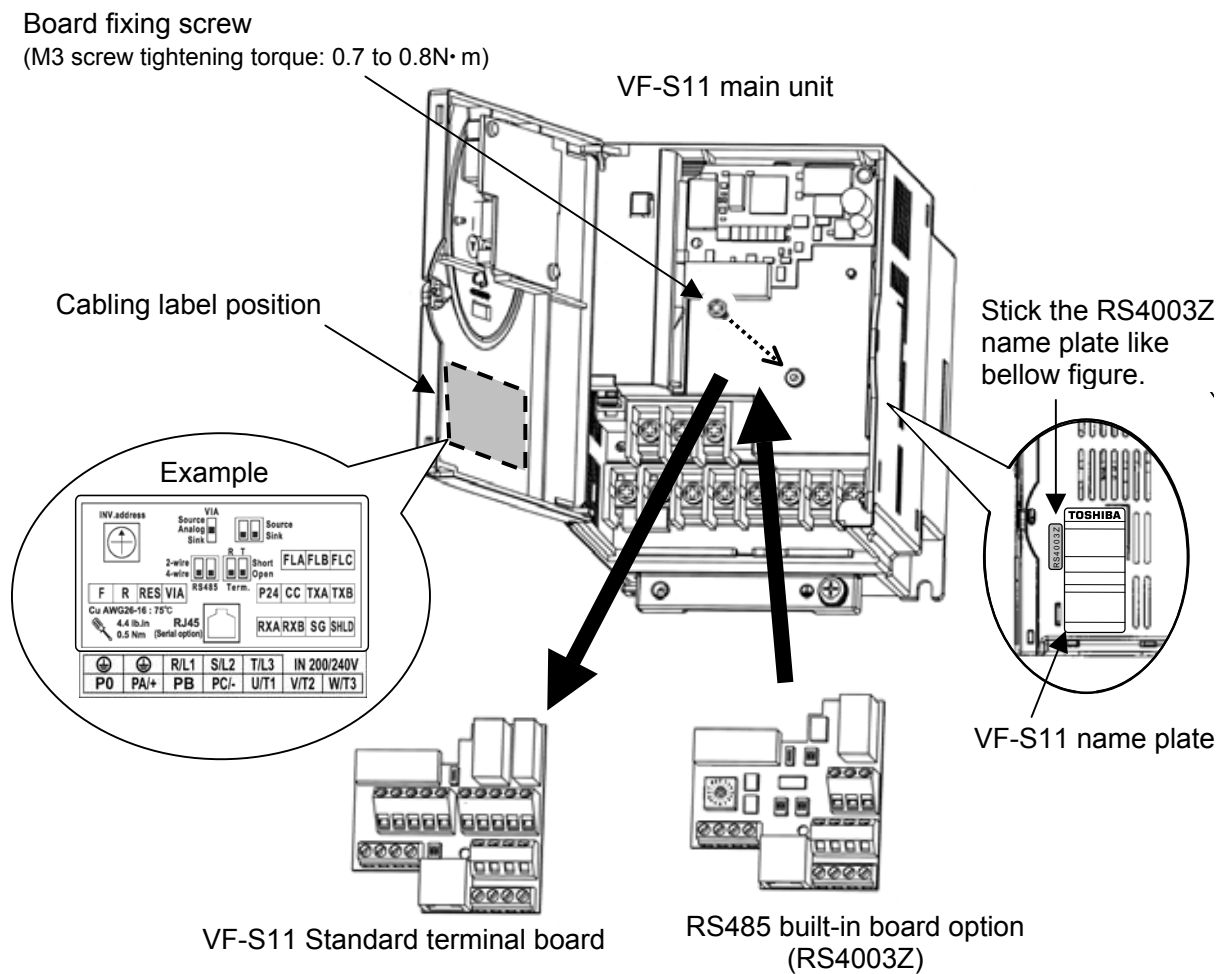



4.2. Description of terminals

<Control circuit terminals specification>

Terminal symbol	I/O type	Function	Electrical specifications
F	Input	Multifunctional programmable contact input. Shorting across F-CC causes forward rotation; opening causes slowdown and stop. (When SINK logic is selected and ST is always ON.)	No voltage contact input 24 V _{DC} , 5mA or less * SINK/SOURCE can be selected with SW3.
R	Input	Multifunctional programmable contact input. Shorting across R-CC causes reverse rotation; opening causes slowdown and stop. (When SINK logic is selected and ST is always ON.)	
RES	Input	Multifunctional programmable contact input. Shorting across RES-CC causes a held reset when the inverter protector function is operating. Note that when the inverter is operating normally, it will not operate even if there is a short across RES-CC. (When SINK logic is selected.)	
VIA	Input	Multifunction programmable analog input. Factory default setting: 0 ~ 60Hz frequency setting with 0 ~ 10 V _{DC} input. In addition, this terminal can be used as a multifunctional contact input using the parameters (<i>F 109</i> and <i>F 118</i>) and SW4 selector switch.	10V _{DC} Internal impedance: 30kΩ
CC	Common to Input/Output	Control circuit's equipotential terminal	
P24	Output	24 V _{DC} power supply output	24V _{DC} -100mA
FLA FLB FLC	Output	Multifunctional programmable relay contact outputs The standard factory setting is set to detect the activation of the inverter protection function. Contact across FLA-FLC is closed and FLB-FLC is opened during protection function operation.	250V _{AC} -1A (cos =1) 30V _{DC} -0.5A 250V _{AC} -0.5A (cos =0.4A)
TXA	RS485	RS485 transmission data (+) terminal	
TXB		RS485 transmission data (-) terminal	
RXA		RS485 reception data (+) terminal	
RXB		RS485 reception data (-) terminal	
SG		RS485 signal ground terminal	
SHLD		RS485 shield terminal. This terminal is not connected to other circuits in this unit. Ground this terminal in a location separated from the ground of power line.	

* For internal circuits, please refer to the VF-S11 Instructions Manual.

 Danger	
 Prohibited	▼ Do not change switch settings while power is on. Changing switches while power is on can damage the product. It could lead to electric shocks, damage and breakdown.

 Mandatory	▼ When setting the VIA function, set the parameter and SW4 after confirming removed motor cables. The motor may suddenly start and that could result in injury.
--	---

4.3. Initial settings

*After reading the previous page for completely understanding the safety, set the initial according to below.

- (1) Turn off the input power of VF-S11, wait for at least 10 minutes and then check that the CHARGE lamp on VF-S11 main unit is unlit.
- (2) Open VF-S11 front cover and set the SINK/SOURCE of contact input with SW3 and SW4. (Check that the two switches of SW3 are on the same side.)
- (3) Set the RS485 wiring method (4-wire/2-wire) using SW1. (Check that the two switches of SW1 are on the same side.) The wiring method of RS485 conversion units connected on the same line shall be set in the same way. (See Page 6.)
- (4) Set the inverter number to SW5 of the RS485 built-in board option. (When the parameter *F002* is used to set this number, set SW5 to zero.) Do not use the same inverter number on the same line. To connect multiple inverters, make sure to set numbers different from each other. (See Page 6.)
- (5) Set a terminating resistor on both ends of the system. This RS485 built-in board option is equipped with terminating resistors. Terminating resistors can be connected by setting the SW2-R (receiving terminal side) and SW2-T (transmission terminal side) to S sides. (See Page 6.)
- (6) Connect a control cable and a RS485 cable to the terminal block. (See Pages 10 and 11.) In this case, be careful not to short-circuit between the adjacent terminals with core wires stuck out.
- (7) Connect the shield of a shielded twisted pair cable to the SHLD terminal of each RS485 built-in board option to form 1-point grounding as a transmission system. At this time, ground the transmission system at a point sufficiently away from the grounded point of power line (host computer side is recommended). (See Page 11.)
- (8) When the switch settings and cable connections are completed, close the front cover and turn on the power of VF-S11.
- (9) Set the parameters of VF-S11. (See Page 12.)
- (10) When the parameters are changed, turn off the power of VF-S11 and then turn on again.

* In this unit, transmission/reception is automatically selected.

Note that using this unit, only half-duplex transmission can be made.

* Observe the following precautions when sending data from host computer to VF-S11:

After return data is received from VF-S11, provide an interval equivalent to 1 data bit or more before sending the next data.

Time equivalent to 1 data bit = $1 / \text{communication speed}$

(Example) "baud rate = 19200 bps; $1b / 19200\text{bps} = 52\mu\text{s}$ "

4.4. Wiring

Observe the following when wiring.

- ◆ Separate the control/communication cables and the main circuit wiring of 20 cm or more without bundling. Wiring them close the one to each other may lead to malfunction due to noise.
- ◆ Use 0.3 to 1.5 mm² solid/stranded wire (AWG 22 to 16) for control cables.

* Interface between programmable controller and inverter

When the operation is to be controlled using a programmable controller which is the open collector output type, if the programmable controller is turned off with the inverter is on, the difference between each control power potential will cause wrong signals to the inverter as shown in below figure. Be sure to provide an interlock so that the programmable controller cannot be turned off when the inverter is on.

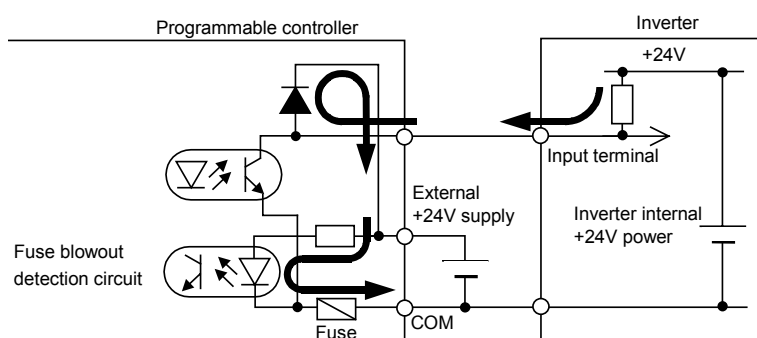

- ◆ Use shielded twisted cables of 0.2 to 1.5 mm² (AWG 24 to 16) for communication cables. Select wire size depending on the transmission distance referring to the table below.

*Use the same type of wires inside the system.

Recommended RS485 transmission cable

Item	Specification		
Transmission cable	Shielded twisted cable		
Connection method	Twisted RXA and RXB wires and twisted TXA and TXB. Twisted RXA (or TXA) and RXB (or TXB) wires for 2-wire system. Note: Connect a terminating resistor at both ends of wires.		
Cable length	Cable type	Cable length	Recommended maker
	CPEV-CU 1.2 mm ϕ (single wire)	1000 m or less	
	KMPEV-SB 0.75 mm ² (twisted wire)	700 m or less	
	KMPEV-SB 0.5 mm ² (twisted wire)	500 m or less	
	GECLS-9004 AWG24 (0.2 mm ²) (single wire)	300 m or less	

- ◆ Remove the sheath of wire about 6 mm (7mm for FLA, FLB and FLC) from the end of wire.
- ◆ Use a flat-headed screwdriver with its blade 0.6 mm in thickness and 3.5 mm in width.
- ◆ Screw tightening torque for the terminal block screws should be 0.5 N·m.

4.5. RS485 communication cable connection

- To connect cables to the terminal block, refer also to the items described in the preceding section.
- Do not connect the shielded wire grounding to the grounding of power line such as the inverter.
 - Separate the transmission cable from the main circuit wiring of 20 cm or more.

Connection example in the case of a 4-wire system

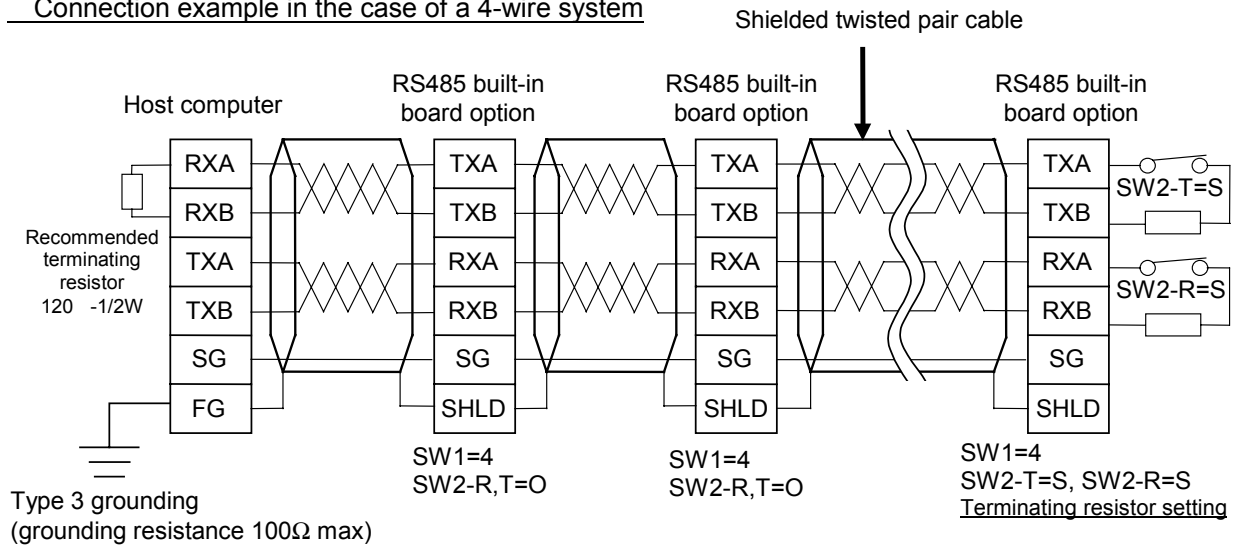

Connection example in the case of a 2-wire system

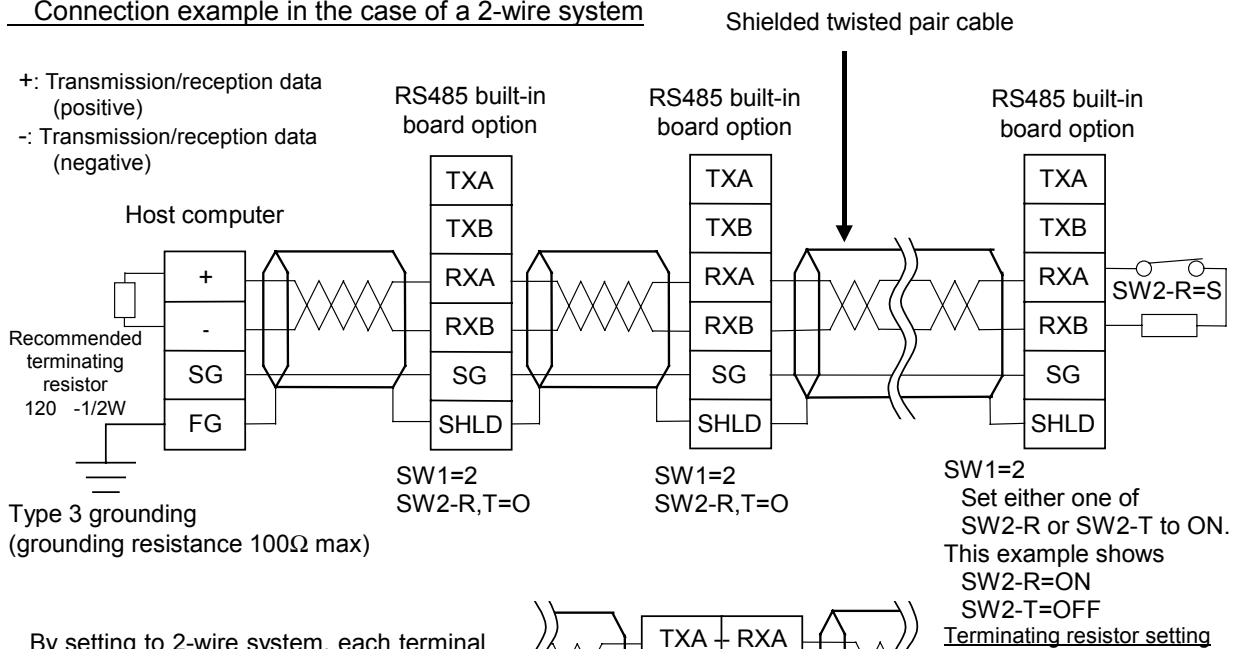

* Since the terminal number on the host computer side differs depending on the model of the computer, read the manual of the computer carefully before connecting it.

5. VF-S11 communication parameters

Function	Parameter	Description
Communication speed	F800	For communication speed on the same line, set the same speed for the inverter and host computer.
Parity	F801	For parity setting on the same line, set the same speed for the inverter and host computer.
Inverter number	F802	This is valid only when SW5 is set to zero. Do not use the same inverter number on the same line. To connect multiple inverters, make sure to set different numbers for inverters and set the inverter number in transmission format.

* For details, please refer to the VF-S11 Instruction Manual and the Communication Function Manual (E6581222).

6. Specifications

Item	Specifications
Part number	RS4003Z
Service environment	Indoors, altitude 1000 m or less, and the following are not allowed: direct sunshine, corrosive and/or explosive gases, steam, powder dust, dust, grinding liquid and grinding oil exposure.
Ambient temperature	Conforms to VF-S11
Storage temperature	From -25°C to +65°C (-13°F to 149°F)
Relative humidity	20 to 93% (without condensation and steam)
Vibration	5.9 m/s ² (0.6G) or less (10 to 55 Hz) (Conforming to JIS C0040)

7. Warranty

Any part of RS485 built-in board option that happens to be defective will be repaired free of charge under the following conditions:

1. If and when a trouble occurs on the option unit properly installed and handled within one year of delivery, and if the trouble is clearly attributable to defects inherent in our design and manufacturing, the product will be repaired free of charge.
2. The warranty covers only the delivered option unit.
3. Even in the term of the warranty, repair service will be charged for the following cases.
 - 1) Fault or damage resulting from misuse, unauthorized modification or repair.
 - 2) Fault or damage resulting from falling down of the product or traffic accident during transportation.
 - 3) Fault or damage originating from fire, salt water/salty breezes, some kind of gas, earthquake, storm or flood, lightning, abnormal supply voltage, or other natural disasters.
 - 4) Fault or damage caused by improper use of this option unit as it is used for a purpose out of its original function.
4. If another special warranty is contracted for this option unit, the special warranty has priority over this warranty.