

TOSVERT VF-FS1 series

Metasys[®] N2 option unit Function Manual

MTS002Z

NOTICE

1. Make sure that this instruction manual is delivered to the end user of Metasys[®] N2 option unit.
2. Read this manual before installing or operating the Metasys[®] N2 option unit. Keep it in a safe place for reference.
3. All information contained in this manual are subject to change without notice. Please confirm the latest information on our web site "www.inverter.co.jp".

Table of Contents

1. INTRODUCTION	2
2. NAMES AND FUNCTIONS OF MAIN PARTS	3
2.1. Outline view.....	3
2.2. Use of RS485 communication port.....	3
2.3. LED indicator.....	4
2.4. Command & Setpoint selection (Local/Remote).....	5
3. PARAMETERS	6
3.1. Communication parameters.....	6
3.2. Communication setting between option board.....	7
3.3. Communication error detection between inverter and option board.....	7
3.4. Selection of the communication protocol (<i>F829</i>).....	7
3.5. Network address (<i>F890</i>).....	7
3.6. Use the serial communication option.....	7
4. FUNCTIONAL PROFILE	8
4.1. Synch Time Command.....	9
4.2. Status Update Request.....	9
4.3. Analog Input Object.....	10
4.3.1. Analog Input Attribute.....	11
4.3.2. Analog Input COS Works.....	12
4.4. Binary Input Object.....	13
4.4.1. Binary Input Attribute.....	13
4.5. Binary Input COS Works.....	14
4.6. Analog Output Object.....	15
4.6.1. Analog Output Attribute.....	15
4.6.2. Analog Output COS Works.....	15
4.7. Binary Output Object.....	16
4.7.1. Binary Output Attribute.....	16
4.7.2. Binary Output COS Works.....	17
4.8. Error Message Format.....	18
4.9. VFFS1 Parameter access.....	19
5. VFFS1 TRIP CODE	20
6. SPECIFICATIONS	21

1. Introduction

Thank you for purchasing the Metasys® N2 option unit (MTS002Z) for VFFS1 series inverter.

Before using Metasys® N2 option unit, carefully read this function manual in order to completely and correctly utilize its excellent performance.

After reading this function manual, please keep it handy for future reference.

For details of its general handling, see an instruction manual attached with the option unit.

- TOSVERT VF-FS1 Instruction Manual.....E6581381
- TOSVERT VF-FS1 Serial Communication Manual.....E6581393
- MTS002Z Instruction ManualE6581454

* Metasys® N2 is a registered trademark of Johnson Controls Inc.

2. Names and functions of main parts

2.1. Outline view

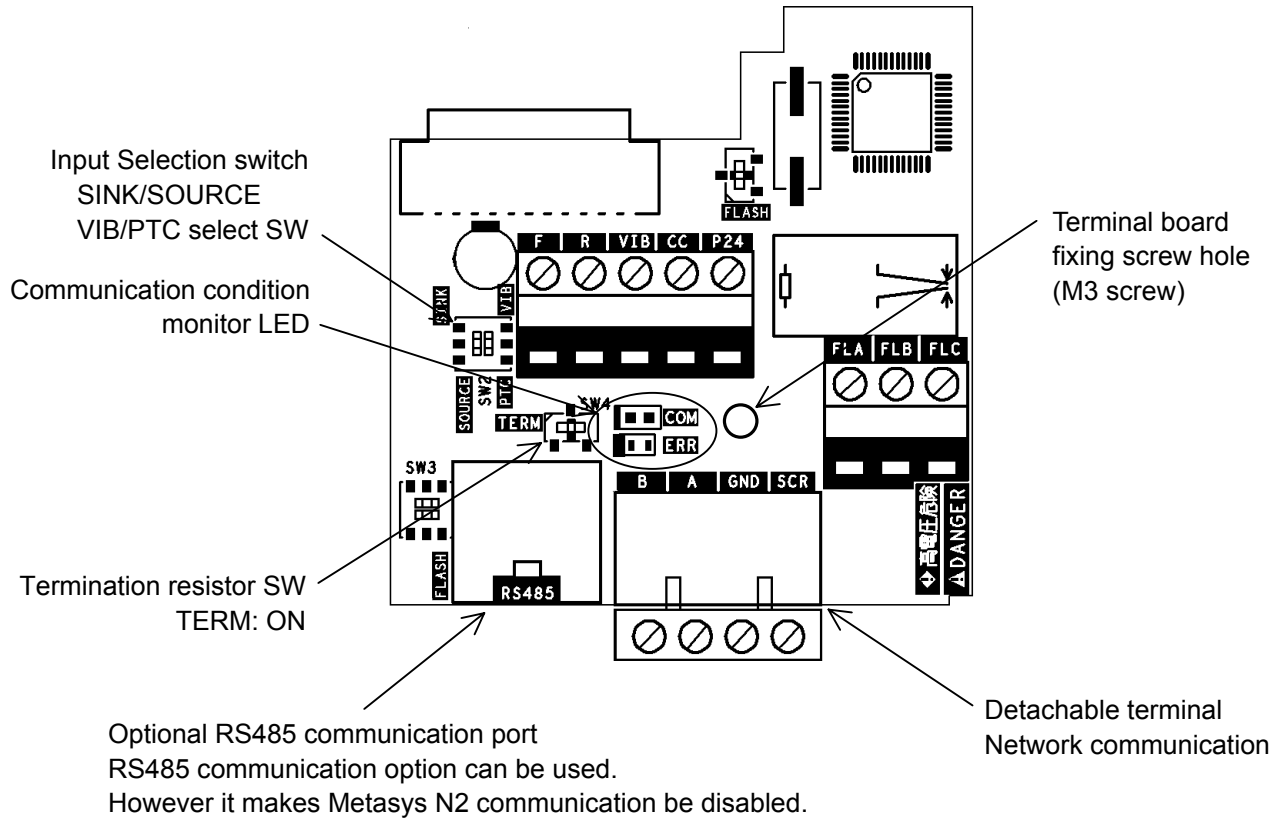

2.2. Use of RS485 communication port

Serial communication (2-wire RS485) option can be used. However, while it is connected, the internal communication line is switched to RS485 then the communication via Metasys[®] N2 network is disabled. In this case, communication error trip time (F803) is also active. Use RS485 serial communication option specified by Toshiba.

2.3. LED indicator

The option has two LEDs. Those function are below table.

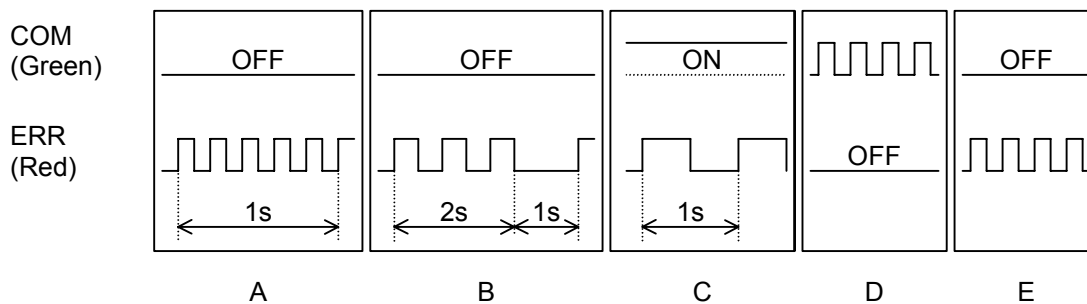

Table 1 LEDs Indication Table

State	LEDs	Comment
A	COM LED: OFF ERR LED: Flashing 5 times in 1 second	MTS002Z failure.
B	COM LED: OFF ERR LED: 3 times in 2 seconds, Off for 1 second	Communication loss detected. Confirm the network condition and connection of the cable.
C	COM LED: ON ERR LED: OFF 0.5s, ON 0.5s	Invalid configuration detected, or a option is connected to RJ45.
D	COM LED: Flashing ERR LED: -	Valid message received for this node
E	COM LED: - ERR LED: Flashing	Invalid message received (any node)

2.4. Command & Setpoint selection (Local/Remote)

Indication to display Local/Remote mode is on the inverter unit (Refer to the inverter instruction manual for details). Metasys® N2 option command and setpoint are activated on Remote mode*.

Inverters have some switches to select the command and setpoint location. Following figure shows the diagram. Refer to the inverter instruction manual for the parameter in detail.

* Be careful that *CNOd* command and *FNOd* setpoint are activated for a short time just after the inverter power turned on. Set *CNOd* and *FNOd* to “network” (“Serial communication” for MTS002Z) to prevent this problem.

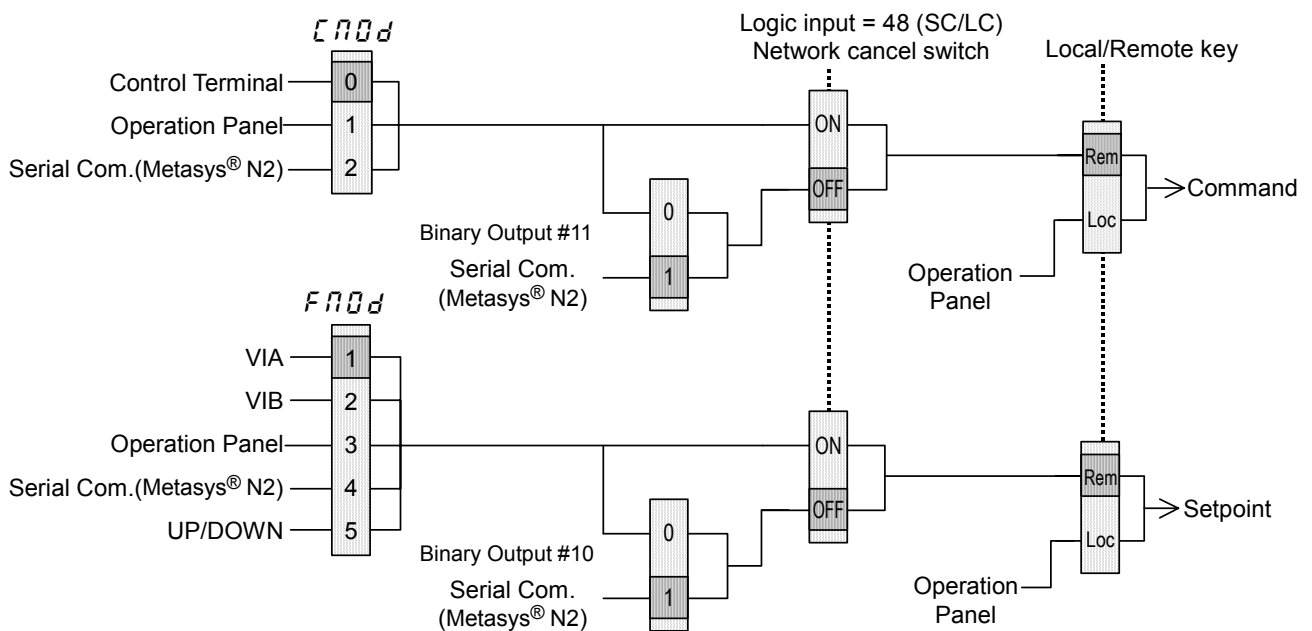

3. Parameters

3.1. Communication parameters

Set up the inverter parameters as follows. To update, reset the power of inverter. If these parameters are not set to correct value, this unit can not work normally.

Table 2 VFFS1 Parameters Table

Title	Function	Description	MTS002Z
<i>F603</i>	Emergency stop selection	0: Coast stop 1: Slowdown stop 2: Emergency DC braking	-
<i>F800</i>	Communication rate	Set "1: 19200bps" (default).	1
<i>F801</i>	Parity	Set "1: Even" (default).	1
<i>F803</i>	Communication error trip time	Set communication time out period.	0
<i>F829</i>	Communication protocol	0: Toshiba inverter protocol 1: Modbus protocol 2: Metasys® N2 protocol 3: APOGEE FLN protocol 4: BACnet protocol	2
<i>F851</i>	Operation at communication error by disconnection	0: Inverter stop, communication command, frequency mode open (by <i>ENOD</i> , <i>FNOD</i>) 1: None (continued operation) 2: Deceleration stop 3: Coast stop 4: Network error (<i>ERRB</i> trip)	-

Title	Function	Description	MTS002Z
<i>F890</i>	Address	Set node address	0 - 255
<i>F892</i>	Network Time-Out	0: No action Unit 0.1 sec, Setting range: 1 - 65535	-
<i>F897</i>	Version	The software version of MTS002Z	(100)

* When *FNOD* or *ENOD* is set to "Serial Communication", VFFS1 drives without FRCMDMOD (Binary Output Object - 11) or RSCMDMOD (Binary Output Object - 10) at each Objects.

Warning



- ▼ Set up "Communication error trip function (*F803*, see the inverter instruction manual for details)" to stop the inverter when this option unit is deactivated by an unusual event such as tripping, an operating error, power outage, failure, etc. Deactivated option unit may cause an accident, if the "Communication error trip function" is not properly set up.

3.2. Communication setting between option board

Do not change communication rate (*F800*) and parity (*F801*) from shipment setting. If change the setting, the option board does not work properly.

3.3. Communication error detection between inverter and option board

Set the communication loss action time to *F803* between the inverter and the option board. And the network communication loss action time to *F892*. The network loss action function starts from receiving the properly frame message. The action of the network communication loss is set by *F851*.

When set the communication loss action time *F803* and connect the option to the RJ45 connector, the communication between the inverter and the option is disabled, so the communication loss may be detected. The action of the inverter and the option board communication loss is set by *F603*.

3.4. Selection of the communication protocol (*F829*)

Set the communication protocol *F829* to "2: Metasys[®] N2 protocol". The communication protocol of RJ45 is set to MODBUS, so when communicate with PC, use MODBUS protocol.

3.5. Network address (*F890*)

Set the network address of this node. Do not set same address number in the Metasys[®] N2 [network](#). If set wrong number, the option board does not work properly.

3.6. Use the serial communication option

Serial communication (2-wire RS485) option can be used. However, while it is connected, the internal communication line is switched to RS485 then the communication via Metasys[®] N2 network is disabled. In this case, communication error trip time (*F803*) is also active.

Use RS485 serial communication option specified by Toshiba.

4. Functional profile

MTS002Z supports the following commands and objects.

Table 3 Analog Input Objects Table

Command/ Sub command/ Region			Function	Support	Note	
0	0	-	Synch Time Command	✓		
	1	-	Read Memory Command	No support	"N01" response	
	4	-	Poll Without Ack Message	✓		
	5	-	Poll With Ack Message	✓		
	8	-	Warm Start	No support	"N01" response	
	9	-	Status Update Request	✓		
1 { Read }	1	-	Read Analog Input Command	✓		
	2	-	Read Binary Input Command	✓		
	3	-	Read Analog Output Command	✓		
	4	-	Read Binary Output Command	✓		
	5	-	Read Internal Parameter Command (Float)	No support	"N01" response	
	6	-	Read Internal Parameter Command (Integer)	No support	"N01" response	
	7	-	Read Internal Parameter Command (Byte)	No support	"N01" response	
2 { Write }	1	-	Write Analog Input Command	✓		
	2	-	Write Binary Input Command	✓		
	3	-	Write Analog Output Command	✓		
	4	-	Write Binary Output Command	✓		
	5	-	Write Internal Parameter Command (Float)	No support	"N01" response	
	6	-	Write Internal Parameter Command (Integer)	No support	"N01" response	
	7	-	Write Internal Parameter Command (Byte)	No support	"N01" response	
7 { Override }	2	01	Override Analog Input Command	No support	"N01" response	
		02	Override Binary Input Command	No support	"N01" response	
		03	Override Analog Output Command	✓		
		04	Override Binary Output Command	✓		
		05	Override Internal Parameter Command (Float)	No support	"N01" response	
		06	Override Internal Parameter Command (Integer)	No support	"N01" response	
		07	Override Internal Parameter Command (Byte)	No support	"N01" response	
7	3 { Override Release }	01	Override Analog Input Release Request	No support	"N01" response	
		02	Override Binary Input Release Request	No support	"N01" response	
		03	Override Analog Output Release Request	✓		
		04	Override Binary Output Release Request	✓		
		05	Override Internal Parameter Release Request	No support	"N01" response	
		06	Override Internal Parameter Release Request	No support	"N01" response	
		07	Override Internal Parameter Release Request	No support	"N01" response	
	7 { Write Attributes }	7	01	Write Analog Input Attributes Request	✓	
			02	Write Binary Input Attributes Request	✓	
			03	Write Analog Output Attributes Request	✓	
			04	Write Binary Output Attributes Request	✓	
	8 { Read Attributes }	8	01	Read Analog Input Attributes Request	✓	
			02	Read Binary Input Attributes Request	✓	
			03	Read Analog Output Attributes Request	✓	
			04	Read Binary Output Attributes Request	✓	
	8	0 - 4	-	Upload Request (data base)	No support	"N01" response
9	0 - 4	-	Download Request (data base)	No support	"N01" response	
F	-	-	Identify Device Type Command	✓		

4.1. Synch Time Command

MTS002Z responds "A" to Synch Time Command.

A normal response to Synch Time Command.

CHAR1 Start of message..... A
CHAR1 End of message (CR)

4.2. Status Update Request

The form and the version information of the MTS002Z connected inverter are returned.

Response example)

CHAR1 Start of message..... A
CHAR16 Model number..... VFFS1-2007PM
CHAR4 Days in service..... 0000
CHAR4 Device status 0108
CHAR2 Checksum 02
CHAR1 End of message (CR)

4.3. Analog Input Object

Analog Input Object is used for the output frequency of VFFS1, and the monitor of analog input terminal. COS (Change Of State) alarm and warning functions are also enabled.

Overriding of analog input is not supported.

Table 4 Analog Input Objects Table

Object number	Object name	Contents	Units
0	OUTPUTSPEED	Output speed	min ⁻¹
1	OUTPUTFREQ	Output frequency	Hz
2	DCBUSVOLT	DC bus voltage	V
3	OUTPUTVOLT	Motor voltage	V
4	CURRENT	Motor current	A
5	TORQUE	Motor Torque	%
6	POWER	Motor Power	%
7	DRIVETEMP	Drive Thermal State	%
8	KWH	Input Energy counter	kWh
9	RUNTIME	Operating time	h
10	LASTFLT	Error code **	-
11	PREVFLT1	Previous fault 1 **	-
12	PREVFLT2	Previous fault 2 **	-
13	MBOXVALUEREAD	Refer to section 4.9.	-
14 *	-	-	-
15 *	-	-	-
16	AI2ACT	Analog input value 2 (VIB)	-

* Object number 14, 15 are reserved (The response is "A").

** Refer to section 5 about the trip code of VFFS1.

4.3.1. Analog Input Attribute

Table 5 Analog Input Attribute Table

Attribute	Type	Contents
1	Byte	Object Configuration
		Bit 0 = COS_enabled (1) Bit 1 = unused Bit 2 = unused Bit 3 = alarm_enabled (1) Bit 4 = warning_enabled (1) Bit 5 = unused Bit 6 = unused Bit 7 = unused
2	Byte	Object Status
		Bit 0 = reliable (0) / unreliable (1) Bit 1 = override active (1) Bit 2 = out of range - high (1) Bit 3 = out of range - low (1) Bit 4 = COS status Bit 5 = COS status Bit 6 = COS status where Bits 4,5,6 are: 000 = normal 001 = trouble (JCI use only) 010 = not available 011 = low warning 100 = low alarm 101 = high warning 110 = high alarm Bit 7 = unused
3	Float	Analog Input Value
4	Float	Linear Ranging Parameter 1 (JCI use only)
5	Float	Linear Ranging Parameter 2 (JCI use only)
6	Float	Linear Ranging Parameter 3 (JCI use only)
7	Float	Linear Ranging Parameter 4 (JCI use only)
8	Float	Low Alarm Limit
9	Float	Low Warning Limit
10	Float	High Warning Limit
11	Float	High Alarm Limit
12	Float	Differential
13	Integer	Filter Weight (JCI use only)
14	Float	AI_Offset (JCI use only)

* Added shading functions are not supported (The response is "N10").

4.3.2. Analog Input COS Works

Analog Input points use 3 bits in the object configuration to determine how COS is reported. First, no COS is reported when the COS_enabled bit is zero. If the COS_enabled bit is set then COS will be reported whenever the object status changes. The alarm_enabled and warning_enabled bit of the object configuration allow the supervisory system to control the types of COS reported. If the alarm_enabled bit is zero, then the COS status of the object status would not have a low alarm or high alarm condition. If the warning_enabled bit is zero, then the COS status of the object status would not have a low warning or high warning condition. If both bits are zero, then the COS status would be normal.

COS works of MTS002Z is following.

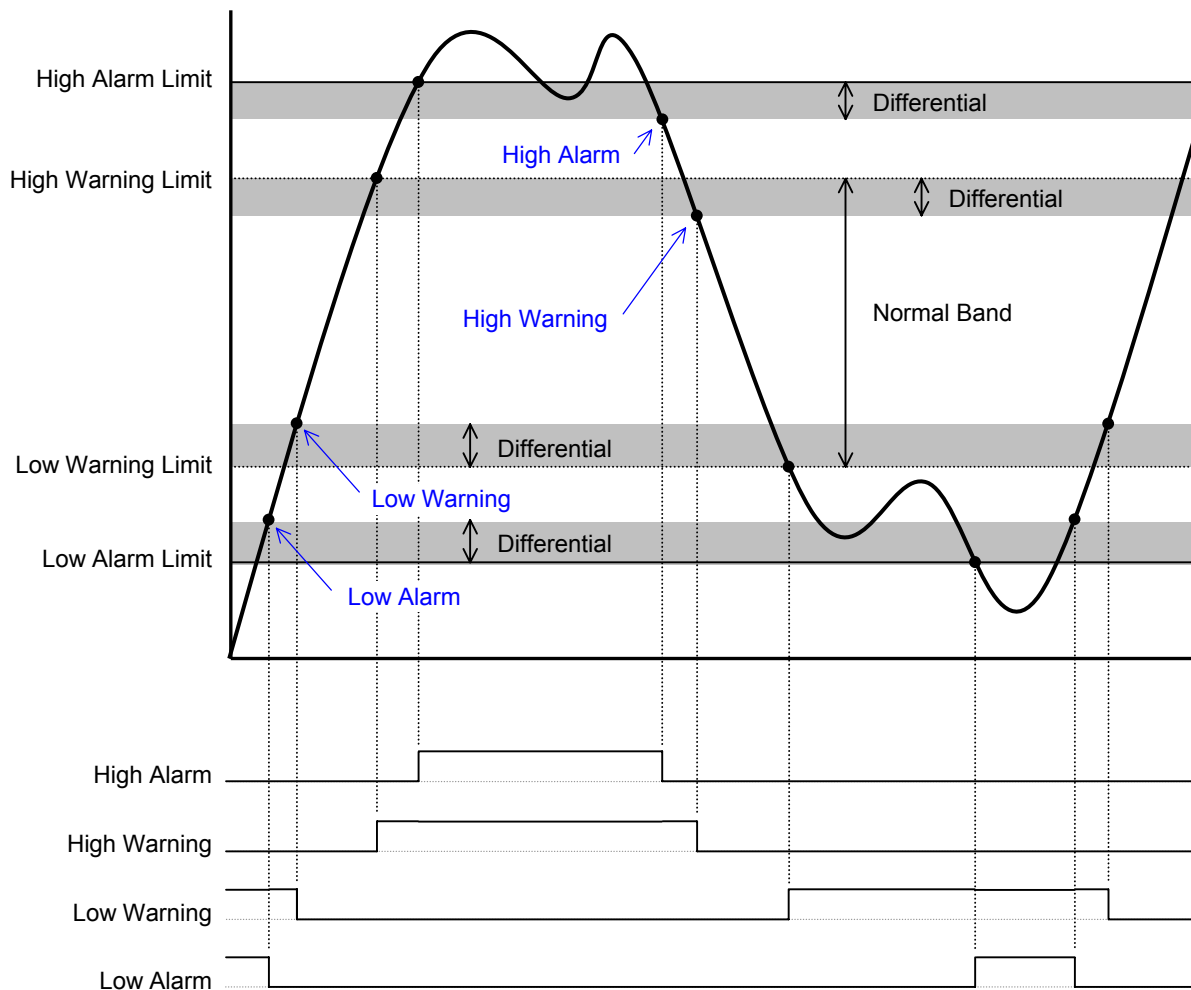

* Status priority is given to "alarm" when both "alarm" and "warning" are enabled.

Status	ON	OFF
High Alarm	Analog Input Value > High Alarm limit	Analog Input Value < High Alarm limit - Differential
High Warning	Analog Input Value > High Warning limit	Analog Input Value < High Warning limit - Differential
Low Warning	Analog Input Value < Low Warning limit	Analog Input Value > Low Warning limit + Differential
Low Alarm	Analog Input Value < Low Alarm limit	Analog Input Value > Low Alarm limit + Differential

4.4. Binary Input Object

Binary Input Object is used for the status of VFFS1, and the monitor of a logic input terminal. COS alarm and warning functions are also enabled.

Overriding of analog inputs is not supported.

Table 6 Binary Input Objects Table

Object number	Object name	VFFS1	Contents
0	RO1ACT	FL (TB)	0 = OFF, 1= ON
1	RO2ACT	RY (TB)	0 = OFF, 1= ON
2	DI1ACT	F (TB)	0 = OFF, 1= ON
3	DI2ACT	R (TB)	0 = OFF, 1= ON
4 *	-	-	-
5	RUNSTOP	-	0 = Stop, 1= Run
6	FWDREV	-	0 = Fwd, 1= Rev
7	FAULT	-	1 = Tripped
8	HANDAUTO	-	1 = Serial communication
9	MAINTREQ	-	1 = Cumulative operation alarming
10	DRIVEREADY	-	0 = Start-up, 1 = Standby
11	ATSETPOINT	-	1 = Achieved

* Reserved (The response is "A").

4.4.1. Binary Input Attribute

Table 7 Binary Input Attribute Table

Attribute	Type	Contents
1	Byte	Object Configuration Bit 0 = COS_enabled (1) Bit 1 = normal state Bit 2 = unused Bit 3 = alarm_enabled (1) Bit 4 = unused Bit 5 = unused Bit 6 = unused Bit 7 = unused
2	Byte	Object Status Bit 0 = reliable (0) / unreliable (1) Bit 1 = override active (1) Bit 2 = unused Bit 3 = unused Bit 4 = normal (0) / alarm (1) Bit 5 = normal (0) / trouble (1) (JCI use only) Bit 6 = current state Bit 7 = unused
3	Integer	Debouncing Value in Msec (1-65535) (JCI use only)
4	Integer32	Accumulator value (JCI use only)

* Added shading functions are not supported (The response is "N10").

4.5. Binary Input COS Works

First, no COS is reported when the COS_enabled bit is zero. If the COS_enabled bit is set then COS will be reported whenever the object status changes.

The alarm_enabled bit of the of the object configuration allow the supervisory system to control the types of COS reported. If the alarm_enabled bit is zero, then the COS status of the object status would never have the normal/alarm bit set to alarm.

This bit is set to alarm when the normal state of the object configuration does not match the current state of the object status.

4.6. Analog Output Object

Analog Output is used for the speed reference of VFFS1 etc. COS alarm and warning functions are also enabled.

Overriding of analog outputs will be accepted and acknowledged with the active override flag set. Upon release of the override command, the analog output point will reset the active override flag, retain the override value, and not return to its pre-override value.

Table 8 Analog Output Objects Table

Object number	Object name	Contents	Units
0	INPUTREF	Speed reference from Bus *	%
1	ACCELTIME	Acceleration time	0.1s
2	DECELTIME	Deceleration time	0.1s
3	MBOXPARAM	Refer to section 4.9.	-
4	MBOXVALUEWRITE	Refer to section 4.9.	-

* 100% = $\frac{f}{f_{max}}$ (Base frequency), f_{max} (Maximum frequency) limits this value.

4.6.1. Analog Output Attribute

Table 9 Analog Output Attribute Table

Attribute	Type	Contents
1	Byte	Object Configuration Bit 0 = COS_enabled (1) Bit 1 = unused Bit 2 = unused Bit 3 = unused Bit 4 = unused Bit 5 = unused Bit 6 = unused Bit 7 = unused
2	Byte	Object Status Bit 0 = reliable (0) / unreliable (1) Bit 1 = override active (1) Bit 2 = saturated high (1) (JCI use only) Bit 3 = saturated low (1) (JCI use only) Bit 4 = unused Bit 5 = unused Bit 6 = unused Bit 7 = unused
3	Float	Current Value
4	Float	Low Linear Ranging Parameter (JCI use only)
5	Float	High Linear Ranging Parameter (JCI use only)

* Added shading functions are not supported (The response is "N10").

4.6.2. Analog Output COS Works

Analog Output and Binary Output points have simple COS.

If the COS_enabled bit is set then COS will be reported whenever the object status changes.

4.7. Binary Output Object

Binary Output is used for the run/stop of VFFS1 etc. COS alarm and warning functions are also enabled.

Overriding of analog outputs will be accepted and acknowledged with the active override flag set. Upon release of the override command, the binary output point will reset the active override flag, retain the override value, and not return to its pre-override value.

Table 10 Binary Output Objects Table

Object number	Object name	VFFS1	Contents
0	RO1CMD	FL (TB)	0 = OFF, 1 = ON (<i>F 130</i> = 38)
1 *	-	-	-
2	RUNSTOPCMD	-	0 = Stop, 1= Run
3	FWDREVCMD	-	0 = Fwd, 1= Rev
4	FAULTRESET	-	1 = Reset
5	MBOXREAD	-	Refer to section 4.9.
6	MBOXWRITE	-	Refer to section 4.9.
7	SP1PRESET **	-	Preset speed operation frequencies 1
8	SP2PRESET **	-	Preset speed operation frequencies 2
9	SP3PRESET **	-	Preset speed operation frequencies 3
10	FRCMDMOD	-	1 = Metasys [®] N2 Enabled
11	RSCMDMOD	-	1 = Metasys [®] N2 Enabled

* Reserved (The response is "A").

** Preset speed operation frequencies (1 - 7) are set by bit of the object number 7 - 9.

4.7.1. Binary Output Attribute

Table 11 Binary Output Attribute Table

Attribute	Type	Contents
1	Byte	Object Configuration Bit 0 = COS_enabled (1) Bit 1 = normal state Bit 2 = unused Bit 3 = unused Bit 4 = unused Bit 5 = unused Bit 6 = unused Bit 7 = unused
2	Byte	Object Status Bit 0 = reliable (0) / unreliable (1) Bit 1 = override active (1) Bit 2 = unused Bit 3 = unused Bit 4 = normal (0) / alarm (1) (JCI use only) Bit 5 = normal (0) / trouble (1) (JCI use only) Bit 6 = current state Bit 7 = unused
3	Integer	Minimum On-time (sec) (0-65535)
4	Integer	Minimum Off-time (sec) (0-65535)
5	Integer	Maximum Cycles/Hour
6	Integer	Interstage on delay(sec)(0-65535) (JCI use only)
7	Integer	Interstage off delay(sec)(0-65535) (JCI use only)

* Added shading functions are not supported (The response is "N10").

4.7.2. Binary Output COS Works

Binary Output and Binary Output points have simple COS.

If the COS_enabled bit is set then COS will be reported whenever the object status changes.

4.8. Error Message Format

The negative responses have the following format, followed by the error codes and their meaning.

CHAR1 Start of message..... N
 CHAR2 Error code (Refer to Table 12)
 CHAR1 End of message (CR)

Table 12 Error Code Table

Error Table	Contents
00	MTS002Z has reset and is waiting for the "Identify Yourself" command.
01	Undefined Command error.
02	Invalid message (include checksum error).
05	Data field error: message size not correct for command type.
10	Invalid Data: The fields contains a value that is out of the expected range. Confirm that the requested point exists or a commanded value is not out of range.

4.9. VFFS1 Parameter access

Using below Metasys® N2 objects, inverter parameters can be read and written.

Table 13 Error Code Table

Object	Object number	Object name	Note
Analog Output	3	MBOXPARAM	The communication number (hex.) of the access parameter is set.
Analog Input	13	MBOXVALUEREAD	The read value is set.
Analog Output	4	MBOXVALUEWRITE	Set the write value.
Binary Output	5	MBOXREAD	The parameter value specified by MBOXPARAM is read.
Binary Output	6	MBOXWRITE	The value of MBOXVALUEWRITE is written to the parameter specified by MBOXPARAM.

Example 1) Read the deceleration time ($dE\zeta$, Comm. No. 0010)

- Override "16" as the communication number to MBOXPARAM (Analog Output Object - 3).
* The communication number uses the value of a decimal number set to "10" by the hexadecimal number. $0x0010 = 16$ dec.
- Override "1" to MBOXREAD (Binary Output Object - 5).
- The read value set to MBOXVALUE (READ Analog Input Object - 13). Its unit is 0.1s.

Example 2) Write "50.0Hz" to VIB input point 2 ($F\zeta I\zeta$, Comm No. 0213)

- Override "531" as the communication number to MBOXPARAM (Analog Output Object - 3).
* $0x0213 = 531$ dec.
- Override "5000" to MBOXVALUEWRITE (Analog Output Object - 4).
* $5000 = 50.00\text{Hz}$, unit is 0.01Hz
- Override "1" to MBOXWRITE (Binary Output Object - 6).

* In case of parameter access, the time from receipt of the last character of a message to the transmission of the first character of the response is about 40ms.

* A response is "N10" when a communication number does not exist.

5. VFFS1 Trip code

Code		Description	Display
Data (Dec.)	Data (Hex.)		
0	0	No error	<i>nErr</i>
1	1	Over-current during acceleration	<i>OC1</i>
2	2	Over-current during deceleration	<i>OC2</i>
3	3	Over-current during constant speed operation	<i>OC3</i>
4	4	Over-current in load at startup	<i>OCL</i>
5	5	Short circuit in arm	<i>OCR</i>
8	8	Input phase failure	<i>EPH1</i>
9	9	Output phase failure	<i>EPHO</i>
10	A	Over-voltage during acceleration	<i>OP1</i>
11	B	Over-voltage during deceleration	<i>OP2</i>
12	C	Over-voltage during constant speed operation	<i>OP3</i>
13	D	Over-LOAD in inverter	<i>OL1</i>
14	E	Over-LOAD in motor	<i>OL2</i>
16	10	Overheat trip	<i>OH</i>
17	11	Emergency stop	<i>E</i>
18	12	EEPROM fault 1 (writing error)	<i>EEP1</i>
19	13	EEPROM fault 2 (reading error)	<i>EEP2</i>
20	14	EEPROM fault 3 (internal fault)	<i>EEP3</i>
21	15	RAM fault	<i>Err2</i>
22	16	ROM fault	<i>Err3</i>
23	17	CPU fault	<i>Err4</i>
24	18	Communication error trip	<i>Err5</i>
26	1A	Current detector fault	<i>Err7</i>
27	1B	Optional circuit board type error	<i>Err8</i>
29	1D	Small-current trip	<i>UC</i>
30	1E	Trip due to under-voltage in main circuit	<i>UPI</i>
32	20	Over-torque trip	<i>Ot</i>
34	22	Ground fault trip (hardware detection)	<i>EF2</i>
37	25	Over-current flowing in element during acceleration	<i>OC1P</i>
38	26	Over-current flowing in element during deceleration	<i>OC2P</i>
39	27	Over-current flowing in element during operation	<i>OC3P</i>
41	29	Inverter type error	<i>EtYP</i>
46	2E	External thermal input	<i>OH2</i>
47	2F	VIA cable break	<i>SOUL</i>
50	32	Break in an analog signal cable	<i>E-18</i>
51	33	CPU fault	<i>E-19</i>
52	34	Excess torque boost	<i>E-20</i>
53	35	CPU fault	<i>E-21</i>
84	54	Auto-tuning error	<i>EtN1</i>

6. Specifications

< Environmental specification >

Item	Specification
Service environment	Conforms to VFFS1
Operation temperature	Conforms to VFFS1
Storage temperature	-25 to +65°C
Relative humidity	20 to 93% (free from condensation and vapor)
Vibration	5.9m/s ² (0.6G) or less (10 to 55 Hz) (To be complied with JIS C0040.)

< MTS002Z terminal specification >

Item	Specification	Note
Communication between inverter	VFFS1	Only one board connection is available.
Applicable model		
Communication method	MODBUS-RTU	Set the inverter parameter
Baud rate	19200bps	
Parity	Even number	
Control power supply	5 V _{DC}	Supplied from inverter
Logic input terminal	2 circuits (F,R) Slide switch (SW) enable to select logical configurations (Source/Sink).	Not isolated
Logic output terminal	Nothing	
Relay contact output terminal	1 circuit (FL): 30V _{DC} -0.5A 250V _{AC} -1A (cosφ = 1) 250V _{AC} -0.5A (cosφ = 0.4)	Isolated
Analog input terminals	1 circuit (VIB): 10V _{DC} (R _{IN} = 30kohm)	Not isolated
Analog output terminals	Nothing	
Power supply output	24V _{DC} -50mA	Current limit function

< MTS002Z network specification >

Item	Specification
Maximum node	255 nodes (32 nodes per segment)
Communication baud rate	9600bps
Bias resistor and termination	Local bias resistors are mounted. Termination resistor (120 ohm) can be select by SW.
Terminal block	Detachable terminal block 4-pole (5.08mm pitch) Manufacturer: PHOENIX CONTACT Type-Form : MSTB 2,5/4-ST-5.08