

---

**TOSVERT VF-FS1 series**

---

**LONWORKS<sup>®</sup> Communication option LIU007Z**

---

**Instruction Manual**

---



NOTICE



1. Make sure that this instruction manual is delivered to the end user of LONWORKS communication option.
2. Read this manual before installing or operating the LONWORKS communication option. Keep it in a safe place for reference.
3. All information contained in this manual are subject to change without notice. Please confirm the latest information on our web site.

## Safety precautions

On the inverter and in its instruction manual, important information is contained for preventing injuries to users, damages to assets, and for proper use of the device.

Read the instruction manual attached to the inverter along with this instruction manual to completely understand the safety precautions, the symbols and indications shown below. Please adhere to the contents of these manuals at all times.





### Explanation of markings

Marking	Meaning of marking
 Danger	Indicates that errors in operation may lead to death or serious injury.
 Warning	Indicates that errors in operation may lead to injury (*1) to people or that these errors may cause damage to physical property. (*2)

(\*1) Such things as injury, burns or shock that will not require hospitalization or long periods of outpatient treatment.

(\*2) Physical property damage refers to wide-ranging damage to assets and materials.





### Meanings of symbols

Marking	Meaning of marking
	Indicates prohibition (Do not do it). What is prohibited will be described in or near the symbol in either text or picture form.
	Indicates something mandatory (must be done). What is mandatory will be described in or near the symbol in either text or picture form.
	Indicates danger. What is dangerous will be described in or near the symbol in either text or picture form.
	Indicates warning. What the warning should be applied to will be described in or near the symbol in either text or picture form.



■ **Limitation of use**

<b>⚠ Safety precaution</b>	
▼ Never use this unit with any device other than TOSVERT VF-FS1 series inverters. Doing so may cause an accident.	



■ **Handling in general**

<b>⚠ Danger</b>	
 Never Disassemble	▼ Never disassemble, modify or repair the product. Disassembling the product may cause electric shocks, fire or injuries. For repairs, call your sales/repair agency.
 Prohibited	▼ Do not open the front cover on the inverter while the inverter power is on. It may lead to electric shocks. ▼ Do not remove this option from VF-FS1 while the power is on. It may lead to electric shocks. ▼ Do not put or insert foreign objects such as waste cable, bars or wires into the product. It may lead to electric shocks or fire. ▼ Do not splash water over the product, and do not wipe the body with a wet cloth. It may lead to electric shocks or fire.
 Mandatory	▼ Turn off the power immediately in case of any abnormalities such as smoke, smell or abnormal noise. Neglect of these conditions may lead to fire. For repairs, call your sales/repair agency. ▼ Do not touch the sharp portions (such as leads of parts on the board, the corner of board, or etc.) on this option. It may lead to injuries.
<b>⚠ Warning</b>	
 Mandatory	▼ This option is an electrostatic discharge sensitive device. Handle it, where the environment is protected against electrostatic electricity. Otherwise, permanent damage to device will result.





■ **Transportation and installation**

<b>⚠ Danger</b>	
 Prohibited	▼ Do not apply a dropping shock or other physical shocks. Otherwise, damage or malfunction will result. ▼ Do not install or operate the inverter if it is damaged or any part of it is missing. Operating a defective inverter may lead to electric shocks or fire. For repairs, call your sales/repair agency. ▼ Do not put any flammable material near the product. It may catch fire due to the product sparking in the case of a malfunction.
 Mandatory	▼ Use this product under the environmental conditions prescribed in the instruction manual. Usage it under any other conditions may result in malfunction. ▼ An emergency stop device must be installed that fits with system specifications (e.g. shut off input power then engage mechanical brake). Operation cannot be stopped immediately by the inverter or this unit alone, thus risking an accident or injuries. ▼ Install this option into VF-FS1 and secure it by tightening the terminal board fixing screws to the specified torque. Otherwise, it may cause the product falling, the damage, or malfunctions. ▼ When installing this option, do not touch its sharp portions such as leads of parts on the board, the corner of board or etc. Doing so may result in injury.



■ **Wiring**

 <b>Warning</b>	
 Mandatory	<ul style="list-style-type: none"> <li>▼ Electrical construction work must be done by a qualified expert. Connection of input power by someone who does not have expert knowledge may result in electric shocks or fire.</li> <li>▼ Turn off input power before wiring. Wait at least 10 minutes and make sure that the charge lamp (on the inverter unit) is no longer lit. Otherwise, it may lead to electric shocks.</li> <li>▼ Tighten the screws on the terminal blocks to the specified torque when connecting cables to terminal blocks. Otherwise, it may lead to fire.</li> </ul>

■ **Operations**

 <b>Danger</b>	
 Prohibited	<ul style="list-style-type: none"> <li>▼ Do not pull on the cable and connector. It may cause damage or malfunctions.</li> </ul>
 Mandatory	<ul style="list-style-type: none"> <li>▼ Use this option under the environment specified in the instruction manual. Usage under the environment other than them may cause damages or malfunctions or an accident.</li> <li>▼ Use an additional safety device with your inverter or system to prevent a serious accident due to the unit malfunctions. Usage without an additional safety device may cause an accident.</li> </ul>
 <b>Warning</b>	
 Mandatory	<ul style="list-style-type: none"> <li>▼ Set up “Communication error trip function (see below)” to stop the inverter when the option unit is deactivated by an unusual event such as an operating error, power outage, failure, etc.                         <ul style="list-style-type: none"> <li>- Communication error trip time (F803, see the inverter instruction manual for details)</li> <li>- Receive heart beat timer (See the VF-FS1 LONWORKS Communication Function Manual for details)</li> </ul>                         Deactivated option unit may cause an accident, if the “Communication error trip function” is not properly set up.                     </li> <li>▼ Make sure that the operation signals are STOP before clearing the inverter’s fault. The motor may suddenly start and that may result in injuries.</li> </ul>

■ **Disposal**

 <b>Warning</b>	
 Mandatory	<ul style="list-style-type: none"> <li>▼ If you dispose off this unit, have it done by a specialist in industrial waste disposal*. Improper disposal may result in explosion of capacitors or produce noxious gases, resulting in injuries. (* ) Persons who specialize in the processing of waste and known as “Industrial Waste Product Collectors and Transporters” or “Industrial Waste Disposal Persons.” If the collection, transport and disposal of industrial waste is done by someone who is not licensed for that job, it is a punishable violation of the law (Laws in regard to cleaning and processing of waste materials).</li> </ul>

■ **Notes on operation**

<b>Notes</b>	
	<ul style="list-style-type: none"> <li>▼ Avoid installing in a place where ambient temperature or/and humidity change sharply.</li> <li>▼ Keep the transmission cable separate from the power cable of the inverter to prevent the inverter from malfunctioning due to electromagnetic noise.</li> <li>▼ Ground of SHLD terminal on this option at the grounding terminal separated from those of inverters and motors. It may cause malfunction due to noise.</li> </ul>

# Preface

Thank you for purchasing the “LONWORKS communication option (LIU007Z)” for TOSVERT VF-FS1 inverter. By installing this board into the VF-FS1, data communication can be made with a host computer or other device via LONWORKS network.

Before using this unit, carefully read this instruction manual in order to completely and correctly utilize excellent performance of this unit. Besides this instruction manual, the “VF-FS1 LONWORKS Communication Function Manual” which includes the contents to install into LONWORKS network is prepared. If it is required, please contact with our branch offices, sales offices or web site “www.inverter.co.jp”.

(“VF-FS1 LONWORKS Communication Function Manual”: E6581373)

After reading this instruction manual, please keep it handy for future reference.

- \* Echelon®, LONWORKS®, LonTalk®, Neuron®, LONMARK®, LONMARK Logo® are the registered trademarks or the trademarks of Echelon Corporation in the USA and other countries.
- \* LONMARK and LONMARK Logo are managed, granted, and used by LONMARK International under a license granted by Echelon Corporation.

- Part numbering

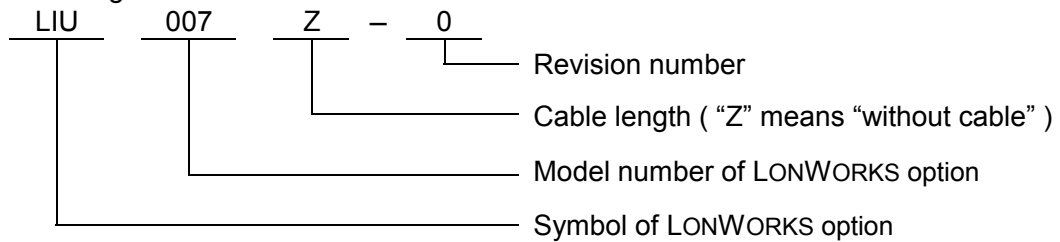

- Accessory check list

LONWORKS communication option is shipped together with the following accessories. On opening the packing case, check to see if the following accessories are contained or not.

(1) Instruction manual

English (E6581371) ..... 1 copy (This book)

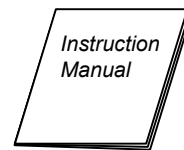

(2) Cabling label & Name plate ..... 1 sheet.

(1 cabling label and 2 name plates)

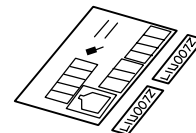

(3) Insulating sheet ..... 1 sheet.

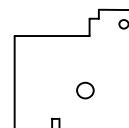

(4) Neuron ID Label ..... 4 sheets.

(These are stuck on the unit)



---

# Table of Contents

---

1. Overview .....	6
2. Names and functions .....	6
2.1. Service pin .....	6
2.2. Use of RS485 communication port .....	6
2.3. Description of terminals .....	7
3. Installation and Setup .....	8
3.1. Installation method .....	8
3.2. VF-FS1 communication parameters .....	9
3.3. Network cable connection .....	9
3.4. Network configuration .....	10
3.5. Termination resistor .....	11
3.6. Wiring of a control terminal .....	11
4. Before making a service call .....	12
4.1. Display of service LED .....	12
4.2. Other problems .....	12
5. Specifications .....	13
6. Warranty .....	14

# 1. Overview

LONWORKS technology is a network control system concept developed by Echelon Corporation, LONWORKS network provides Local Operating Network that is superior in the distributed control. Each device works in a peer-to-peer fashion on LONWORKS network. This LONWORKS option is equipped with the LONWORKS Smart Transceiver (Neuron Chip).

# 2. Names and functions

The drawing below shows names and functions of main parts.

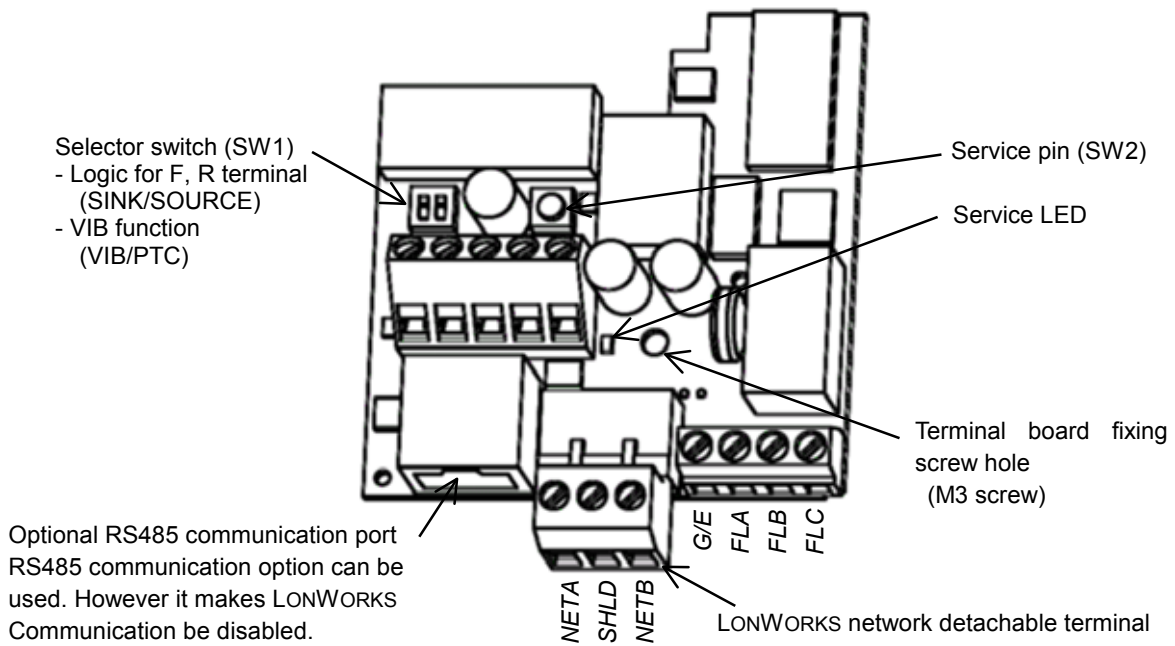

## 2.1. Service pin

Service pin is used for commissioning device. Use SW2 on the option board.

<b>⚠ Danger</b>	
<b>⚠</b> Mandatory	<ul style="list-style-type: none"> <li>▼ Operate Service switch only when a cover for the main circuit terminal is attached. Otherwise, it may lead to electric shocks.</li> <li>▼ Operate Service switch using the non-conductive stick. When it is operated with a conductive stick. Otherwise, it may lead to electric shocks.</li> </ul>

## 2.2. Use of RS485 communication port

Serial communication (2-wire RS485) option can be used. However, while it is connected, the internal communication line is switched to RS485 then the communication via LONWORKS network is disabled. In this case, communication error trip time (*F803*) is also active. Use RS485 serial communication option specified by Toshiba.

**2.3. Description of terminals**

<Control terminals specification>

Terminal symbol	Function	Electrical specifications	Internal circuits
NETA NETB	LONWORKS transmission data / reception data	no polarity	
SHLD	LONWORKS communication shield terminal.	This terminal is not connected to other circuits in this board.	
G/E	Grounding terminal	Connect to network ground	
F	Multifunctional programmable contact input.	No voltage contact input 24V <sub>DC</sub> , 5mA or less	
R	SINK/SOURCE can be selected with SW1.	N.B. Use contact parts for low current.	
VIB	Multifunction programmable analog input. with internal pull-up resistor for PTC	0 to 10V <sub>DC</sub> input  Using this terminal as PTC input, set SW1 to PTC side and set the parameters (F 5 4 5 and F 5 4 5) to proper value.	
CC	Control circuit's equipotential terminal		
P24	24 V <sub>DC</sub> power supply output	24V <sub>DC</sub> -50mA	
FLA FLB FLC	Multifunctional programmable relay contact outputs	1c contact 30V <sub>DC</sub> -0.5A 250V <sub>AC</sub> -1A (cosφ =1 ) 250V <sub>AC</sub> -0.5A (cosφ =0.4)	

<b>Danger</b>	
 Prohibited	▼ Do not change switches settings while the power is on. It may lead to electric shocks or damage.
 Mandatory	▼ Turn off the motor operation signals before setting the parameter and the switch (SW1), when changing the VIB function. Otherwise, the motor may suddenly start and that may result in injuries.

### 3. Installation and Setup

#### 3.1. Installation method

Install the LONWORKS communication option to VF-FS1 as follows.

- (1) Turn off the input power of VF-FS1 and wait for at least 10 minutes and then check that the CHARGE lamp on VF-FS1 is no longer lit.
- (2) Open the VF-FS1 front cover, remove the terminal board fixing screw and take off the VF-FS1 standard terminal board.  
(Be careful not to lose the terminal board fixing screw when removed since it may be used again.)
- (3) Perform wiring an inverter before installing LONWORKS communication option.
- (4) Please attach the insulating sheet in VF-FS1.  
(Fix to the terminal board fixing screw hole and PWB catch pin.)
- (5) Install the LONWORKS communication option over the insulating sheet and secure it with the board fixing screw (tightening torque of M3 tapping screw: 0.7 to 0.8Nm).
- (6) Stick the cabling label for LONWORKS communication option on the standard cabling label stuck on the reverse side of the VF-FS1 front cover. And stick the LONWORKS communication option nameplate near the standard nameplate. (Be careful not to cover slits on the VF-FS1 enclosure.  
N.B.: To install or remove the terminal board, make it slide in or out in parallel with board.

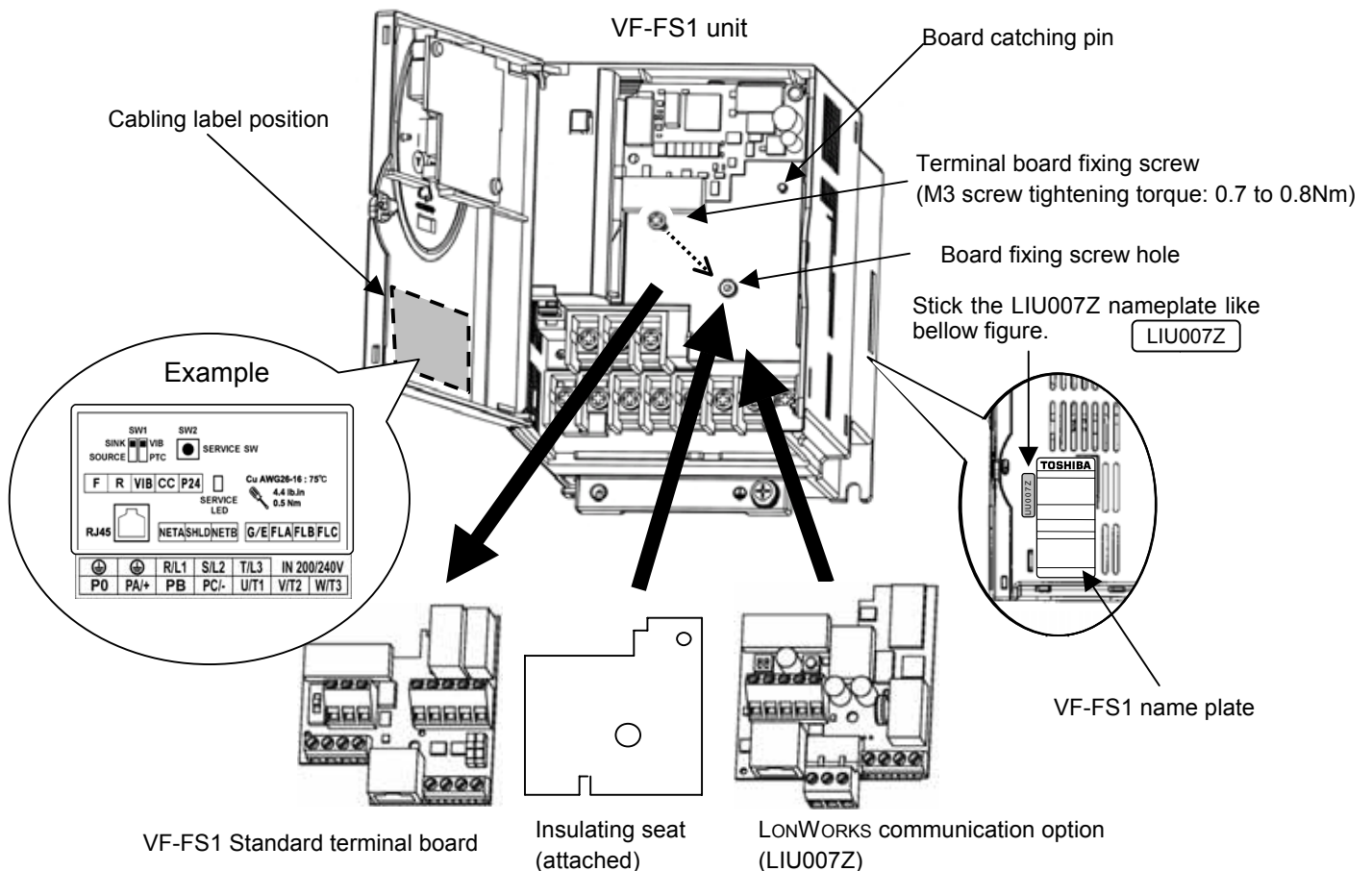

### 3.2. VF-FS1 communication parameters

Set up the inverter parameters as follows. To update, reset the power of inverter. If these parameters are not set to correct value, this unit can not work normally.

Title	Function	Description
<i>Cn0d</i>	Command mode selection	While LONWORKS communication option is installed into VF-FS1, The network command and setpoint are prior to <i>Cn0d/Fn0d</i> . VF-FS1 front panel operation is prior when LOC lamp on the front panel turns on.
<i>Fn0d</i>	Setpoint mode selection	
<i>F800</i>	Communication speed	Set "1: 19200bps" (default).
<i>F801</i>	Parity	Set "1: Even" (default).
<i>F803</i>	Communication error trip time	Set communication time out period.
<i>F829</i>	Communication protocol	<b>Set "1: MODBUS-RTU"</b>
<i>F851</i>	Operation at network error	Set the behavior when "Receive heart beat timer" overflow occurred.

<b>⚠ Warning</b>	
 Mandatory	▼ Set up "Communication error trip function ( <i>F803</i> , see the inverter instruction manual for details)" to stop the inverter when this option unit is deactivated by an unusual event such as tripping, an operating error, power outage, failure, etc. Deactivated option unit may cause an accident, if the "Communication error trip function" is not properly set up.

### 3.3. Network cable connection

Connect the LONWORKS network cable to LONWORKS communication option as follows.

(1) Cable selection (a twisted pair cable with shield)

Use Level 4/22 AWG cable for the network cable.

- Recommended cable

Manufacturer: Showa Electric Wire & Cable Co., Ltd.

Model name: LW221S, 22AWG, 1P, With shield, Standard 300m/reel

Use 0.75mm<sup>2</sup> wire for grounding to the earth terminal (G/E) of the board.

(2) Terminal blocks

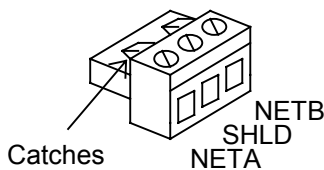

Manufacturer: PHOENIX CONTACT

Model name: MSTB 2,5/3-ST-5.08

- Communication terminal NETA, NETB

Connect LONWORKS transmission/reception data cable.

Polarity of the communication terminals NETA and NETB does not have to be considered.

- Communication shield terminal SHLD

Connect the shield of network cable. Refer to next section for grounding.

- G/E terminal

Connect the network ground.

(3) Connection

Cable sheath should be peeled off by about 7mm.

For wiring work, use a flat blade screwdriver with a 0.6mm thick and 3.5mm width blade.

Tightening torque for the terminal block is 0.5Nm.

**3.4. Network configuration**

Make up the network as follows.

- Transmission/reception signals (NETA, NETB)

Make up the communication path by connecting all transmission/reception data cables (No polarity).

- Grounding the shield of cable (SHLD)

Connect the all shield lines of network cable. Ground through a metal film resistor of 470k ohm, 1/4W, 10% or more accurate so that static electricity does not increase (at the point where it separated from the power ground of inverters or motors).

- Termination resistor (Please refer to “3.5. Termination resistor”)

Only one terminal resistor is needed for the segment of the free topology. It can also be placed wherever it is on the free topology segments. (2 termination resistors in case of Bus topology)

- Network cable length (for recommended cable usage)

Free-Topology: device-to-device distance is 400m or less, total wire length is 500m or less

Bus-Topology: total wire length is 1400m or less, stub length is 3m or less.

- Connection image

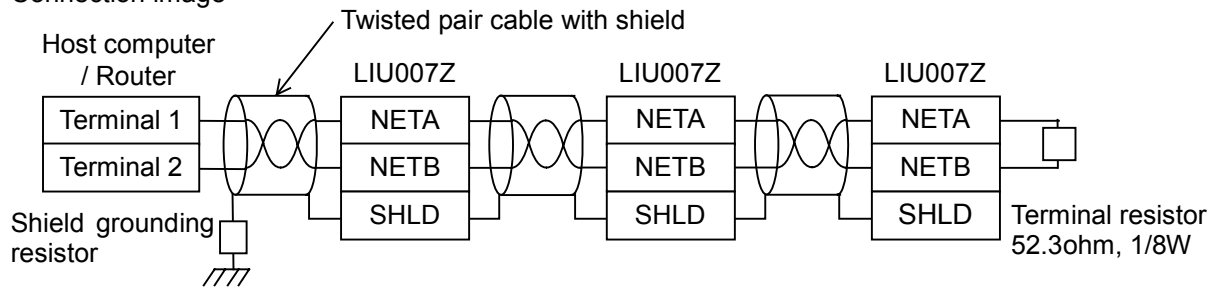

Network configuration is shown in the figures below. This LONWORKS communication option has TP/FT-10 channel type transceiver. The free topology wiring supported by the TP/FT-10 channel type accommodates bus, star, loop, or several combinations of these topologies shown in below

- Network configuration example

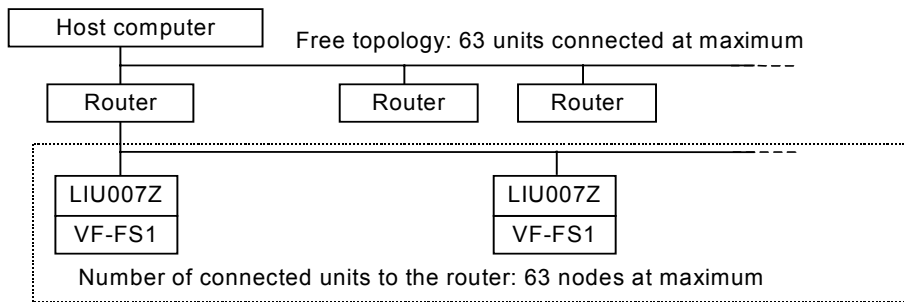

- The free topology wiring example.

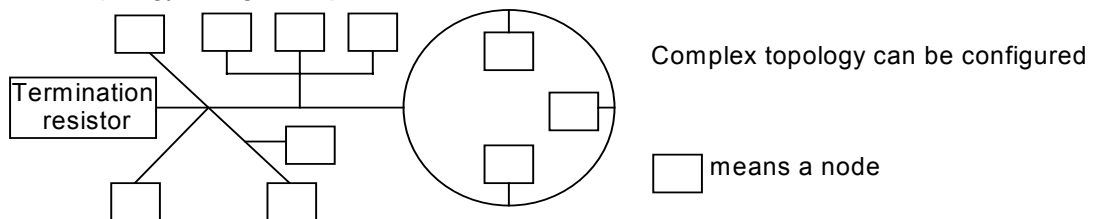

N.B.: Do not connect the SHLD terminal to the power ground of inverters or other units.

Keep the network cables 20cm or more separate from the power cables to prevent from malfunctioning due to electromagnetic noise.

### 3.5. Termination resistor

Terminate the network bus with about 52.3ohm impedance to minimize the reflections. There are two choices for the termination.

1. Free Topology Network Segment

Only one termination and may be placed anywhere on the free topology segment.

RC network (Following figure), with  $R1 = 52.3ohm \pm 1\%$ , 1/8W

2. Doubly Terminated Bus Topology Segment.

It is necessary to terminate at both ends of a twisted pair bus.

RC network (Following figure), with  $R1 = 105ohm \pm 1\%$ , 1/8W

Terminal circuit

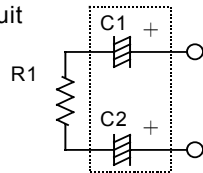

C1 and C2 are required for connection to link power network.

C1, C2: Aluminum-electrolytic type  
100uF, 50V min

### 3.6. Wiring of a control terminal

Observe the following when wiring.

- Use 0.3 to 1.5mm<sup>2</sup> solid/stranded wire (AWG 22 to 16) for control cables.
- Remove the sheath of a cable about 7mm (6mm for FLA, FLB, FLC and G/E) from the end of cable.
- Use a flat-headed screwdriver with its blade 0.6mm in thickness and 3.5mm in width.
- Screw tightening torque for the terminal block screws should be 0.5 to 0.6Nm.

N.B.: ~~Keep the control signal cables 20cm or more separate from the power cables to prevent from malfunctioning due to electromagnetic noise.~~

N.B.: Provide an inter-lock system stated in below, when using a programmable controller that has the open collector output.

When the programmable controller is turned off with the inverter is on, the difference between each control power potential will cause wrong signals to the inverter as shown in below figure. Provide an inter-lock so that the programmable controller cannot be turned off when the inverter power is alive.

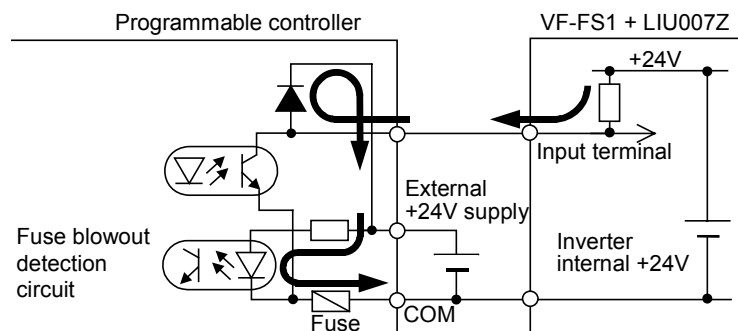

## 4. Before making a service call

If a problem arises, please see the following trouble-shooting tables. If the problem can not be solved, please contact a Toshiba distributor.

### 4.1. Display of service LED

Service LED indicates the condition of nodes.

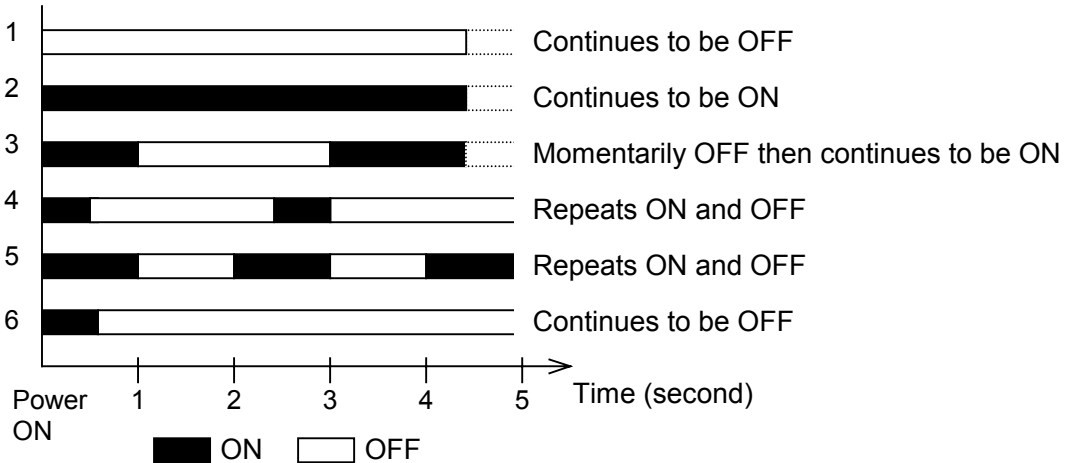

No	Phenomenon	Problem & Solutions
1	Although the inverter is turned on, LED remains OFF.	Check the connection the inverter and the optional unit. If abnormality is not found after checking, it needs to be repaired.
2	LED continues to be ON after the inverter is turned on.	
3	LED is ON then OFF when the inverter is turned on, and it continues to be ON.	Internal application program is abnormal. It needs to be repaired.
4	LED blinks every 0.5 second.	A watch dog is suspected. If the same indication appears after resetting the power, it needs to be repaired.
5	LED blinks every 1 second.	This is a normal action of the "Unconfigured" device. If the device is not "Unconfigured", Internal application program is broken. It needs to be repaired.
6	LED momentarily turns ON then continues to be OFF.	When the program is in the condition of "Configured" status, LED momentarily turns ON when the inverter is turned on. Then the LED continues to be OFF for some seconds. The node indicates "Configured" status that means the normal condition.
-	LED Flickers	CPU is abnormal. It needs to be repaired.
-	LED is turned on while pushing service pin.	Normal operation while pushing service pin.

### 4.2. Other problems

Phenomenon	Problem and Solutions
No replying from LONWORKS communication option	Check proper termination resistor is installed on the network. (See section 3.5.) After checking the service LED status, see the previous section.
Communication error in network variable	Remove RS485 communication option from RJ45. Check the inverter parameter setting (refer to section 3.2). Check the network cables are not near the power cables.

## 5. Specifications

< Environmental specification >

Item	Specification
Service environment	Conforms to VF-FS1
Operation temperature	Conforms to VF-FS1
Storage temperature	-25 to +65°C
Relative humidity	20 to 93% (free from condensation and vapor)
Vibration	5.9m/s <sup>2</sup> (0.6G) or less (10 to 55 Hz) (To be complied with JIS C0040.)

< LONWORKS communication option (LIU007Z) side >

Item	Specification	Note	
Communication between inverter	Applicable model	VF-FS1	Only one board connection is available.  Set the inverter parameter (refer to section 3.2)
	Communication method	MODBUS-RTU	
	Baud rate	19200bps	
	Parity	Even number	
Control power supply	5 V <sub>DC</sub>	Supplied from inverter	
Logic input terminal	2 circuits (F,R) Slide switch (SW1) enable to select logical configurations (Source/Sink).	Not isolated	
Logic output terminal	Nothing		
Relay contact output terminal	1 circuit (FL): 30V <sub>DC</sub> -0.5A 250V <sub>AC</sub> -1A (cosφ =1 ) 250V <sub>AC</sub> -0.5A (cosφ =0.4)	Isolated	
Analog input terminals	1 circuit (VIB): 10V <sub>DC</sub> (R <sub>IN</sub> = 30kohm)	Not isolated	
Analog output terminals	Nothing		
Power supply output	24V <sub>DC</sub> -50mA	Current limit function	

< Network side >

Item	Specification	Notes
Transceiver Channel type	TP/FT-10 type (Free topology transceiver)	78kbps ANSI/EIA/CEA 709.3
Communication signal	2 wires plus shield	NETA, SHLD, NETB
Transmission distance (Free topology)	Between devices: 400m at maximum Total cable length: 500m at maximum	When recommended cable is used: Level 4/22AWG
Transmission distance (Bus topology)	Total cable length: 1400m at maximum Stub length: 3m at maximum	When recommended cable is used: Level 4/22AWG
Number of connected nodes	Free topology 63 nodes at maximum	Because a host and routers are counted as one board, the option can be connected up to 63 nodes.
Protocol	LonTalk	ANSI/EIA 709.1
Address and related items	Number of domains: 2 Number of address entries: 37 Number of alias tables: 8	
Network variables	Number of transmission data: 17 Number of receiving data: 8 Number of configuration property: 12	LONMARK Variable Speed Motor Drive functional profile.
Service pin	Mechanical switch (SW2)	Used for notification of Neuron ID to the host.
Terminal block	Detachable terminal block 3-pole	Applicable terminal block Manufacturer: PHOENIX CONTACT Type-Form : MSTB 2,5/3-ST-5.08

---

## **6. Warranty**

---

Any part of LONWORKS communication option that is proved to be defective will be repaired free of charge under the following conditions:

1. This product will be repaired free of charge, if problem/fault occurs under normal handling within one year of delivery and is caused obviously by a design or manufacturing defect.
2. The warranty applies only to the delivered product.
3. For the following kinds of failure or damage, the repair cost shall be borne by the customer even within the warranty period.
  - i) Failure or damage caused by improper or incorrect use or handling, or unauthorized repair or modification of the inverter.
  - ii) Failure or damage caused by the unit falling or an accident during transportation after the purchase.
  - iii) Failure or damage caused by fire, salty water or wind, corrosive gas, earthquake, storm or flood, lightning, abnormal voltage supply, or other natural disasters.
  - iv) Damage due to the use of LONWORKS communication option for non-intended purposes.
4. If an additional warranty is provided then those conditions will also apply.

