

TOSVERT VF-AS1/PS1

DeviceNet Option Function Manual

DEV002Z-1

* The data given in this manual are subject to change without notice.

Toshiba Inverter Corporation

© Toshiba Inverter Corporation 2006
All rights reserved.

Contents

1. INTRODUCTION	3
2. CONNECTION INFORMATION	4
2.1. CONNECTION SIZES	4
2.2. EXTERIOR OVERVIEW	4
2.3. SETTING A MAC ID NUMBER AND A NETWORK BAUD RATE	5
2.4. DEVICENET LED INDICATOR	6
2.5. COMMUNICATIONS-RELATED PARAMETERS	7
3. OBJECT SPECIFICATIONS	8
3.1. IDENTITY OBJECT	9
3.1.1. Identity Object Class Attributes	9
3.1.2. Identity Object Instance Attributes	9
3.1.3. Identity Object Common Services	9
3.1.4. Identity Object Specific Services	9
3.2. MESSAGE ROUTER	10
3.2.1. Message Router Class Attributes	10
3.2.2. Message Router Instance Attributes	10
3.2.3. Message Router Common Services	10
3.2.4. Message Router Specific Services	10
3.3. DEVICENET OBJECT	11
3.3.1. DeviceNet Object Class Attributes	11
3.3.2. DeviceNet Object Instance Attributes	11
3.3.3. DeviceNet Object Common Services	11
3.3.4. DeviceNet Object Specific Services	11
3.4. ASSEMBLY OBJECT	12
3.4.1. Assembly Object Class Attributes	12
3.4.2. Assembly Object Instance Attributes	12
3.4.3. Assembly Object Common Services	12
3.4.4. Assembly Object Specific Services	12
3.4.5. Assembly Instance Details (<i>F830</i>)	13
3.4.5.1. Instance 20/70 - DeviceNet Standard (4 bytes, parameter <i>F830</i> = 0)	13
3.4.5.2. Instance 21/71 - DeviceNet Standard (4 bytes, parameter <i>F830</i> = 1)	14
3.4.5.3. Instance 100/150 - Toshiba Specific (4 bytes, parameter <i>F830</i> = 2)	16
3.4.5.4. Instance 101/151 - Toshiba Specific (8 bytes, parameter <i>F830</i> = 3)	18
3.4.5.5. Instance 102/152 - Toshiba Specific (12 bytes, parameter <i>F830</i> = 4)	20
3.4.5.6. How to use Instance 102/152	21
3.4.6. The outline of the parameter <i>F831 - F836, F841 - F846</i> setup value	22
3.4.6.1. FA06 (command word 1 from internal option PCB)	22
3.4.6.2. FA23 (command word 2 from internal option PCB)	22
3.4.6.3. FA07 (frequency reference from internal option PCB)	23
3.4.6.4. FA33 (torque reference from internal option PCB)	23
3.4.6.5. FA50 (Terminal output data from comm.)	23
3.4.6.6. FA51 (Analog output (FM) data from comm.)	23
3.4.6.7. FA52 (Analog output (AM) data from comm.)	23
3.4.6.8. FD01 (Inverter status (real time))	24
3.4.6.9. FD00 (Output frequency (real time))	24
3.4.6.10. FD03 (Output current (real time))	24
3.4.6.11. FE36 (Analog input value VI/II)	25
3.4.6.12. FE37 (RX Input)	25
3.4.6.13. FE60 - FE63 (My Monitor)	25
3.4.6.14. FE14 (Cumulative run time)	25
3.4.6.15. FE40 (Analog output (FM))	25
3.4.6.16. FC91 (Alarm code)	26
3.4.6.17. FD06 (Input TB Status)	26
3.4.6.18. FD07 (Output TB Status)	26
3.5. CONNECTION OBJECT	27
3.5.1. Connection Object Attributes	27
3.5.2. Connection Object Instance Attributes	27
3.5.2.1. Explicit Messaging Connection Object Instance Attributes (Instance 1)	28
3.5.3. Connection Class Common Services	28
3.5.3.1. Poll Connection Object Instance Attributes (Instance 2)	29
3.5.4. Connection Class Common Services	29
3.5.5. Connection Class Specific Services	29
3.6. MOTOR DATA OBJECT	30
3.6.1. Motor Data Object Class Attributes	30
3.6.2. Motor Data Object Instance Attributes	30
3.6.3. Motor Data Object Common Services	30
3.6.4. Motor Data Object Specific Services	30

3.7. CONTROL SUPERVISOR OBJECT	31
3.7.1. Control Supervisor Object Class Attributes	31
3.7.2. Control Supervisor Object Instance Attributes	32
3.7.3. Control Supervisor Object Common Services	33
3.7.4. Control Supervisor Object Specific Services	33
3.7.5. Run/Stop Event Matrix	33
3.7.6. Control Supervisor State Transition Diagram	33
3.8. AC/DC DRIVE OBJECT	34
3.8.1. AC/DC Drive Object Class Attributes	34
3.8.2. AC/DC Drive Object Instance Attributes	35
3.8.3. AC/DC Drive Object Common Services	35
3.8.4. AC/DC Drive Object Specific Services	35
3.9. VENDER SPECIFIC DEVICE PROFILES	36
3.10. ABOUT EDS-FILE	36

1. Introduction

Thank you for purchasing the DeviceNet option “DEV002Z” for the VF-AS1/PS1. Before using the DeviceNet option, please familiarize yourself with the product and be sure to thoroughly read the instructions and precautions contained in this manual.

In addition, please make sure that this manual and “Instruction Manual” is delivered to the end user, and keep this function manual in a safe place for future reference or drive/interface inspection.

This manual describes the supported functions for the “DEV002Z”.

In conjunction with this manual, the following manuals are supplied by Toshiba, and are essential both for ensuring a safe, reliable system installation as well as for realizing the full potential of the “DEV002Z”:

- TOSVERT VF-AS1 Instruction Manual.....E6581301
- TOSVERT VF-PS1 Instruction Manual.....E6581386
- DEV002Z Instruction Manual (Installation, Wiring, etc.).....E6581295

2. Connection Information

2.1. Connection Sizes

Connection Instance	Produced	Consumed
I/O Messaging	4, 8, or 12 bytes	4, 8, or 12 bytes
Explicit Messaging	55 bytes	55 bytes

Notes

- For the Polled I/O connection, if the actual consumed data size is less than the connection instance's consumed_connection_size attribute, the consumed data will be ignored, but the connection will otherwise produce normally. If the actual consumed data size is larger than the connection instance's consumed_connection_size attribute, the consumed data will be ignored and the connection will not produce.
- For the Explicit Messaging connection, this is the maximum message length: shorter messages are also acceptable.

2.2. Exterior overview

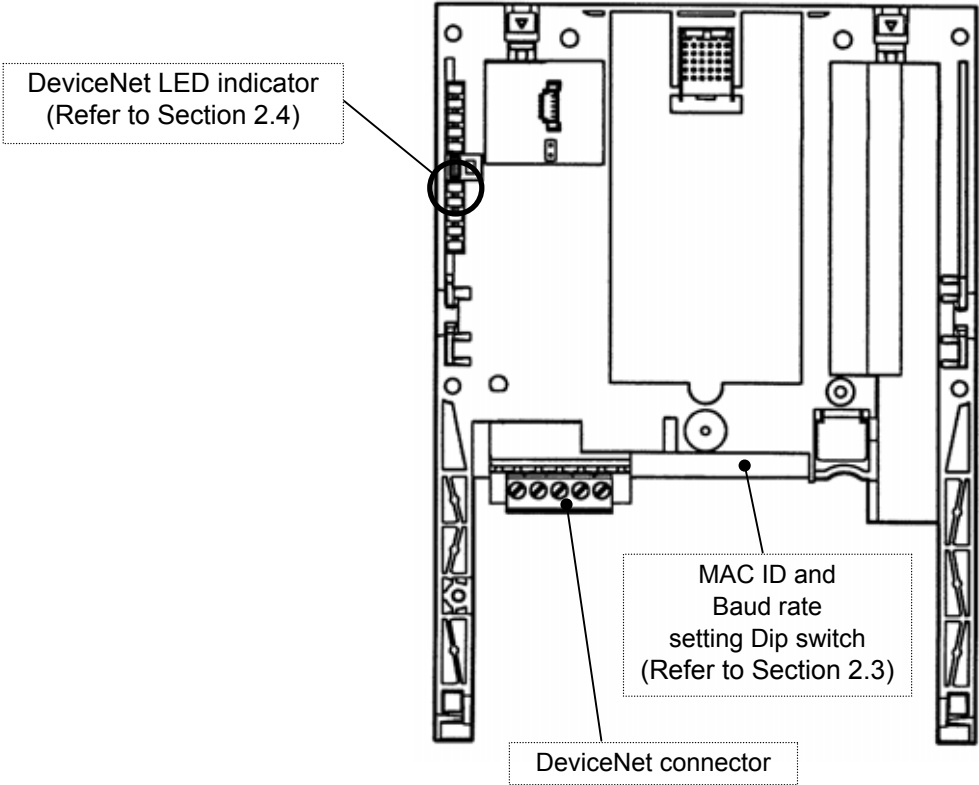

2.3. Setting a MAC ID number and a network baud rate

Configure MAC ID and network baud rate by the Dip switch on the DeviceNet option.



<Default setting>
 MAC ID = 1
 Baud rate = 125kbps

- MAC ID configuration
 The MAC ID must be unique and not match any other device on the network.

SW ID	3	4	5	6	7	8
	MAC ID					
0	OFF	OFF	OFF	OFF	OFF	OFF
1	OFF	OFF	OFF	OFF	OFF	ON
2	OFF	OFF	OFF	OFF	ON	OFF
3	OFF	OFF	OFF	OFF	ON	ON
4	OFF	OFF	OFF	ON	OFF	OFF
5	OFF	OFF	OFF	ON	OFF	ON
6	OFF	OFF	OFF	ON	ON	OFF
7	OFF	OFF	OFF	ON	ON	ON
8	OFF	OFF	ON	OFF	OFF	OFF
9	OFF	OFF	ON	OFF	OFF	ON
10	OFF	OFF	ON	OFF	ON	OFF
11	OFF	OFF	ON	OFF	ON	ON
12	OFF	OFF	ON	ON	OFF	OFF
13	OFF	OFF	ON	ON	OFF	ON
14	OFF	OFF	ON	ON	ON	OFF
15	OFF	OFF	ON	ON	ON	ON
16	OFF	ON	OFF	OFF	OFF	OFF
17	OFF	ON	OFF	OFF	OFF	ON
18	OFF	ON	OFF	OFF	ON	OFF
19	OFF	ON	OFF	OFF	ON	ON
20	OFF	ON	OFF	ON	OFF	OFF
21	OFF	ON	OFF	ON	OFF	ON
22	OFF	ON	OFF	ON	ON	OFF
23	OFF	ON	OFF	ON	ON	ON
24	OFF	ON	ON	OFF	OFF	OFF
25	OFF	ON	ON	OFF	OFF	ON
26	OFF	ON	ON	OFF	ON	OFF
27	OFF	ON	ON	OFF	ON	ON
28	OFF	ON	ON	ON	OFF	OFF
29	OFF	ON	ON	ON	OFF	ON
30	OFF	ON	ON	ON	ON	OFF
31	OFF	ON	ON	ON	ON	ON

SW ID	3	4	5	6	7	8
	MAC ID					
32	ON	OFF	OFF	OFF	OFF	OFF
33	ON	OFF	OFF	OFF	OFF	ON
34	ON	OFF	OFF	OFF	ON	OFF
35	ON	OFF	OFF	OFF	ON	ON
36	ON	OFF	OFF	ON	OFF	OFF
37	ON	OFF	OFF	ON	OFF	ON
38	ON	OFF	OFF	ON	ON	OFF
39	ON	OFF	OFF	ON	ON	ON
40	ON	OFF	ON	OFF	OFF	OFF
41	ON	OFF	ON	OFF	OFF	ON
42	ON	OFF	ON	OFF	ON	OFF
43	ON	OFF	ON	OFF	ON	ON
44	ON	OFF	ON	ON	OFF	OFF
45	ON	OFF	ON	ON	OFF	ON
46	ON	OFF	ON	ON	ON	OFF
47	ON	OFF	ON	ON	ON	ON
48	ON	ON	OFF	OFF	OFF	OFF
49	ON	ON	OFF	OFF	OFF	ON
50	ON	ON	OFF	OFF	ON	OFF
51	ON	ON	OFF	OFF	ON	ON
52	ON	ON	OFF	ON	OFF	OFF
53	ON	ON	OFF	ON	OFF	ON
54	ON	ON	OFF	ON	ON	OFF
55	ON	ON	OFF	ON	ON	ON
56	ON	ON	ON	OFF	OFF	OFF
57	ON	ON	ON	OFF	OFF	ON
58	ON	ON	ON	OFF	ON	OFF
59	ON	ON	ON	OFF	ON	ON
60	ON	ON	ON	ON	OFF	OFF
61	ON	ON	ON	ON	OFF	ON
62	ON	ON	ON	ON	ON	OFF
63	ON	ON	ON	ON	ON	ON

- Baud rate configuration

SW kbps	1	2
	Baud rate	
125	OFF	OFF
250	OFF	ON
500	ON	OFF

Maximum length of main line
 500m (1640 ft.)
 250m (820 ft.)
 100m (328 ft.)

2.4. DeviceNet LED indicator

The DEV002Z option has a two-color (red and green) LED as a means of indicating the MNS (module/network status), which works basically in accordance with DeviceNet specifications.

LED	Status	Item displayed
Off	Not Powered/Not On-line	Device is not on-line. - The DEV002Z has not completed the Dup_MAC_ID test yet. - The DEV002Z may not be powered.
Lights green.	Device Operational AND On-line, Connected	The DEV002Z is operating in a normal condition and the DEV002Z is on-line with connections in the established state.
Flashes green.	Device Operational AND On-line, Not Connected or Device On-line AND Device needs commissioning	The DEV002Z is operating in a normal condition and the DEV002Z is on-line with no connections in the established state. - The DEV002Z has passed the Dup_MAC_ID test, is on-line, but has no established connections to other nodes. - Configuration missing, incomplete or incorrect.
Flashes red.	Minor Fault and/or Connection Time-Out	Recoverable fault and/or one or more I/O Connections are in the Timed-Out state.
Lights red.	Critical Fault or Critical Link Failure	The DEV002Z has an unrecoverable fault; may need replacing. Failed communication device. The DEV002Z has detected an error that has rendered it incapable of communicating on the network (Duplicate MAC ID, or Bus-off).
Flashes red and green alternately.	Communication Faulted and Received an Identify Comm Fault Request - Long Protocol	A specific Communication Faulted device. The DEV002Z has detected a Network Access error and is in the Communication Faulted state. The DEV002Z has subsequently received and accepted an Identify Communication Faulted Request - Long Protocol message.

2.5. Communications-related parameters

In a network, VF-AS1/PS1 (DEV002Z) serves as a DeviceNet slave device. The DEV002Z configuration is set by the following parameters.

The supported parameters for each drive and their allowable adjustment ranges are defined in the appropriate Electronic Data Sheet (EDS) files. EDS files can be downloaded via the internet from

http://www.inverter.co.jp/product/inv/vfas1/dev/index_i.htm

Parameter	Function	Adjustment range	Default setting
<i>F830</i> *	Communication option setting 1 〔 Assembly Object 〕	0: Instance 20/70 1: Instance 21/71 2: Instance 100/150 3: Instance 101/151 4: Instance 102/152	0
<i>F831</i> - <i>F846</i>	Communication option setting 2 - 13	Refer to section 3.4.5.6.	-
<i>F851</i>	Inverter operation at the communications loss action (Network wire breaks)	0: Stop and Communication release 1: None 2: Deceleration stop 3: Coast stop 4: Emergency stop 5: Preset speed operation command (Operating at the preset speed operation frequency set with <i>F852</i>)	0
<i>F852</i>	Preset speed operation selection	0: None 1 to 15:Preset speed	0
<i>F853</i>	Monitoring of communication device station address	Displays the MAC ID number assigned using the DIP switch. 0 to 63	1
<i>F854</i>	Monitoring of communications device's baud rate	Displays the network communication speed set with the DIP switch. 0: 125kbps 1: 250kbps 2: 500kbps	0
<i>F899</i>	Network option reset setting	0: None 1: Resetting the DEV002Z and the inverter	0

* When the parameter is changed, the power must be cycled (or set *F899* to 1) to the VF-AS1/PS1 for the changes to take effect.

** When *F70d* or *C70d* is set to "Communication Input", VF-AS1/PS1 drives without Net Ref (Frequency link) or Net Ctrl (command link) at each Instance.

3. Object Specifications

This section contains the object specifications for all DeviceNet objects currently supported by the “DEV002Z”. Table 1 outlines those objects covered:

Class Code	Object Class	Page
0x01	Identity Object	9
0x02	Message Router Object	10
0x03	DeviceNet Object	11
0x04	Assembly Object	12
0x05	Connection Object	27
0x28	Motor Data Object	30
0x29	Control Supervisor Object	31
0x2A	AC/DC Drive Object	34
0x64	Parameter Object	36

Table 1: Supported Objects

For definitions of all data types referred to in these object specifications, refer to the ODVA DeviceNet Specifications. In general, however, the following are some of the most prevalent types:

SINT Signed 8-bit integer value
 USINT Unsigned 8-bit integer value
 BYTE..... Bit string - 8-bits
 INT Signed 16-bit integer value
 UINT..... Unsigned 16-bit integer value
 WORD..... Bit string - 16-bits
 UDINT Unsigned 32-bit integer value

3.1. Identity Object

Class code 0x01. This object provides identification of and general information about the device.

3.1.1. Identity Object Class Attributes

Attribute ID	Name	Data Type	Access Rules	Description	Default Value
1	Revision	UINT	Get	Revision of this object	1
2	Max instance	UINT	Get	Maximum instance number of an object currently created in this class level of the device	1

3.1.2. Identity Object Instance Attributes

Attribute ID	Name	Data Type	Access Rules	Description	Default Value
1	Vendor ID	UINT	Get	Identification of vendor by number	377
2	Device type	UINT	Get	Indication of general type of product	2 (AC Drive)
3	Product code	UINT	Get	Identification of a particular product of an individual vendor	(2134) *
4	Revision (Major)	USINT (ARRAY)	Get	Revision of the item the Identity Object represents	(1) **
	Revision (Minor)	USINT (ARRAY)	Get		(34) **
5	Status (bits supported)	WORD	Get	Summary status of device	-
6	Serial number	UDINT	Get	Serial number of device	-
7	Product name	SHORT_STRING	Get	Human-readable identification	"DEV002Z"
8	State	USINT	Get	Present state of the device 0 = Non-existent 1 = Device Self Testing 2 = Standby 3 = Operational 4 = Major Recoverable Fault 5 = Major Unrecoverable Fault	-
10	Heartbeat Interval	USINT	Get/Set	The nominal interval between heartbeat messages in seconds.	0

* Triple figures are the same value as VF-AS1/PS1 software version under Product code.

** Revision (Major) is the same value as the single figure on the VF-AS1/PS1 software version.

Revision (Major) is the same value as double figures under the VF-AS1/PS1 software version.

3.1.3. Identity Object Common Services

Service Code	Service Name	Supported		Description of Service
		Class	Instance	
0x05	Reset	N/A	Yes	Invokes the Reset service for the device
0x0E	Get_Attribute_Single	Yes	Yes	Returns the contents of the specified attribute.
0x10	Set_Attribute_Single	N/A	Yes	Modifies the value of the specified attribute.

3.1.4. Identity Object Specific Services

The Identity Object provides no object specific services.

3.2. Message Router

Class code 0x02. The Message Router Object provides a messaging connection point through which a Client may address a service to any object class or instance residing in the DeviceNet interface unit.

3.2.1. Message Router Class Attributes

Attribute ID	Name	Data Type	Access Rules	Description	Default Value
1	Revision	UINT	Get	Revision of this object	1
2	Max instance	UINT	Get	Maximum instance number of an object currently created in this class level of the device	1

3.2.2. Message Router Instance Attributes

Attribute ID	Name	Data Type	Access Rules	Description	Default Value
1	Object List	USINT (ARRAY)	Get	A list of supported objects	-
2	Number Available	UINT	Get	Maximum number of connections supported	1
3	Number Active	UINT	Get	Number of connections currently used by system components	1
4	Active Connections	UINT (ARRAY)	Get	A list of the connection IDs of the currently active connections	1

3.2.3. Message Router Common Services

Service Code	Service Name	Supported		Description of Service
		Class	Instance	
0x0E	Get_Attribute_Single	Yes	Yes	Returns the contents of the specified attribute.

3.2.4. Message Router Specific Services

The Message Router provides no object specific services.

3.3. DeviceNet Object

Class Code 0x03. The DeviceNet Object provides for the configuration and status of a DeviceNet port.

3.3.1. DeviceNet Object Class Attributes

Attribute ID	Name	Data Type	Access Rules	Description	Default Value
1	Revision	UINT	Get	Revision of this object.	2
2	Max instance	UINT	Get	Maximum instance number of an object currently created in this class level of the device	1

3.3.2. DeviceNet Object Instance Attributes

Attribute ID	Name	Data Type	Access Rules	Description	Default Value
1	MAC ID	USINT	Get	Node address	1 *
2	Baud Rate	USINT	Get	Baud rate 0 = 125kbps 1 = 250kbps 2 = 500kbs	0*
3	Bus-off Interrupt	BOOL	Get/Set	Bus-Off Interrupt	0
4	Bus-off counter	USINT	Get/Set	Number of times CAN went to the bus-off state	0
5	Allocation information (Allocation Choice Byte)	BYTE	Get	Master/Slave allocation state	-
	Allocation information (Master's MAC ID)	USINT	Get	MAC ID of Master (from Allocate)	-
6	MAC ID Switch Changed	BOOL	Get	The Node Address Switch(es) have changed since last power-up/reset.	0
7	Baud Rate Switch Changed	BOOL	Get	The Baud Rate Switch(es) have changed since last power-up/reset.	0
8	MAC ID Switch Value	USINT	Get	Actual value of Node Address switch(es)	1*
9	Baud Rate Switch Value	USINT	Get	Actual value of Baud Rate switch(es)	0*

* The MAC ID and Baud Rate are settable by DIP SW.

3.3.3. DeviceNet Object Common Services

Service Code	Service Name	Supported		Description of Service
		Class	Instance	
0x0E	Get_Attribute_Single	Yes	Yes	Returns the contents of the specified attribute.
0x10	Set_Attribute_Single	N/A	Yes	Modifies the value of the specified attribute.

3.3.4. DeviceNet Object Specific Services

Service Code	Service Name	Supported		Description of Service
		Class	Instance	
0x4B	Allocate_Master/Slave_Connection_Set	N/A	Yes	Requests the use of the Predefined Master/Slave Connection Set.
0x4C	Release_Group_2_Identifier_Set	N/A	Yes	Indicates that the specified connections within the <i>Predefined Master/Slave Connection Set</i> are no longer desired. These connections are to be released (deleted).

3.4. Assembly Object

Class code 0x04. The Assembly Object binds attributes of multiple objects, which allows data to or from each object to be sent or received over a single connection.

3.4.1. Assembly Object Class Attributes

Attribute ID	Name	Data Type	Access Rules	Description	Default Value
1	Revision	UINT	Get	Revision of this object.	2
2	Max instance	UINT	Get	Maximum instance number of an object currently created in this class level of the device	10

3.4.2. Assembly Object Instance Attributes

Attribute ID	Name	Data Type	Access Rules	Description	Default Value
3	Data	BYTE (ARRAY)	Get/Set	The data contained in the assembly object. (Refer to section 3.4.5.)	-

3.4.3. Assembly Object Common Services

Service Code	Service Name	Supported		Description of Service
		Class	Instance	
0x0E	Get_Attribute_Single	Yes	Yes	Returns the contents of the specified attribute.
0x10	Set_Attribute_Single	N/A	Yes	Modifies the value of the specified attribute.

3.4.4. Assembly Object Specific Services

The Assembly Object for static assemblies provides no object specific services.

3.4.5. Assembly Instance Details (*F830*)3.4.5.1. Instance 20/70 - DeviceNet Standard (4 bytes, parameter *F830* = 0)

Byte	Bit 7	Bit 6	Bit 5	Bit 4	Bit 3	Bit 2	Bit 1	Bit 0
0	-	-	-	-	-	Fault reset	-	Run forward
1	-							
2	Drive Reference Speed min^{-1} (Low byte) *							
3	Drive Reference Speed min^{-1} (High byte) *							

Fig. 1 Output Instance 20 Layout

Byte	Bit 7	Bit 6	Bit 5	Bit 4	Bit 3	Bit 2	Bit 1	Bit 0
0	-	-	-	-	-	Running Forward	-	Faulted/tripped
1	-							
2	Drive Actual Speed min^{-1} (Low byte)							
3	Drive Actual Speed min^{-1} (High byte)							

Fig. 2 Input Instance 70 Layout

Examples of Instance 20/70

Stop

Instance	Byte	15	14	13	12	11	10	9	8	7	6	5	4	3	2	1	0	Hex.
Output Instance 20	1, 0	0	0	0	0	0	0	0	0	0	0	0	0	0	0	0	0	0x0000
	3, 2	-	-	-	-	-	-	-	-	-	-	-	-	-	-	-	-	-
Input Instance 70	1, 0	0	0	0	0	0	0	0	0	0	0	0	0	0	0	0	0	0x0000
	3, 2	0	0	0	0	0	0	0	0	0	0	0	0	0	0	0	0	0x0000

Forward running 1800 min^{-1}

Instance	Byte	15	14	13	12	11	10	9	8	7	6	5	4	3	2	1	0	Hex.
Output Instance 20	1, 0	0	0	0	0	0	0	0	0	0	0	0	0	0	0	0	1	0x0001
	3, 2	0	0	0	0	0	1	1	1	0	0	0	0	1	0	0	0	0x0708
Input Instance 70	1, 0	0	0	0	0	0	0	0	0	0	0	0	0	0	1	0	0	0x0004
	3, 2	0	0	0	0	0	1	1	1	0	0	0	0	1	0	0	0	0x0708

Fault reset **

Instance	Byte	15	14	13	12	11	10	9	8	7	6	5	4	3	2	1	0	Hex.
Output Instance 20	1, 0	0	0	0	0	0	0	0	0	0	0	0	0	0	1	0	0	0x0004
	3, 2	-	-	-	-	-	-	-	-	-	-	-	-	-	-	-	-	-

* Drive Reference Speed is set up number of rotations by the hexadecimal number.
For example, when "Frequency reference" is set up to 1800min^{-1} :
1800 = 0x0708 (Hex.)

** Fault reset works only 1 time when 0 -> 1.

3.4.5.2. Instance 21/71 - DeviceNet Standard (4 bytes, parameter $F830 = 1$)

Byte	Bit 7	Bit 6	Bit 5	Bit 4	Bit 3	Bit 2	Bit 1	Bit 0
0	-	Net Ref *	Net Ctrl *	-	-	Fault reset	Run reverse	Run forward
1	-							
2	Drive Reference Speed min^{-1} (Low byte)							
3	Drive Reference Speed min^{-1} (High byte)							

Fig. 3 Output Instance 21 Layout

Byte	Bit 7	Bit 6	Bit 5	Bit 4	Bit 3	Bit 2	Bit 1	Bit 0
0	At reference **	Ref from Net **	Ctrl from Net **	Ready	Running Reverse	Running Forward	Warning	Faulted/tripped
1	Drive Status ***							
2	Drive Reference Speed min^{-1} (Low byte)							
3	Drive Reference Speed min^{-1} (High byte)							

Fig. 4 Input Instance 71 Layout

* Bit 5 and 6 of the instance 21 byte 0 are defined as follows.

Bit 5 (Net Ctrl)..... When "1" is set, bits 0 (Run forward) and 1 (Run reverse) of byte 0 are enabled. When "0" is set, Run/Stop is according to setup of the parameter $L70d$.

Bit 6 (Net Ref)..... When "1" is set, bytes 2 and 3 are enabled. When "0" is set, Drive Reference Speed is according to setup of the parameter $F70d$.

** Bit 5, 6, and 7 of the instance 71 byte 0 are defined as follows.

Bit 5 (Ctrl from Net)..... When RUN/STOP command from DeviceNet is enabled, "1" is set.

Bit 6 (Ref from Net)..... When frequency command from DeviceNet is enabled, "1" is set.

Bit 7 (At reference) When output frequency becomes the same as frequency command, "1" is set.

*** Drive Status is same as the Control Supervisor class State attribute (refer to section 3.7.2).

- 1 (= BN: 00000001): Startup
- 2 (= BN: 00000010): Not Ready
- 3 (= BN: 00000011): Ready
- 4 (= BN: 00000100): Enabled
- 5 (= BN: 00000101): Stopping
- 6 (= BN: 00000110): Fault Stop
- 7 (= BN: 00000111): Faulted

Examples of Instance 21/71

Stop

Instance	Byte	15	14	13	12	11	10	9	8	7	6	5	4	3	2	1	0	Hex.
Output Instance 21	1,0	0	0	0	0	0	0	0	0	0	0	0	0	0	0	0	0	0x0000
	3,2	-	-	-	-	-	-	-	-	-	-	-	-	-	-	-	-	-
Input Instance 71	1,0	0	0	0	0	0	0	1	1	0	0	0	1	0	0	0	0	0x0310
	3,2	0	0	0	0	0	0	0	0	0	0	0	0	0	0	0	0	0x0000

Forward running 1800min-1

Instance	Byte	15	14	13	12	11	10	9	8	7	6	5	4	3	2	1	0	Hex.
Output Instance 21	1,0	0	0	0	0	0	0	0	0	0	1	1	0	0	0	0	1	0x0061
	3,2	0	0	0	0	0	1	1	1	0	0	0	0	1	0	0	0	0x0708
Input Instance 71	1,0	0	0	0	0	0	1	0	0	1	1	1	1	0	1	1	0	0x04F6
	3,2	0	0	0	0	0	1	1	1	0	0	0	0	1	0	0	0	0x0708

Reverse running 1800min-1

Instance	Byte	15	14	13	12	11	10	9	8	7	6	5	4	3	2	1	0	Hex.
Output Instance 21	1,0	0	0	0	0	0	0	0	0	0	1	1	0	0	0	1	0	0x0062
	3,2	0	0	0	0	0	1	1	1	0	0	0	0	1	0	0	0	0x0708
Input Instance 71	1,0	0	0	0	0	0	1	0	0	1	1	1	1	1	0	1	0	0x04FA
	3,2	0	0	0	0	0	1	1	1	0	0	0	0	1	0	0	0	0x0708

Fault reset *

Instance	Byte	15	14	13	12	11	10	9	8	7	6	5	4	3	2	1	0	Hex.
Output Instance 21	1,0	0	0	0	0	0	0	0	0	0	0	0	0	0	1	0	0	0x0004
	3,2	-	-	-	-	-	-	-	-	-	-	-	-	-	-	-	-	-

* Fault reset works only 1 time when 0 -> 1.

3.4.5.3. Instance 100/150 - Toshiba Specific (4 bytes, parameter $F830 = 2$)

Byte	Bit 7	Bit 6	Bit 5	Bit 4	Bit 3	Bit 2	Bit 1	Bit 0
0	DC braking	ACC1/ ACC2	PI off	THR2	Preset Speed4	Preset Speed3	Preset Speed2	Preset Speed1
1	Command link *	Frequency link *	Reset trip	Emergency stop	Free run (ST)	Run/stop	Forward/ Reverse	Jog
2	Drive Reference Speed Hz (Low byte) **							
3	Drive Reference Speed Hz (High byte) **							

Fig. 5 Output Instance 100 Layout

Byte	Bit 7	Bit 6	Bit 5	Bit 4	Bit 3	Bit 2	Bit 1	Bit 0
0	DC braking	ACC2	PI	THR 2 (VF2+tH2)	-	ALARM (fc91)	EMG	FL
1	-	READY without ST/RUN	READY with ST/ RUN	Emergency stop	Free run (ST)	Run/Stop	Forward / Reverse	Jog
2	Drive Actual Speed Hz (Low byte)							
3	Drive Actual Speed Hz (High byte)							

Fig. 6 Input Instance 150 Layout

* Bit 14 and 15 of the instance 100 byte 0 are defined as follows.

Bit 15 (Command link).... When "0" is set, the other command does not work except bit 12 and 13, Run/Stop is according to setup of the parameter CND .

Bit 14 (Frequency link) ... When "1" is set, bytes 2 and 3 are enabled. When "0" is set, Drive Reference Speed is according to setup of the parameter FND .

** Drive Reference Speed is set up by 0.01Hz unit and the hexadecimal number.

For example, when "Frequency reference" is set up to 60Hz, since the minimum unit is 0.01Hz, $60 / 0.01 = 6000 = 0x1770$ (Hex.)

Examples of Instance 100/150

Stop

Instance	Byte	15	14	13	12	11	10	9	8	7	6	5	4	3	2	1	0	Hex.
Output Instance 100	1, 0	0	0	0	0	0	0	0	0	0	0	0	0	0	0	0	0	0x0000
	3, 2	-	-	-	-	-	-	-	-	-	-	-	-	-	-	-	-	-
Input Instance 150	1, 0	0	1	0	0	1	0	0	0	0	0	0	0	0	0	0	0	0x4800
	3, 2	0	0	0	0	0	0	0	0	0	0	0	0	0	0	0	0	0x0000

Forward running 60Hz

Instance	Byte	15	14	13	12	11	10	9	8	7	6	5	4	3	2	1	0	Hex.
Output Instance 100	1, 0	1	1	0	0	0	1	0	0	0	0	0	0	0	0	0	0	0xC400
	3, 2	0	0	0	1	0	1	1	1	0	1	1	1	0	0	0	0	0x1770
Input Instance 150	1, 0	0	1	1	0	0	1	0	0	0	0	0	0	0	0	0	0	0x6400
	3, 2	0	0	0	1	0	1	1	1	0	1	1	1	0	0	0	0	0x1770

Reverse running 60Hz

Instance	Byte	15	14	13	12	11	10	9	8	7	6	5	4	3	2	1	0	Hex.
Output Instance 100	1, 0	1	1	0	0	0	1	1	0	0	0	0	0	0	0	0	0	0xC600
	3, 2	0	0	0	1	0	1	1	1	0	1	1	1	0	0	0	0	0x1770
Input Instance 150	1, 0	0	1	1	0	0	1	1	0	0	0	0	0	0	0	0	0	0x6600
	3, 2	0	0	0	1	0	1	1	1	0	1	1	1	0	0	0	0	0x1770

Preset speed 1 with forward running (ζ_{r1})

Instance	Byte	15	14	13	12	11	10	9	8	7	6	5	4	3	2	1	0	Hex.
Output Instance 100	1, 0	1	0	0	0	0	1	0	0	0	0	0	0	0	0	0	1	0x8401
	3, 2	-	-	-	-	-	-	-	-	-	-	-	-	-	-	-	-	-
Input Instance 150 (ζ_{r1} is set 5Hz.)	1, 0	0	1	1	0	0	1	0	0	0	0	0	0	0	0	0	0	0x6400
	3, 2	0	0	0	0	0	0	0	1	1	1	1	1	0	1	0	0	0x01F4

Fault reset *

Instance	Byte	15	14	13	12	11	10	9	8	7	6	5	4	3	2	1	0	Hex.
Output Instance 100	1, 0	0	0	1	0	0	0	0	0	0	0	0	0	0	0	0	0	0x2000
	3, 2	-	-	-	-	-	-	-	-	-	-	-	-	-	-	-	-	-

About the other command, refer to section 3.4.6.1.

* Fault reset works only 1 time when 0 -> 1.

3.4.5.4. Instance 101/151 - Toshiba Specific (8 bytes, parameter $F830 = 3$)

Byte	Bit 7	Bit 6	Bit 5	Bit 4	Bit 3	Bit 2	Bit 1	Bit 0
0	-	Net Ref	Net Ctrl	-	-	Fault reset	Run reverse	Run forward
1	-							
2	Drive Reference Speed min^{-1} (Low byte)							
3	Drive Reference Speed min^{-1} (High byte)							
4	Index (Low byte)							
5	Write	Index (High byte)						
6	Data (Low byte)							
7	Data (High byte)							

Fig. 7 Output Instance 101 Layout

Byte	Bit 7	Bit 6	Bit 5	Bit 4	Bit 3	Bit 2	Bit 1	Bit 0
0	At reference	Ref from Net	Ctrl from Net	Ready	Running Reverse	Running Forward	Warning	Faulted/tripped
1	Drive Status *							
2	Drive Actual Speed min^{-1} (Low byte)							
3	Drive Actual Speed min^{-1} (High byte)							
4	Index (Low byte)							
5	Write	Error	Index (High byte)					
6	Data (Low byte)							
7	Data (High byte)							

Fig. 8 Input Instance 151 Layout

* Drive Status is same as the Control Supervisor class State attribute (refer to 3.7.2).

- 1 (= BN: 00000001): Startup
- 2 (= BN: 00000010): Not Ready
- 3 (= BN: 00000011): Ready
- 4 (= BN: 00000100): Enabled
- 5 (= BN: 00000101): Stopping
- 6 (= BN: 00000110): Fault Stop
- 7 (= BN: 00000111): Faulted

Examples of Instance 101/151

Access the inverter parameter is enabled using byte 4 to 6 of this Instance.

Set the communication number of the parameter to byte 4, 5 (Index), and the value to byte 6, 7 (Data).

In case of the monitor parameter "FE**", the value becomes "communication number - 0x7000 (same as bit14, 15 set to 0)".

Read the parameter $\text{C}00d$ (Command mode selection, communication number is 0003).

Instance	Byte	15	14	13	12	11	10	9	8	7	6	5	4	3	2	1	0	Hex.
Output Instance 101	5, 4	0	0	0	0	0	0	0	0	0	0	0	0	0	0	1	1	0x0003
	7, 6	-	-	-	-	-	-	-	-	-	-	-	-	-	-	-	-	-
Input Instance 151 ($\text{C}00d$ is set 0.)	5, 4	0	0	0	0	0	0	0	0	0	0	0	0	0	0	1	1	0x0003
	7, 6	0	0	0	0	0	0	0	0	0	0	0	0	0	0	0	0	0x0000

Read the parameter $F25B$ (Initial value of UP/DOWN frequency).

Instance	Byte	15	14	13	12	11	10	9	8	7	6	5	4	3	2	1	0	Hex.
Output Instance 101	5, 4	0	0	0	0	0	0	1	0	0	1	1	0	1	0	0	0	0x0268
	7, 6	-	-	-	-	-	-	-	-	-	-	-	-	-	-	-	-	-
Input Instance 151 ($F25B$ is set 60.0Hz.)	5, 4	0	0	0	0	0	0	1	0	0	1	1	0	1	0	0	0	0x0268
	7, 6	0	0	0	1	0	1	1	1	0	1	1	1	0	0	0	0	0x1770

Read the parameter $FE04$ (Voltage of DC bus).

Instance	Byte	15	14	13	12	11	10	9	8	7	6	5	4	3	2	1	0	Hex.
Output Instance 101	5, 4	0	0	1	1	1	1	1	0	0	0	0	0	0	1	0	0	0x3E04
	7, 6	-	-	-	-	-	-	-	-	-	-	-	-	-	-	-	-	-
Input Instance 151 ($FE04$ is 94.49%.)	5, 4	0	0	1	1	1	1	1	0	0	0	0	0	0	1	0	0	0x3E04
	7, 6	0	0	1	0	0	1	0	0	1	1	1	0	1	0	0	1	0x24E9

Write "60 (Hz)" to the parameter $Sr1$ (Preset speed 1, communication number is 0018).

Instance	Byte	15	14	13	12	11	10	9	8	7	6	5	4	3	2	1	0	Hex.
Output Instance 101	5, 4	1	0	0	0	0	0	0	0	0	0	0	1	1	0	0	0	0x8018
	7, 6	0	0	0	1	0	1	1	1	0	1	1	1	0	0	0	0	0x1770
Input Instance 151 (OK)	5, 4	1	0	0	0	0	0	0	0	0	0	0	1	1	0	0	0	0x8018
	7, 6	0	0	0	1	0	1	1	1	0	1	1	1	0	0	0	0	0x1770
Input Instance 151 (NG) (Error code *)	5, 4	1	1	0	0	0	0	0	0	0	0	0	1	1	0	0	0	0xC018
	7, 6	0	0	0	0	0	0	0	0	0	0	0	0	0	0	0	1	0x0001

About byte 0 - 3, refer to section 3.4.5.2.

* Refer to following about the error code.

1(= BN: 00000001):: Data out of range

2(= BN: 00000010):: Bad address

3(= BN: 00000011):: Read only

4(= BN: 00000100):: Stop to modify or permission error

5(= BN: 00000101):: All other

3.4.5.5. Instance 102/152 - Toshiba Specific (12 bytes, parameter $F830 = 4$)

Byte	Bit 7	Bit 6	Bit 5	Bit 4	Bit 3	Bit 2	Bit 1	Bit 0
0	<i>F831</i> Command data (Low byte)							
1	<i>F831</i> Command data (High byte)							
2	<i>F832</i> Command data (Low byte)							
3	<i>F832</i> Command data (High byte)							
4	<i>F833</i> Command data (Low byte)							
5	<i>F833</i> Command data (High byte)							
6	<i>F834</i> Command data (Low byte)							
7	<i>F834</i> Command data (High byte)							
8	<i>F835</i> Command data (Low byte)							
9	<i>F835</i> Command data (High byte)							
10	<i>F836</i> Command data (Low byte)							
11	<i>F836</i> Command data (High byte)							

Fig. 9 Output Instance 102 Layout

Byte	Bit 7	Bit 6	Bit 5	Bit 4	Bit 3	Bit 2	Bit 1	Bit 0
0	<i>F841</i> Monitor data (Low byte)							
1	<i>F841</i> Monitor data (High byte)							
2	<i>F842</i> Monitor data (Low byte)							
3	<i>F842</i> Monitor data (High byte)							
4	<i>F843</i> Monitor data (Low byte)							
5	<i>F843</i> Monitor data (High byte)							
6	<i>F844</i> Monitor data (Low byte)							
7	<i>F844</i> Monitor data (High byte)							
8	<i>F845</i> Monitor data (Low byte)							
9	<i>F845</i> Monitor data (High byte)							
10	<i>F846</i> Monitor data (Low byte)							
11	<i>F846</i> Monitor data (High byte)							

Fig. 10 Input Instance 152 Layout

3.4.5.6. How to use Instance 102/152

The purposes of instances 102/152 are adjustment by real time command transmission, and the monitor of an operation state by using cyclic communication of DeviceNet.

Example 1: Command transmitting by output Instance 102

When you want to set "0xC400" to parameter *F A 0 6*, set "1 (FA06)" to parameter *F B 3 1*.
 And Since 0 and 1 byte of the output instance 102 supports the parameter *F B 3 1*, if "0xC400" is set up here, "0xC400" will be set as *F A 0 6*.

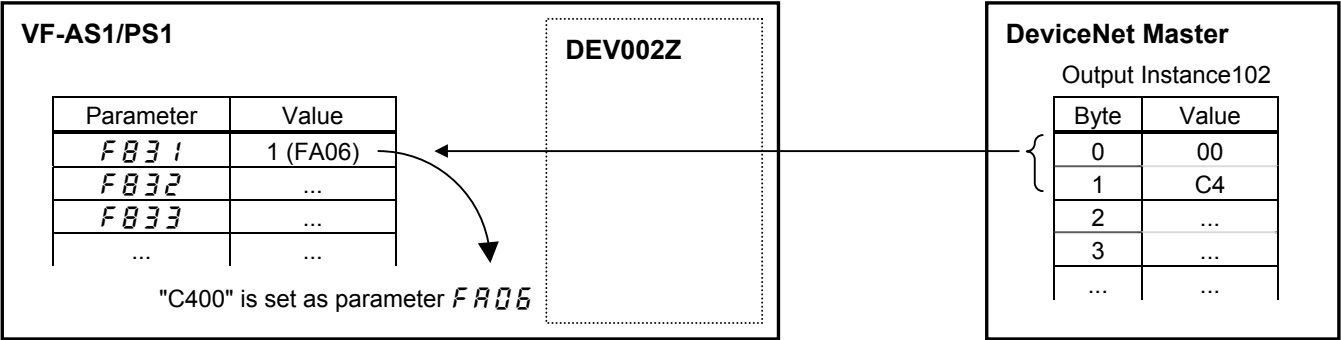

Example 2: State monitoring by the input instance 152.

When you want to monitor the output current, set "3 (FD03)" to parameter *F B 4 1*.
 The value of the parameter *F d 0 3* specified as 0 and1 byte of the input instance 152 with the parameter *F B 4 1* is inputted.

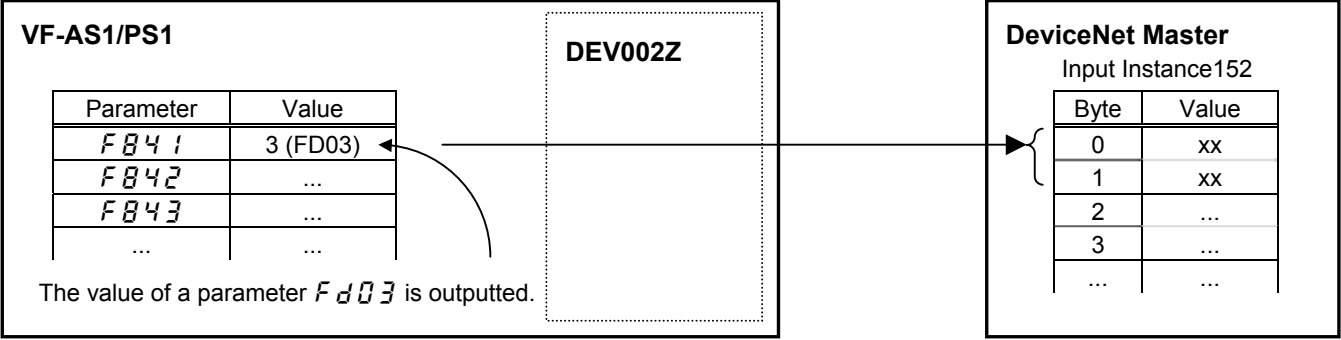

<i>F B 3 1</i> - <i>F B 3 6</i> setup value	<i>F B 4 1</i> - <i>F B 4 6</i> setup value
0: No action	0: No action
1: FA06 (ALCAN2 command 1)	1: FD01 (Inverter status 1)
2: FA23 (ALCAN2 command 2)	2: FD00 (Output frequency, 0.01Hz)
3: FA07 (ALCAN2 frequency command, 0.01Hz)	3: FD03 (Output current, 0.01%)
4: FA33 (Torque command, 0.01%)	4: FD05 (Output voltage, 0.01%)
5: FA50 (Terminal output)	5: FC91 (Inverter alarm)
6: FA51 (Analog output (FM) data from comm.)	6: FD22 (PID feedback value, 0.01Hz)
7: FA52 (Analog output (AM) data from comm.)	7: FD06 (Input terminal status)
8: F601 (Stall prevention level, %)	8: FD07 (Output terminal status)
9: F441 (Power running torque limit 1 level, 0.01%)	9: FE36 (VI/II input)
10: F443 (Regenerative braking torque limit 1 level, 0.01%)	10: FE35 (RR/S4 input)
11: F460 (Speed loop proportional gain)	11: FE37 (RX input)
12: F461 (Speed loop stabilization coefficient)	12: FD04 (Input voltage (DC detection), 0.01%)
	13: FD16 (Speed feedback (real-time value))
	14: FD18 (Torque, 0.01%)
	15: FE60 (My monitor)
	16: FE61 (My monitor)
	17: FE62 (My monitor)
	18: FE63 (My monitor)
	19: F880 (Free notes)
	20: FD29 (Input power, 0.01kW)
	21: FD30 (Output power, 0.01kW)
	22: FE14 (Cumulative operation time, 0.01=1 hour)
	23: FE40 (FM terminal output monitor)
	24: FE41 (AM terminal output monitor)

3.4.6. The outline of the parameter *F831-F836, F841-F846* setup value

The outline is indicated about the setting item of parameter *F831-F836* and *F841-F846* in Instance 102/152 of use.

Please refer to a communication functional description (VF-AS1: E6581315/VF-PS1: E6581413) for details.

3.4.6.1. FA06 (command word 1 from internal option PCB)

bit	Function	0	1	Note
0	Preset Speed1	OFF 0000, 1 - 15 0001 - 1111		Combination of 4 bits.
1	Preset Speed2			
2	Preset Speed3			
3	Preset Speed4			
4	THR1/2	Motor 1 (THR1)	Motor 2 (THR2)	THR1: <i>THR</i> THR2: <i>F173</i>
5	PI off	Normal	PI off	-
6	ACC1/ACC2	ACC 1 (AD1)	ACC 2 (AD2)	AD1: <i>ACC, DEC</i> AD2: <i>F500, F501</i>
7	DC braking	OFF	DC braking	-
8	Jog	OFF	JOG RUN	-
9	Fw/Reverse	Fw.	Rev.	-
10	Run/stop	STOP	RUN	-
11	Free run (ST)		Free run	-
12	Emergency stop	OFF	EMG./ Stop	Always enable
13	Reset trip	OFF	Reset	-
14	Frequency link	OFF	Priority	Enable in spite of the parameter <i>F80d</i>
15	Command link	OFF	Priority	Enable in spite of the parameter <i>C80d</i>

3.4.6.2. FA23 (command word 2 from internal option PCB)

bit	Function	0	1	Note
0	Speed/Torque	Speed Ctrl.	Torque Ctrl.	-
1	Clear kwh	OFF	Clear	Clear the value of <i>FE76, FE77</i>
2	(Reserved)	-	-	-
3 *	Brake Close (BC)	Normal	Forced Close	-
4 *	Pre magnetic	Normal	ON	-
5 *	Brake Open (B)	Brake Close	Brake Open	-
6 *	Brake Answer (BA)	Brake Close	Brake Open	-
7	Fast Stop	Normal	ON	-
8	ACC1/ACC2	00: Acc. / Dec. 1 01: Acc. / Dec. 2 10: Acc. / Dec. 3 * 11: Acc. / Dec. 4 *		Combination of 2 bits. AD1: <i>ACC, DEC</i> AD2: <i>F500, F501</i> AD3: <i>F510, F511</i> * AD3: <i>F514, F515</i> *
9	ACC3/ACC4 *			
10	THR 1/2			
11	THR 3/4 *			
12 *	Torque Limit 1/2	00: Torque limit 1 01: Torque limit 2 10: Torque limit 3 11: Torque limit 4		Combination of 2 bits.
13 *	Torque Limit 3/4			
14 *	Speed Gain 1/2	Gain 1	Gain 2	Gain 1: <i>F460, F461</i> Gain 2: <i>F462, F463</i>
15	(Reserved)	-	-	-

* These functions are reserved in VF-PS1.

3.4.6.3. FA07 (frequency reference from internal option PCB)

Frequency reference is set up by 0.01Hz unit and the hexadecimal number.

For example, when "Frequency reference" is set up to 80Hz, since the minimum unit is 0.01Hz,
 $80 / 0.01 = 8000 = 0x1F40$ (Hex.)

3.4.6.4. FA33 (torque reference from internal option PCB)

Torque reference is set up by 0.01% unit and the hexadecimal number.

For example, when "torque reference" is set up to 50%, since the minimum unit is 0.01%,
 $50 / 0.01 = 5000 = 0x1388$ (Hex.)

3.4.6.5. FA50 (Terminal output data from comm.)

By setting up the data of the bit 0 - 6 of terminal output data (FA50) from communication, setting data (0 or 1) can be outputted to the output terminal.

Please select the functional number 92 - 105 as the selection (*F 130 - F 138, F 158, F 159*) of the output terminal function before using it.

bit	Output TB function name	0	1
0	Communication data 1 (Output TB select No.: 92, 93)	OFF	ON
1	Communication data 2 (Output TB select No.: 94, 95)		
2	Communication data 3 (Output TB select No.: 96, 97)		
3	Communication data 4 (Output TB select No.: 98, 99)		
4	Communication data 5 (Output TB select No.: 100, 101)		
5	Communication data 6 (Output TB select No.: 102, 103)		
6	Communication data 7 (Output TB select No.: 104, 105)		
7	-	-	-

3.4.6.6. FA51 (Analog output (FM) data from comm.)

The data set as the parameter FA51 can output to FM terminal.

The data adjustment range is 0 - 2047 (resolution: 11 bits).

Please select 31 (analog output for communication) as FM terminal meter selection parameter (*F 154*) before using it.

Please refer to "Meter setting and adjustment" Section of the VF-AS1/PS1 instruction manual for details.

3.4.6.7. FA52 (Analog output (AM) data from comm.)

The data set as the parameter FA52 can output to AM terminal.

The data adjustment range is 0 - 2047 (resolution: 11 bits).

Please choose 31 (analog output for communication) as AM terminal meter selection parameter (*A 154*) before using it.

Please refer to "Meter setting and adjustment" Section of the VF-AS1/PS1 instruction manual for details.

3.4.6.8. FD01 (Inverter status (real time))

bit	Function	0	1	Note
0	FL	No output	Under output	-
1	EMG	No fault	Under fault	The <i>r t r y</i> status and the trip retention status are also regarded as tripped statuses.
2	ALARM	No alarm	Under alarm	-
3	(Reserved)	-	-	-
4	tHr2(VF2+tH2)	Motor 1 (THR1)	Motor 2 (THR2)	THR1: <i>t H r</i> THR2: <i>F 1 7 3</i>
5	PI	PI enable	PI off	-
6	ACC1/ACC2	Acc./Dec. 1 (AD1)	Acc./Dec. 2 (AD2)	AD1: <i>A C C, d E C</i> AD2: <i>F 5 0 0, F 5 0 1</i>
7	DC braking	OFF	DC braking	-
8	Jog	OFF	JOG RUN	-
9	Fw/Reverse	Fwd. RUN	Rev. RUN	-
10	Run/stop	STOP	RUN	-
11	Free run (ST)	ST=ON	ST=OFF	-
12	Emergency stop	No EMG. Stop	Under EMG. Stop	-
13	READY with ST/RUN			ST = ON and RUN = ON in addition to "ready for operation"*
14	READY without ST/RUN			-
15**	Local/Remote	Remote	Local	-

* Ready for operation: Initialization completed, not a stop due to a failure, no alarm issued, not *n O F F*, not a forced stop due to *L L*, not a forced stop due to a momentary power failure.

** This function is reserved in VF-AS1.

3.4.6.9. FD00 (Output frequency (real time))

The current output frequency is read into 0.01Hz of units and by the hexadecimal number. For example, when the output frequency is 80Hz, 0x1F40 (hexadecimal number) are read.

Since the minimum unit is 0.01%,
 $0x1F40 \text{ (Hex.)} = 8000 \text{ (Dec.)} * 0.01 = 80 \text{ (Hz)}$

Also about the following parameters, these are the same as this.

- FD22 (Feedback value of PID (real time)) Unit: 0.01Hz
- FD16 (PG feedback or Estimated speed (real time))..... Unit: 0.01Hz
- FD29 (Input power (real time))..... Unit: 0.01kW
- FD30 (Output power (real time))..... Unit: 0.01kW

3.4.6.10. FD03 (Output current (real time))

The output current is read into 0.01% of units and by the hexadecimal number. For example, when the output current of the rated current 4.8A inverter is 50% (2.4A), 0x1388 (hexadecimal number) is read.

Since the minimum unit is 0.01%,
 $0x1388 \text{ (Hex.)} = 5000 \text{ (Dec.)} * 0.01 = 50 \text{ (%)}$

Also about the following parameters, these are the same as this.

- FD05 (Output voltage(real time)) Unit: 0.01% (V)
- FD04 (Voltage at DC bus (real time)) Unit: 0.01%(V)
- FD18 (Torque Unit: 0.01% (Nm)*

* When the motor information connected to the inverter set to the parameter (*F 4 0 5 - F 4 1 5*), torque monitor value "100%" is same as the rated torque of a motor in general.

3.4.6.11. FE36 (Analog input value VI/II)

The value inputted into the VI/II terminal is read.
The value range is 0x0 to 0x2710 (0 to 100.00 %).

- Also about FE35 (RR Input), it is the same as this parameter.

3.4.6.12. FE37 (RX Input)

The value inputted into the RX terminal is read.
The value range is 0xD8F0 to 0x2710 (-100.00 to +100.00 %).

3.4.6.13. FE60 - FE63 (My Monitor)

Refer to the function Manual (E6581335).

3.4.6.14. FE14 (Cumulative run time)

The operated cumulative time is read by the hexadecimal number.
For example, when cumulative operation time is 18 hours, 0x12 (16 hours) is read.
0x12 (Hex.) = 18 (Dec., hour)

3.4.6.15. FE40 (Analog output (FM))

The output value of FM terminal is read.
The value range is set to 0 to 65535 (0xFFFF).

- Also about FE41 (AM terminal output monitor), it is the same as this parameter.

3.4.6.16. FC91 (Alarm code)

bit	Function	0	1	Note
0	Over current alarm	Normal	Under alarm	" \underline{L} " blinking
1	Inverter over load alarm	Normal	Under alarm	" \underline{L} " blinking
2	Motor over load alarm	Normal	Under alarm	" \underline{L} " blinking
3	Over heat alarm	Normal	Under alarm	" H " blinking
4	Over voltage alarm	Normal	Under alarm	" \overline{P} " blinking
5	Under voltage of main power	Normal	Under alarm	-
6	(Reserved)	-	-	-
7	Under current alarm	Normal	Under alarm	-
8	Over torque alarm	Normal	Under alarm	-
9	OLr alarm	Normal	Under alarm	-
10	Cumulative run-time alarm	Normal	Under alarm	-
11	(Reserved)	-	-	-
12	(Reserved)	-	-	-
13	(Reserved)	-	-	-
14	Stop after instantaneous power off	-	Dec., Under stop	Refer to $F256$ value
15	Stop after LL continuance time	-	Dec., Under stop	Refer to UuL value

3.4.6.17. FD06 (Input TB Status)

bit	TB Name	Function (Parameter)	0	1
0	F	Input TB Function select 1 ($F111$)	OFF	ON
1	R	Input TB Function select 2 ($F112$)		
2*	ST	Input TB Function select 3 ($F113$)		
3	RES	Input TB Function select 4 ($F114$)		
4	S1	Input TB Function select 5 ($F115$)		
5	S2	Input TB Function select 6 ($F116$)		
6	S3	Input TB Function select 7 ($F117$)		
7	S4	Input TB Function select 8 ($F118$)		
8	L1	Input TB Function select 9 ($F119$)		
9	L2	Input TB Function select 10 ($F120$)		
10	L3	Input TB Function select 11 ($F121$)		
11	L4	Input TB Function select 12 ($F122$)		
12	L5	Input TB Function select 13 ($F123$)		
13	L6	Input TB Function select 14 ($F124$)		
14	L7	Input TB Function select 15 ($F125$)		
15	L8	Input TB Function select 16 ($F126$)		

* This function is reserved in VF-PS1.

3.4.6.18. FD07 (Output TB Status)

bit	TB Name	Function (Parameter)	0	1
0	OUT1	Output TB Function select 1 ($F130$)	OFF	ON
1	OUT2	Output TB Function select 2 ($F131$)		
2	FL	Output TB Function select 3 ($F132$)		
3	OUT3	Output TB Function select 4 ($F133$)		
4	OUT4	Output TB Function select 5 ($F134$)		
5	R1	Output TB Function select 6 ($F135$)		
6	OUT5	Output TB Function select 7 ($F136$)		
7	OUT6	Output TB Function select 8 ($F137$)		
8	R2	Output TB Function select 9 ($F138$)		
9	R3	Output TB Function select 10 ($F168$)		
10	R4	Output TB Function select 11 ($F169$)		
11 - 15	-	-	-	-

3.5. Connection Object

Class code 0x05. The Connection Class allocates and manages the internal resources associated with both I/O and Explicit Messaging Connections.

3.5.1. Connection Object Attributes

Attribute ID	Name	Data Type	Access Rules	Description	Default Value
1	Revision	UINT	Get	Revision of this object.	2
2	Max instance	UINT	Get	Maximum instance number of an object currently created in this class level of the device	2

3.5.2. Connection Object Instance Attributes

Connection Instance ID #	Description
1	References the Explicit Messaging Connection (refer to 3.5.2.1).
2	Reference the Polled I/O Connection(refer to3.5.3.1).

3.5.2.1. Explicit Messaging Connection Object Instance Attributes (Instance 1)

Attribute ID	Name	Data Type	Access Rules	Description	Default Value
1	state	USINT	Get	State of the object 00 = Non-existent 01 = Configuring 02 = Waiting for connection ID 03 = Established 04 = Timed Out 05 = Deferred Delete	-
2	instance_type	USINT	Get	Indicates connection type	0 (Explicit Message)
3	transportClass_trigger	USINT	Get	Connection behavior	0x83 (Server Transport Class 3)
4	produced_connection_id	UINT	Get	Placed in CAN ID field when transmitting	0x700*
5	consumed_connection_id	UINT	Get	CAN ID field value denoting received messages	0x602*
6	initial_comm_characteristics	USINT	Get	Defines producing / consuming message groups	0x21 (Send: Gr. 3) (Resp: Gr. 3)
7	produced_connection_size	UINT	Get	Max number of bytes transmitted across this connection	55
8	consumed_connection_size	UINT	Get	Max number of bytes received across this connection	55
9	expected_packet_rate	UINT	Get/Set	Defines timing associated with this connection	2500 (ms)
12	watchdog_timeout_action	USINT	Get/Set	Inactivity/watchdog timeout action	1 (Auto Delete)
13	produced_connection_path_length	UINT	Get	Number of bytes in produced_connection_path attribute	0
14	produced_connection_path	USINT (ARRAY)	Get	Specifies Application Object(s) whose data is to be produced by this connection	Empty
15	consumed_connection_path_length	UINT	Get	Number of bytes in consumed_connection_path attribute	0
16	consumed_connection_path	USINT (ARRAY)	Get	Specifies Application Object(s) whose data is to be consumed by this connection	Empty

* connection id dependant on device Mac ID

3.5.3. Connection Class Common Services

Service Code	Service Name	Supported		Description of Service
		Class	Instance	
0x05	Reset	N/A	Yes	Used to reset all resetable connection objects.
0x0E	Get_Attribute_Single	Yes	Yes	Returns the contents of the specified attribute.
0x10	Set_Attribute_Single	N/A	Yes	Modifies the value of the specified attribute.

3.5.3.1. Poll Connection Object Instance Attributes (Instance 2)

Attribute ID	Name	Data Type	Access Rules	Description	Default Value
1	state	USINT	Get	State of the object 00 = Non-existent 01 = Configuring 02 = Waiting for connection ID 03 = Established 04 = Timed Out 05 = Deferred Delete	-
2	instance_type	USINT	Get	Indicates connection type	1 (I/O)
3	transportClass_trigger	USINT	Get	Connection behavior	0x83 Server (Transport Class 3)
4	produced_connection_id	UINT	Get	Placed in CAN ID field when transmitting	0x3C0*
5	consumed_connection_id	UINT	Get	CAN ID field value denoting received messages	0x405*
6	initial_comm_characteristics	USINT	Get	Defines producing / consuming message groups	0x1 (Send: Gr. 1) (Resp: Gr. 2)
7	produced_connection_size	UINT	Get	Max number of bytes transmitted across this connection	4
8	consumed_connection_size	UINT	Get	Max number of bytes received across this connection	4
9	expected_packet_rate	UINT	Get/Set	Defines timing associated with this connection	250
12	watchdog_timeout_action	USINT	Get	Inactivity/watchdog timeout action	0 (Timed Out)
13	produced_connection_path_length	UINT	Get	Number of bytes in produced_connection_path attribute	6
14	produced_connection_path	USINT (ARRAY)	Get	Specifies Application Object(s) whose data is to be produced by this connection	0x20 0x04 0x24 0x46 0x30 0x03 (Instance 70)
15	consumed_connection_path_length	UINT	Get	Number of bytes in consumed_connection_path attribute	6
16	consumed_connection_path	USINT (ARRAY)	Get	Specifies Application Object(s) whose data is to be consumed by this connection	0x20 0x04 0x24 0x14 0x30 0x03 (Instance 20)
17	production_inhibit_time	UINT	Get	Defines minimum time between new data production	0

* connection id dependant on device Mac ID

3.5.4. Connection Class Common Services

Service Code	Service Name	Supported		Description of Service
		Class	Instance	
0x05	Reset	Yes	Yes	Used to reset all resettable connection objects.
0x0E	Get_Attribute_Single	Yes	Yes	Returns the contents of the specified attribute.
0x10	Set_Attribute_Single	N/A	Yes	Modifies the value of the specified attribute.

3.5.5. Connection Class Specific Services

The Connection Class provides no object specific services.

3.6. Motor Data Object

Class code 0x28. This object serves as a database for motor parameters.

3.6.1. Motor Data Object Class Attributes

Attribute ID	Name	Data Type	Access Rules	Description	Default Value
1	Revision	UINT	Get	Revision of this object	1
2	Max instance	UINT	Get	Maximum instance number of an object currently created in this class level of the device	1
6	Max ID of class attributes	UNIT	Get	The attribute ID number of the last class attribute of the class definition implemented in the device.	7
7	Max ID of instance attributes	UNIT	Get	The attribute ID number of the last instance attribute of the class definition implemented in the device.	15

3.6.2. Motor Data Object Instance Attributes

Attribute ID	Name	Data Type	Access Rules	Description	Default Value
1	Number of Attributes	USINT	Get	Number of Attributes supported	7
2	Attributes List	USINT (ARRAY)	Get	List of attributes supported	-
3	Motor Type	USINT	Get	0 - Non-standard motor 1 - PM DC Motor 2 - FC DC Motor 3 - PM Synchronous Motor 4 - FC Synchronous Motor 5 - Switched Reluctance Motor 6 - Wound Rotor Induction Motor 7 - Squirrel Cage Induction Motor 8 - Stepper Motor 9 - Sinusoidal PM BL Motor 10 - Trapezoidal PM BL Motor	7
6	Rated Current	UINT	Get/Set	Rated Current [100mA]	-
7	Rated Voltage	UINT	Get/Set	Rated Voltage [V]	-
8	Rated Power	UDINT	Get/Set	Power at rated frequency [W]	-
9	Rated Frequency	UINT	Get/Set	Rated Electrical Frequency [Hz]	-
12	Pole Count	UINT	Get	Number of poles in the motor	-
15	Base Speed	UINT	Get/Set	Nominal speed at rated frequency from nameplate [min^{-1}]	-

3.6.3. Motor Data Object Common Services

Service Code	Service Name	Supported		Description of Service
		Class	Instance	
0x0E	Get_Attribute_Single	N/A	Yes	Returns the contents of the specified attribute.
0x10	Set_Attribute_Single	N/A	Yes	Modifies the value of the specified attribute.

3.6.4. Motor Data Object Specific Services

The Motor Data Object provides no object specific services.

3.7. Control Supervisor Object

Class code 0x29. This object models all the management functions for devices within the DeviceNet “Hierarchy of Motor Control Devices”. The behavior of motor control devices is described by the State Transition Diagram.

3.7.1. Control Supervisor Object Class Attributes

Attribute ID	Name	Data Type	Access Rules	Description	Default Value
1	Revision	UINT	Get	Revision of this object	1
2	Max instance	UINT	Get	Maximum instance number of an object currently created in this class level of the device	1
6	Max ID of class attributes	UNIT	Get	The attribute ID number of the last class attribute of the class definition implemented in the device.	7
7	Max ID of instance attributes	UNIT	Get	The attribute ID number of the last instance attribute of the class definition implemented in the device.	15

3.7.2. Control Supervisor Object Instance Attributes

Attribute ID	Name	Data Type	Access Rules	Description	Default Value
1	Number of Attributes	USINT	Get	Number of Attributes supported	11
2	Attribute List	USINT (ARRAY)	Get	List of attributes supported	-
3	Run 1	BOOL	Get/Set	See Run/Stop Event Matrix 00 = Stop 01 = Run	-
4	Run 2	BOOL	Get/Set	See Run/Stop Event Matrix 00 = Stop 01 = Run	-
5	Net Control	BOOL	Get/Set	Requests Run/Stop control to be local or from network. 0 = Local Control 1 = Network Control Note that the actual status of Run/Stop control is reflected in attribute 15, CtrlFromNet.	-
6	State	USINT	Get	0 = Vendor Specific 1 = Startup 2 = Not_Ready 3 = Ready 4 = Enabled 5 = Stopping 6 = Fault_Stop 7 = Faulted	-
7	Running 1	BOOL	Get	1 = (Enabled and Run1) or (Stopping and Running1) or (Fault_Stop and Running1) 0 = Other state	-
8	Running 2	BOOL	Get	1 = (Enabled and Run2) or (Stopping and Running2) or (Fault_Stop and Running2) 0 = Other state	-
9	Ready	BOOL	Get	1 = Ready or Enabled or Stopping 0 = Other state	-
10	Faulted	BOOL	Get	1 = Fault Occurred (latched) 0 = No Faults present	-
11	Warning	BOOL	Get	1 = Warning (not latched) 0 = No Warnings present	-
12	Fault Reset	BOOL	Get/Set	0->1 = Fault Reset 0 = No action	-
15	Control From Net	USINT	Get	Status of Run/Stop control source. 0 = Control is local 1 = Control is from network	-

3.7.3. Control Supervisor Object Common Services

Service Code	Service Name	Supported		Description of Service
		Class	Instance	
0x05	Reset	N/A	Yes	Used to reset all resettable connection objects.
0x0E	Get_Attribute_Single	N/A	Yes	Returns the contents of the specified attribute.
0x10	Set_Attribute_Single	N/A	Yes	Modifies the value of the specified attribute.

3.7.4. Control Supervisor Object Specific Services

The Control Supervisor Object provides no object specific services.

3.7.5. Run/Stop Event Matrix

Run1	Run2	Trigger Event	Run Type
0	0	Stop	No Action
0 -> 1	0	Run	Run1
0	0 -> 1	Run	Run2
0 -> 1	0 -> 1	No Action	No Action
1	1	No Action	No Action
1 -> 0	1	Run	Run2
1	1 -> 0	Run	Run1

3.7.6. Control Supervisor State Transition Diagram

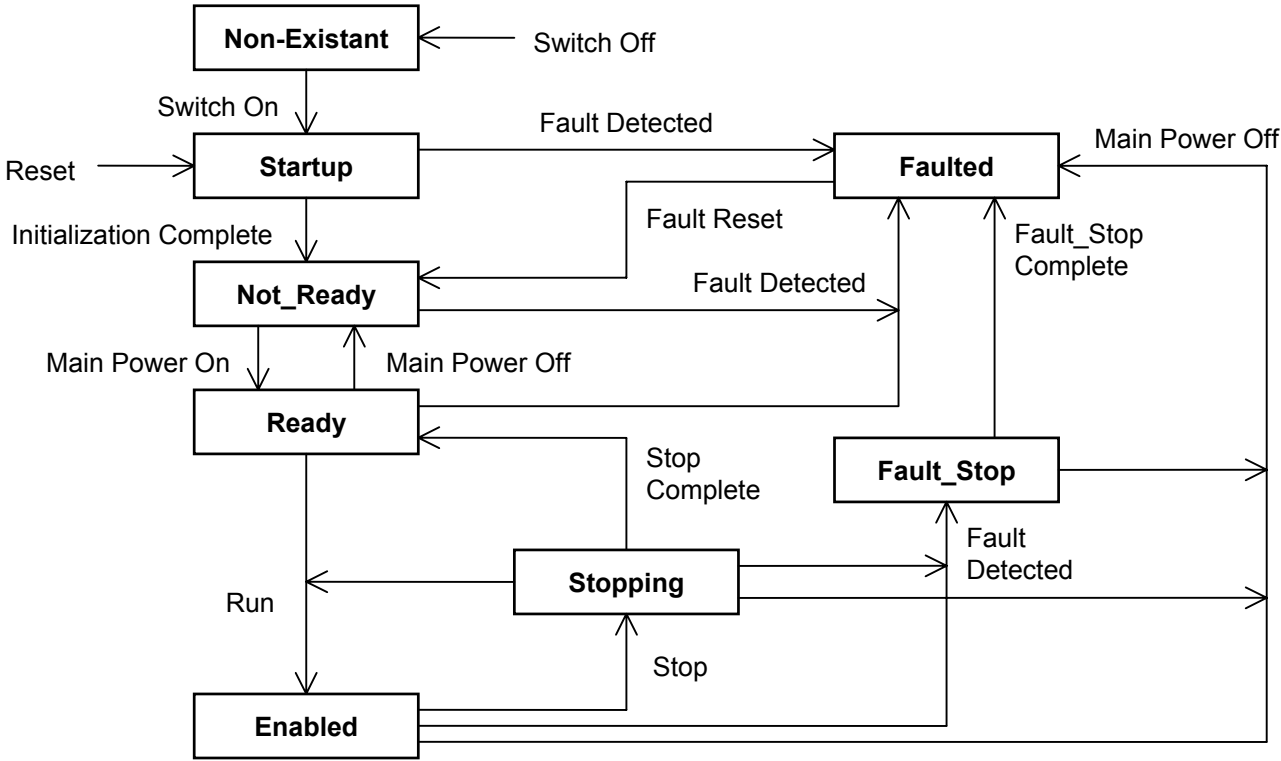

3.8. AC/DC Drive Object

Class code 0x2A. This object models the functions specific to an AC or DC Drive. e.g. speed ramp, torque control etc.

3.8.1. AC/DC Drive Object Class Attributes

Attribute ID	Name	Data Type	Access Rules	Description	Default Value
1	Revision	UINT	Get	Revision of this object	1
2	Max instance	UINT	Get	Maximum instance number of an object currently created in this class level of the device	1
6	Max ID of class attributes	UNIT	Get	The attribute ID number of the last class attribute of the class definition implemented in the device.	7
7	Max ID of instance attributes	UNIT	Get	The attribute ID number of the last instance attribute of the class definition implemented in the device.	46

3.8.2. AC/DC Drive Object Instance Attributes

Attribute ID	Name	Data Type	Access Rules	Description	Default Value
1	Number of Attributes	USINT	Get	Number of Attributes supported	16
2	Attribute List	USINT (ARRAY)	Get	List of Attributes supported	-
3	At Reference	BOOL	Get	1 = Drive actual at reference (speed or torque reference) based on mode	-
4	Net Reference	BOOL	Get/Set	Requests torque or speed reference to be local or from network. 0 = Set Reference not DN Control 1 = Set Reference at DN Control Note that the actual status of torque or speed reference is reflected in attribute 29, RefFromNet.	-
6	Drive Mode	USINT	Get	0 = Vendor specific mode 1 = Open loop speed (Frequency) 2 = Closed loop speed control 3 = Torque control 4 = Process control (e.g. PI) 5 = Position control	-
7	Speed Actual	INT	Get	Actual drive speed (best approximation) Units: min^{-1}	-
8	Speed Reference	INT	Get/Set	Speed reference Units: min^{-1}	-
9	Current Actual	INT	Get	Actual motor phase current Units: 100mA	-
10	Current Limit	INT	Get/Set	Motor phase current limit Units: 100mA	-
11	Torque Actual	INT	Get	Actual torque Units: Nm	-
15	Power Actual	INT	Get	Torque reference Units: Nm	-
18	Accel Time	UINT	Get/Set	Acceleration time Time from 0 to High Speed Limit Units: ms	-
19	Decel Time	UINT	Get/Set	Acceleration time Time from 0 to High Speed Limit Units: ms	-
20	Low Speed Limit	UINT	Get/Set	Minimum speed limit Units: min^{-1}	-
21	High Speed Limit	UINT	Get/Set	Maximum speed limit Units: min^{-1}	-
26	Power Scale	SINT	Get	Power scaling factor.	-
29	Ref From Net	BOOL	Get	Status of torque/speed reference 0 = Local torque/speed reference 1 = DeviceNet torque/speed reference	-
46	Drive on Hours	DINT	Get	Number of hours Units: h	-

3.8.3. AC/DC Drive Object Common Services

Service Code	Service Name	Supported		Description of Service
		Class	Instance	
0x0E	Get_Attribute_Single	Yes	Yes	Returns the contents of the specified attribute.
0x10	Set_Attribute_Single	N/A	Yes	Modifies the value of the specified attribute.

3.8.4. AC/DC Drive Object Specific Services

The AC/DC Drive Object provides no object specific services.

3.9. Vender Specific Device Profiles

Class code 0x64. This object provides VF-AS1/PS1's Parameter access.

All parameter's Attribute ID is 3.

Refer to the following about each parameter's Instance ID.

Attribute ID of all parameters are 3. Moreover, about the instance ID of each parameter, it becomes "parameter communication number + 0x4000".

In the case of the parameter from which a communication number begins in "F", it becomes "parameter communication number - 0x8000 (same as bit15 set to 0)".

About the details of the contents of a parameter, please refer to a VF-AS1/PS1 instructions manual.

Example 1.

In case of Basic parameter "CM0d - Command mode selection",
Communication No: **0003** -> Instance ID: **4003**

Example 2.

In case of Extended parameter "F268 - Updown frequency default value",
Communication No: **0268** -> Instance ID: **4268**

Example 3.

In case of Monitor parameter "FE03 - Output current",
Communication No: **FE03** -> Instance ID: **7E03**

* Monitor parameter can access "Get" only.

For example, when "Acc. time" is set to 5 sec., since the minimum unit is 0.1s,

$$5 / 0.1 = 50 = 0x0032 \text{ (Hex.)}$$

Since the communication number of " Acc. time" is "0009", it writes "0x0032" in instance ID "4009."

Moreover, when the "highest frequency" is read, "0x1F40" is read.

$$0x1F40 = 8000 \text{ (Dec.)}$$

Since the minimum unit is 0.01Hz,

$$8000 * 0.01 = 80\text{Hz}$$

3.10. About EDS-file

Even if access to each parameter of VF-AS1/PS1 uses a configuration tool and an EDS file, it is possible. As for acquisition of an EDS file, it is possible to download from homepage of our company.

Please use what was in agreement with the software version of usage's VF-AS1/PS1.