

Infrared Sensors recognise the natural radiation of warm objects over a great distance. They are applied when other proximity switches cannot operate properly because of high radiation or ambient temperatures.

A special feature of OKA/OKB 20TA is a learning behaviour (teach-in) witch reaches max. accuracy and reproducibility of the switching point. The changes of temperature of object and background radiation occurring during operation are added electronically in such a way that safe signals are reached also in case of different operation conditions.

autom.
Teach - In
Function

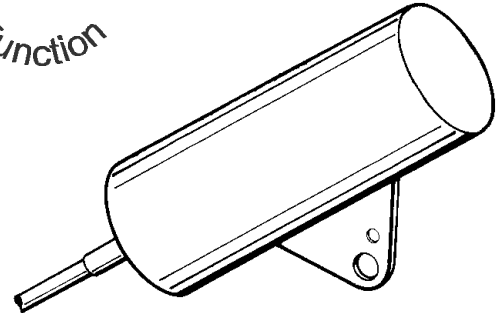

Technical Data

Type	OKA 20TA.38 G
Art.-Nr.	6140(A-Z)
Response temperature adjustable	350 - 800 °C
View angle	2 °
Distance ratio	29:1
Detected surface at 2m	Ø 70 mm
Output	PNP n. o. PNP n. c.
Supply voltage	10 - 55 V DC
Ripple voltage	< 15 %
Load current max.	0 - 400 mA
Short-time load current	0,8 A / 100 ms 2 A / 10 ms
Short circuit protection	yes, pulsing
Current absorbed	13 mA
Voltage drop	2 V
Operating frequency	2000 Hz
Switching hysteresis	3 - 10 %
Ambient temperature	-20 to +75 °C
Protection class	IP 67
Connection	2 m POKT-Therm cable
Service plug (factory settings)	S4 (M12x1) 5 pol.
Function display	Duo LED
Housing material	stainless steel
Accessories	Art.-Nr.
(not included in the scope of supply)	
Swivel Stand HM 2	9816B
Tube OL 19	9828A

Diagram of Connections

