



CAUTIONS TO BE TAKEN TO ENSURE SAFETY

- For those persons involved with the operation / service of your system, including Kawasaki Robot, they must strictly observe all safety regulations at all times. They should carefully read the Manuals and other related safety documents.
- Products described in this catalogue are general industrial robots. Therefore, if a customer wishes to use the Robot for special purposes, which might endanger operators or if the Robot has any problems, please contact us. We will be pleased to help you.
- Be careful as Photographs illustrated in this catalogue are frequently taken after removing safety fences and other safety devices stipulated in the safety regulations from the Robot operation system.



ISO certified in Akashi Works.

INQUIRIES

KAWASAKI HEAVY INDUSTRIES, LTD.

www.khi.co.jp/robot/

Tokyo Head Office/Robot Division
World Trade Center Bldg., 4-1, Hamamatsu-cho 2-chome, Minato-ku, Tokyo 105-6116, Japan
Phone: +81-3-3435-6908
Fax: +81-3-3437-9880

Akashi Works/Robot Division
1-1, Kawasaki-cho, Akashi, Hyogo 673-8666, Japan
Phone: +81-78-921-2946
Fax: +81-78-923-6548

KAWASAKI ROBOTICS (U.S.A.), INC.

28140 Lakeview Drive, Wixom, MI 48393, U.S.A.
www.kawasakirobot.com
Phone: +1-248-446-4100
Fax: +1-248-446-4200

KAWASAKI ROBOTICS (UK) LTD.

Units 6 & 7, Easter Court, Europa Boulevard, Westbrook Warrington WA5 7ZB, United Kingdom
www.kawasakirobot.uk.com
Phone: +44-1925-71-3000
Fax: +44-1925-71-3001

KAWASAKI ROBOTICS GmbH

29 Sperberweg, 41468 Neuss, Germany
www.kawasakirobot.de
Phone: +49-2131-34260
Fax: +49-2131-3426-22

KAWASAKI MACHINE SYSTEMS KOREA, LTD.

69BL-1LT, 638, Gojan-Dong, Namdong-Gu, Incheon, 405-817, Korea
www.kawasakirobot.co.kr
Phone: +82-32-821-6941
Fax: +82-32-821-6947

KAWASAKI ROBOTICS (TIANJIN) CO., LTD.

C-1-9, No.41, 5th avenue, TEDA, Tianjin 300457 China
www.kawasakirobot.cn
Phone: +86-22-5983-1888
Fax: +86-22-5983-1889

KAWASAKI MOTORS ENTERPRISE (THAILAND) CO., LTD.

(ROBOT DIVISION)
129 Rama 9 Road, Kwaeng Huay-Kwang, Khet Huay-Kwang, Bangkok 10310, Thailand
<http://www.khi.co.jp/robot/th/>
Phone: +66-2-247-7935-8
Fax: +66-2-247-7934

Agent

* Materials and specifications are subject to change without notice.

This catalog is printed on recycled paper.

Kawasaki Robot

Simple and friendly



Kseries
Explosion-proof Painting Robots
and Painting Package Cells
Japan & Asia

A selection of robots is available to match your painting application.

Simple and friendly

Kawasaki Robot

K
series

Manipulators

Kawasaki K-series robots are explosion-proof painting robots developed on Kawasaki's concept of "Simple and Friendly." This range of robots covers all painting applications from small to large, and the fully integrated hose system provides maximum protection against external dust and dirt.



Painting Line for Car Bumpers



Automobile body coating line

Photo : Mazda's 3 wet-on coating system clear coating process

Our robot is available in a "package cell" allowing production to commence almost instantly.

Package Cell

If you need to get your painting system operational quickly, Kawasaki painting package cells are available. These package cells arrive as a compact, ready-to-use units that can be easily installed in a limited space, allowing you to begin the painting process immediately.

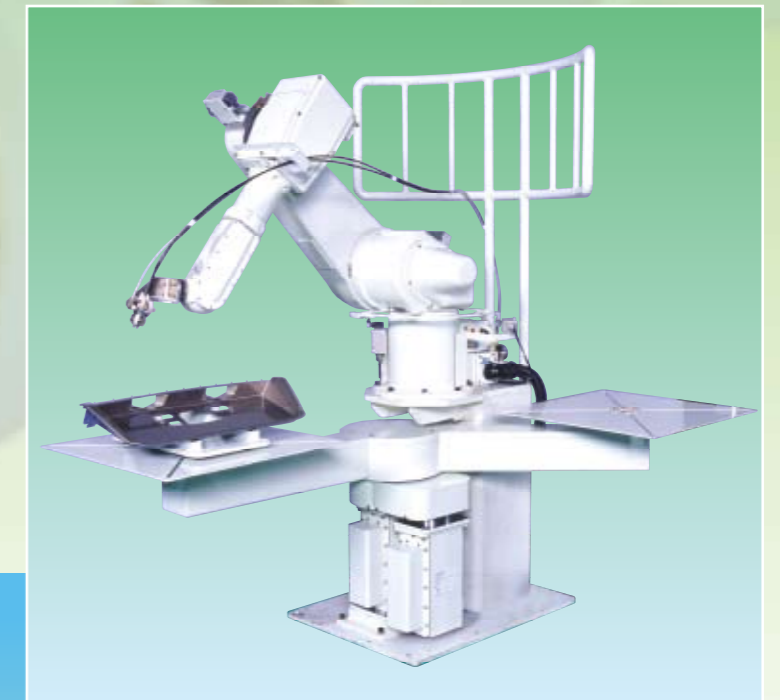

Servo twister + KF121



Servo shuttle + KF193

Manipulators



1

A broad range of robots

Kawasaki offers four basic types of painting robot from the KF121 for small workpieces to the KG264 for inner and outer bodies of automobiles. We provide a range of robots that covers the requirements of all applications and installations.

2

Built-in hoses

Each type of robot is fitted with built-in hoses as standard. The hollow wrist with fully integrated hoses minimizes the likelihood of mist and spray sticking to the tubing and reduces the chance of dust adhering to the workpiece. The inner diameter of the hollow wrist is either 40 or 70 mm.



Arm with internal hose

3

Enhanced peripheral units

A control panel is provided to enhance the ease of system development and to interface with the robot traveling unit, workpiece transfer unit, rotation unit, and other devices.

4

Significant painting experience

Gathering 30 years of painting robot experience has enabled Kawasaki to put together a robot that will match your every need. The K series has used this information and is now equipped with more advanced functions than ever, resulting in a robot of great capability.

5

Customer support

Our professional staff will be available for support from the initial planning stage right up to system start up. This service will be of great benefit to those new to painting applications.

Variation of Wrists

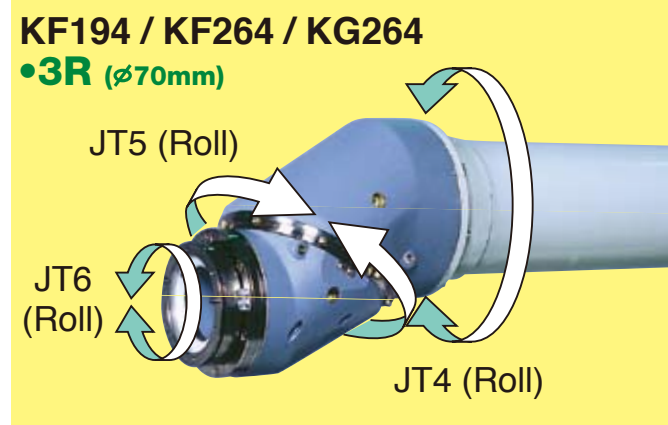
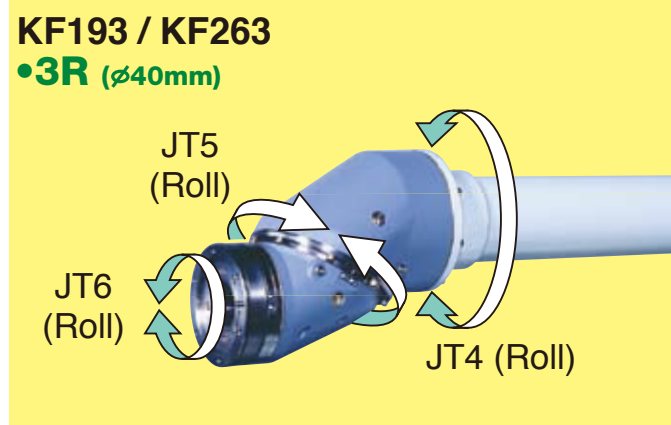
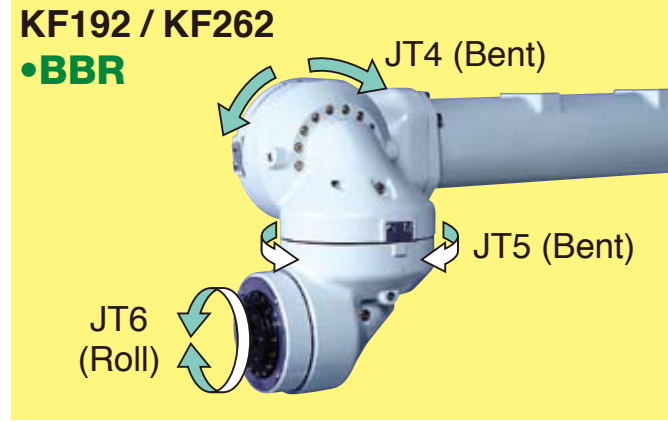
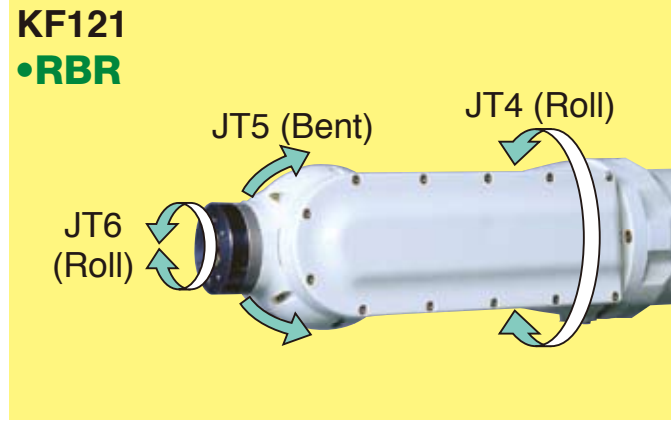

Specifications

| Model | KF121 | KF192 | KF193 | KF194 | KF262 | KF263 | KF264 | KG264 | |
|---------------------------|--|-------------------------|--------------------------|--------------------------|------------------------|--------------------------|--------------------------|----------------------------|------------------------|
| Degrees of Freedom | 6 axes | | | | | | | | |
| Wrist Type | RBR | BBR | 3Rø40 (Hose Built-in) | 3Rø70 (Hose Built-in) | BBR | 3Rø40 (Hose Built-in) | 3Rø70 (Hose Built-in) | | |
| Axis Work Envelope | Max. Stroke | JT1 (Turning) | ±150° | | | | | ±120° | |
| | | JT2 (lower arm) | +110° ~ -60° | | | | | +120° ~ -60° | |
| | | JT3 (Upper arm) | +90° ~ -80° | | | | | +90° ~ -65° | |
| | Max. Speed | JT4 | ±270° | ±360° | ±720° | ±720° | ±360° | ±720° | |
| | | JT5 | ±145° | ±360° | ±720° | ±720° | ±360° | ±720° | |
| | | JT6 | ±360° | ±360° | ±410° | ±410° | ±360° | ±410° | |
| Repeatability | ±0.2 mm | ±0.5 mm | | | | | | | |
| Max. Reach | 1,240 mm | 1,973 mm | 1,973 mm | 1,978 mm | 2,665 mm | 2,665mm | 2,668 mm | 2,665 mm | |
| Max. Payload | 5 kg | Wrist: 12 kg Arm: 20 kg | | | | | | Wrist: 20 kg Arm: 30 kg | |
| Moment | JT4 | 7.8 N·m | 33.3 N·m | 33.2 N·m | 35.3 N·m | 33.3 N·m | 33.2 N·m | 35.4 N·m | 79.9 N·m |
| | JT5 | 7.8 N·m | 28.8 N·m | 26.7 N·m | 27.7 N·m | 28.8 N·m | 26.7 N·m | 27.7 N·m | 61.3 N·m |
| | JT6 | 2.9 N·m | 7.9 N·m | 7.9 N·m | 7.9 N·m | 7.9 N·m | 7.9 N·m | 7.9 N·m | 15.6 N·m |
| Moment of Inertia | JT4 | 0.17 kg·m ² | 1.28 kg·m ² | 1.27 kg·m ² | 1.44 kg·m ² | 1.28 kg·m ² | 1.27 kg·m ² | 1.45 kg·m ² | 3.33 kg·m ² |
| | JT5 | 0.17 kg·m ² | 0.96 kg·m ² | 0.82 kg·m ² | 0.89 kg·m ² | 0.96 kg·m ² | 0.82 kg·m ² | 0.89 kg·m ² | 1.95 kg·m ² |
| | JT6 | 0.06 kg·m ² | 0.11 kg·m ² | 0.11 kg·m ² | 0.10 kg·m ² | 0.11 kg·m ² | 0.11 kg·m ² | 0.11 kg·m ² | 0.12 kg·m ² |
| Mass | 140 kg | 690 kg | 720 kg | 750 kg | 720 kg | 740 kg | 770 kg | 795 kg | |
| Explosion Protection | Combination of pressurized type and intrinsically safety type (Expib IIBT4 / Exib IIBT4) | | | | | | | | |
| Ambient Temperature Range | 0 ~ 40 °C | | | | | | | | |
| Body Color | Munsell 10GY9/1 equivalent | | | | | | | | |

Maximum reach : The RBR (Roll Bend Roll) wrist refers to the distance from the centre of JT1 to the centre of JT5. Other options or Software : Please contact us.
The BBR (Bend Bend Roll) wrist is the distance from the top arm centre line to the JT4 axis.
The 3R (Roll Roll Roll) wrist is the distance from JT1 to the axis cross-point between JT4 and JT5.

Motion Range & Dimensions

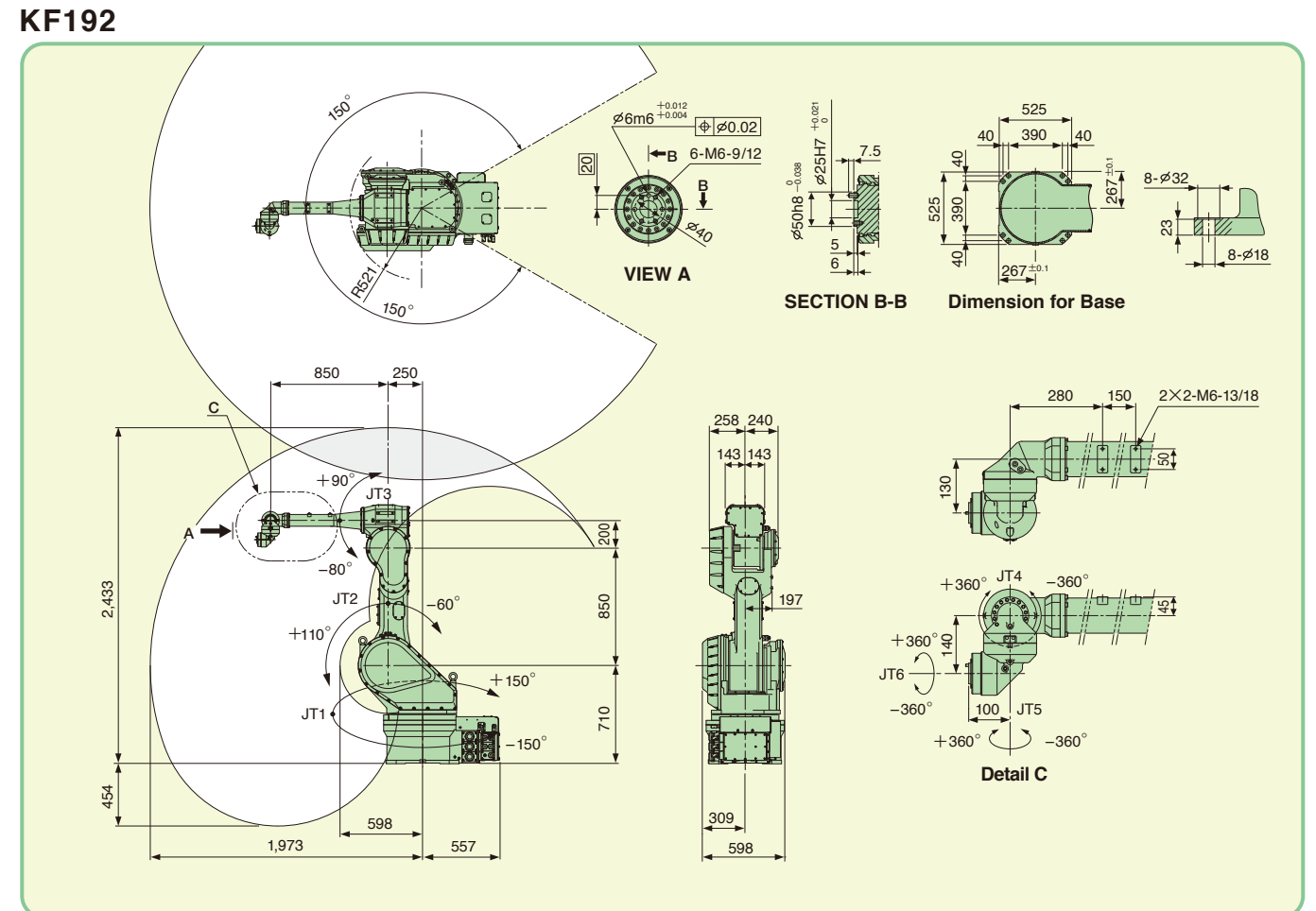
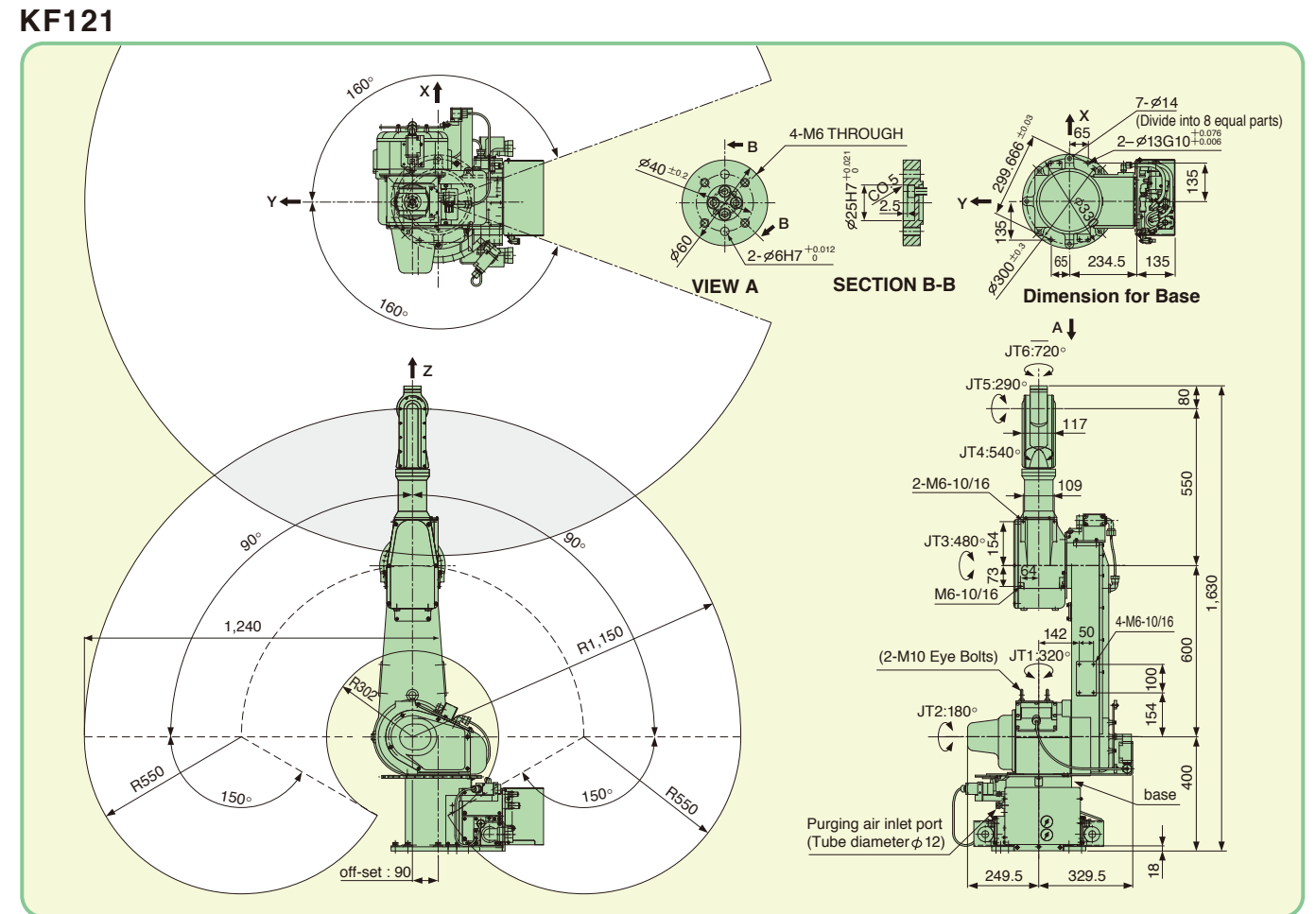

Motion Range & Dimensions

KF193

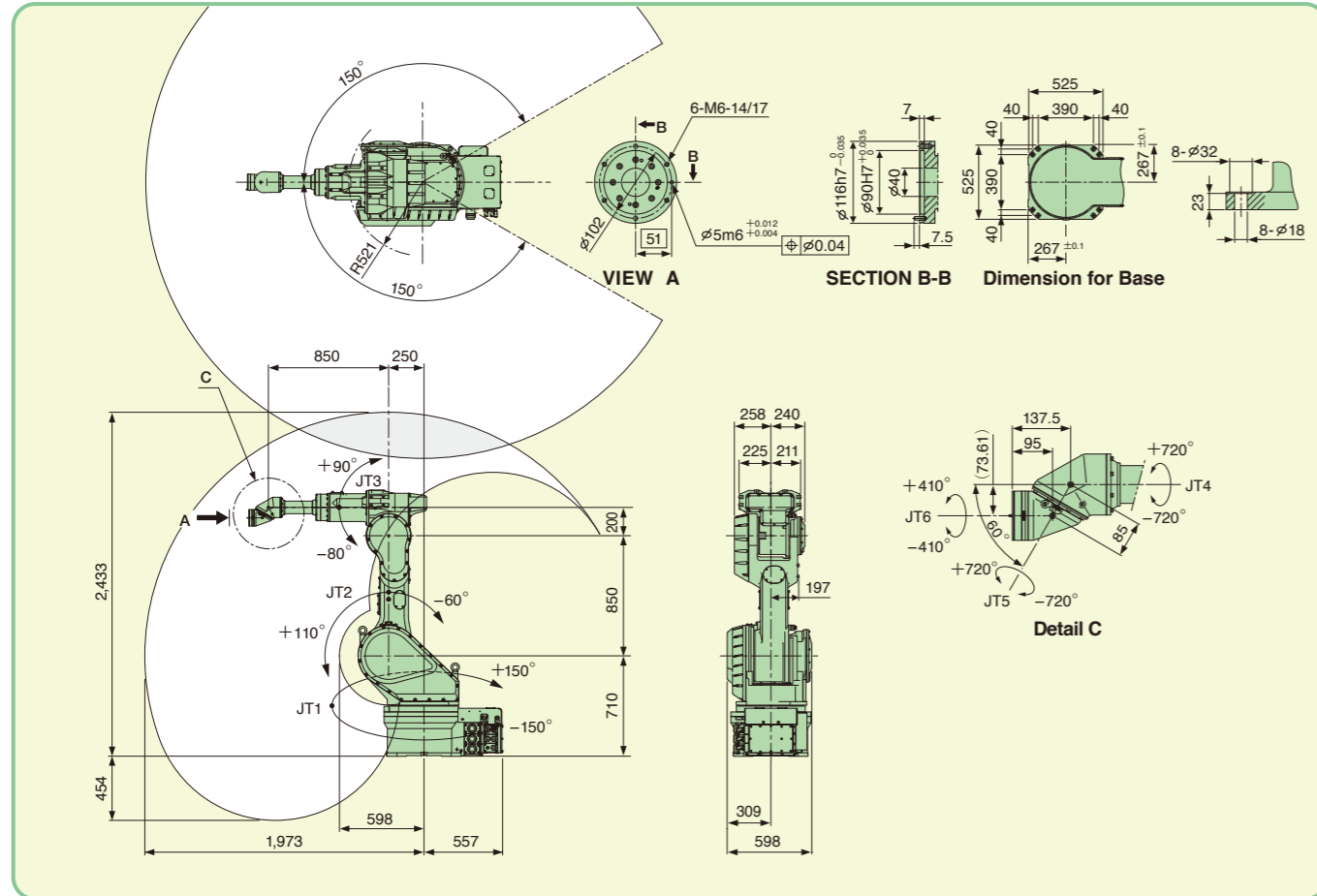

KF262

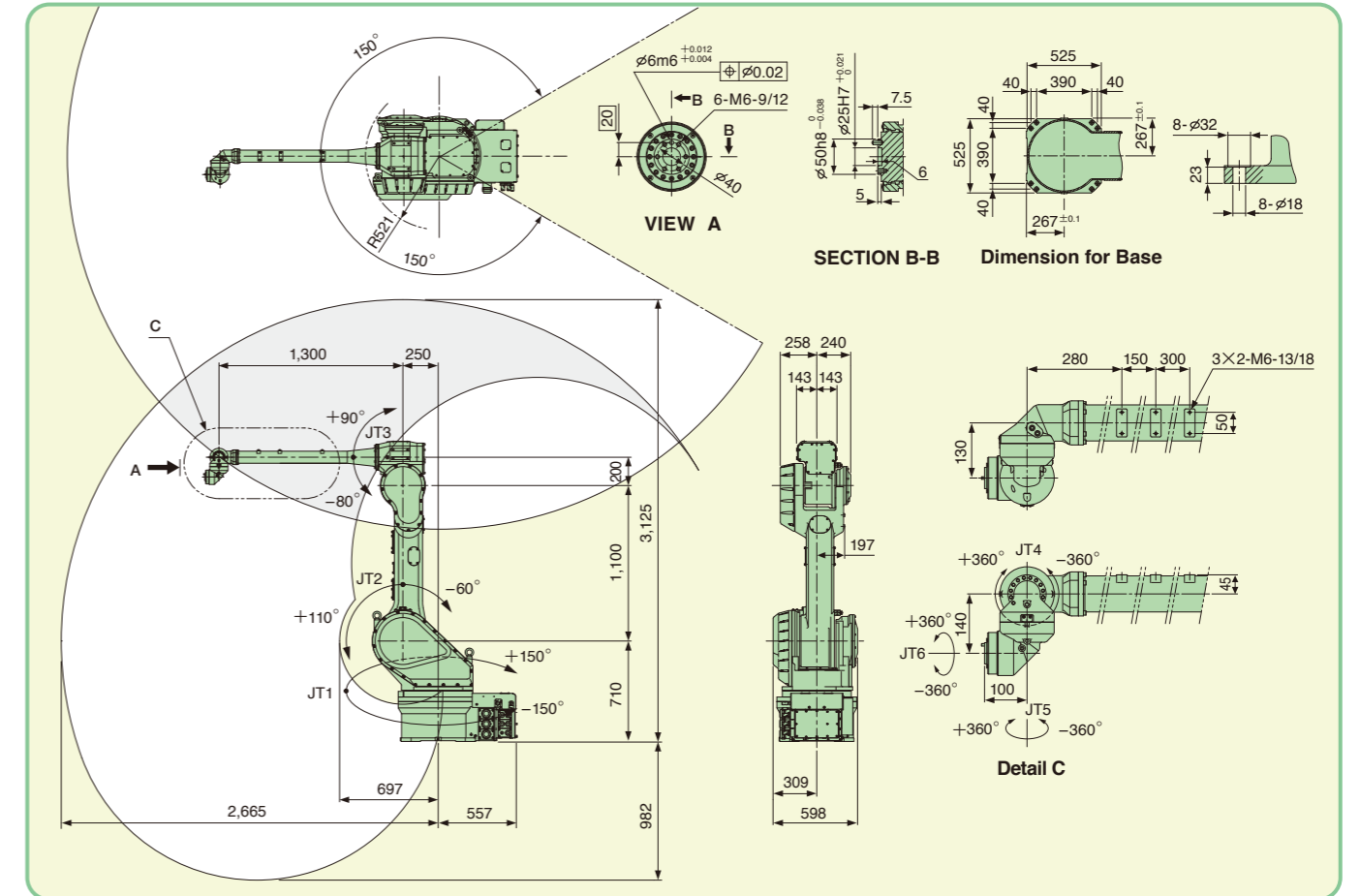

KF194

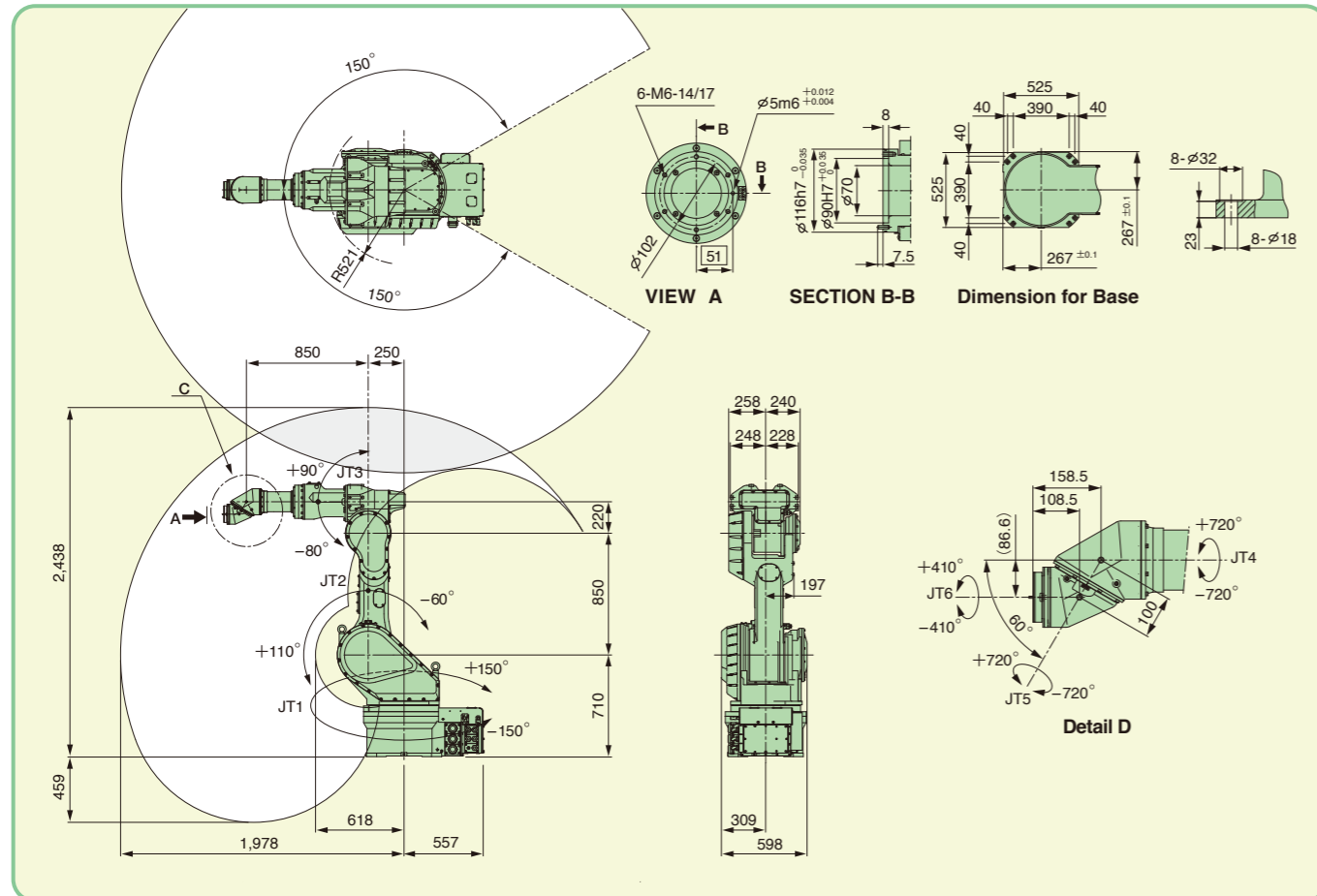

KF263

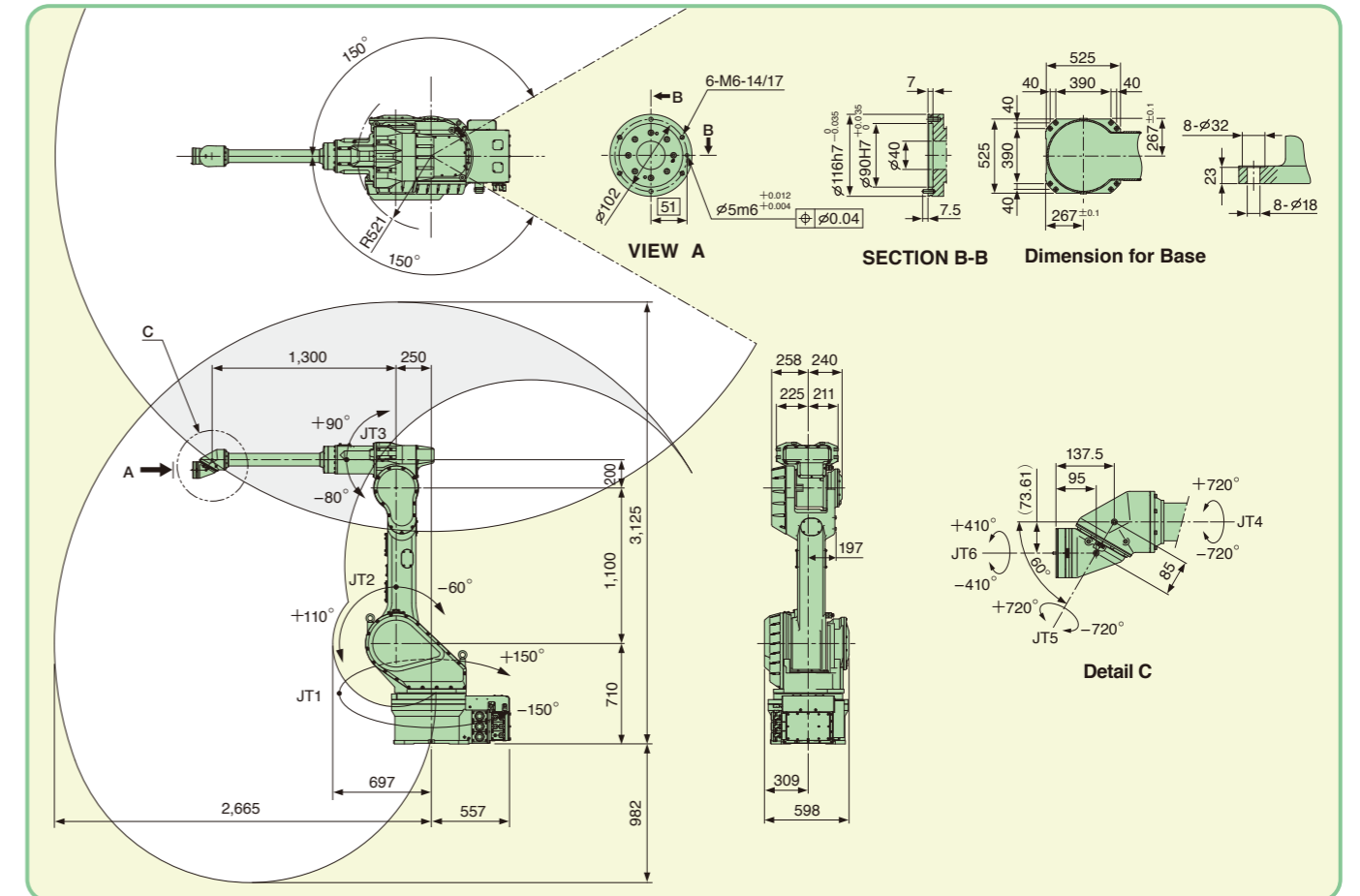

Motion Range & Dimensions

KF264

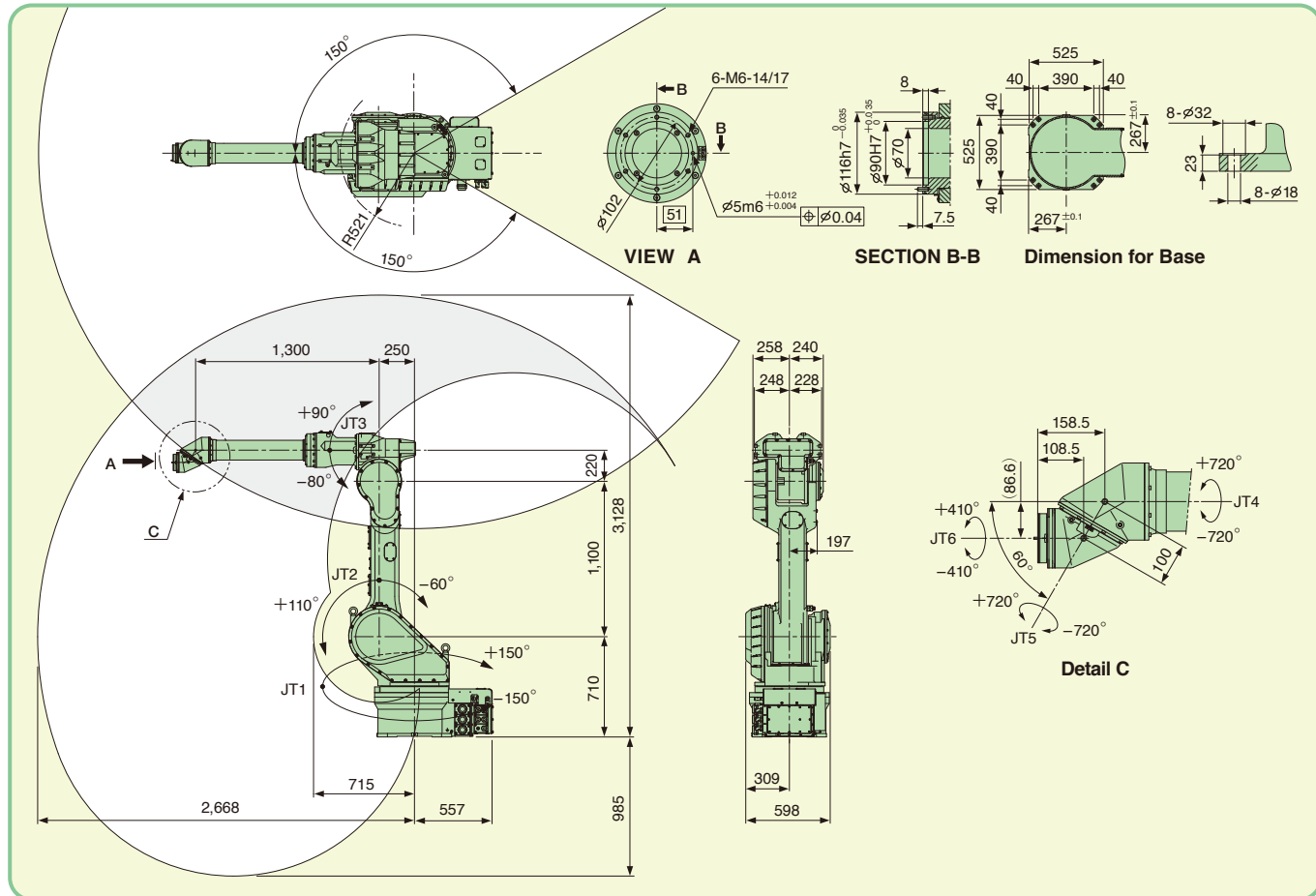

KG264

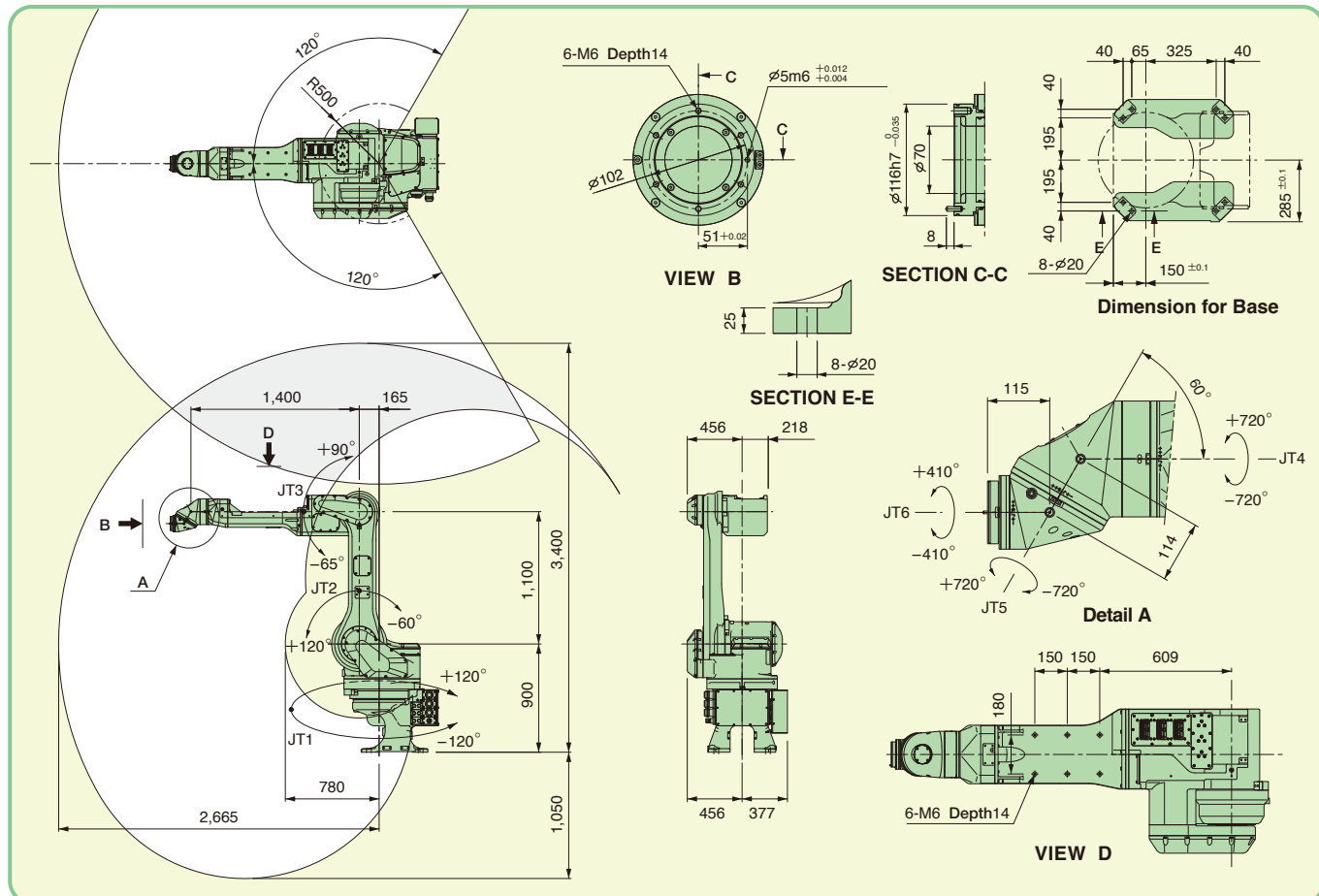

Controller (E25/E27)



The E-controller, delivering unprecedented quality with a compact size, was developed to respond to the requirements of our customers. Kawasaki's past achievements and experience have led to the development of the most technically advanced controller available. This industry-leading design provides improved performance and easy operation that surpasses all expectations.

•Features

1 Compact

We have reduced the controller's foot print and overall volume to make high-density layouts easy to achieve.

2 Explosion-proof teach pendant

The explosion-proof color LCD with its large touch panel allows users to teach, edit, and monitor information such as current position and I/O signals in the explosion-proof area. The interface panel can be customized to meet user preferences, while the backlit screen is easy to read in dark locations.

3 User-friendly operation system

The operating system has now fully matured into a more user-friendly design. The operator can switch on the motors and activate the cycle start all from the teach pendant, providing more convenient system control. Two information screens can be displayed simultaneously to provide access to different types of information (for example, positional and signal information).

4 Painting unit control functions (option)

By controlling the CCV, the electro-pneumatic regulator, and the rotation of the discharge control gear pump from the robot controller's CPU board, this low cost, flexible system is compatible with a range of painting devices. You can also set up painting conditions and conduct discharge rate calibration on the teach pendant screen.

5 Using the latest technologies

The enhanced CPU capacity has resulted in more accurate trajectory control, faster program execution, and quicker saving and loading of files, as well as other advantages. In addition the memory has been expanded to provide greater program storage capacity, while a USB port is also provided as standard for connecting external storage devices.

6 Easier maintenance

With modular components and fewer cables, Kawasaki has developed a controller that is compact, and easy to maintain. A host of maintenance functions are available, including the DIAG function for self-diagnostics, a maintenance support function that can handle not only hardware errors but also application errors, a Web server that allows remote diagnostics, and more.

7 Highly expandable

By installing an additional amplifier, and adding workpiece transfer devices (tombow, shuttle, turntable, etc.), travel unit and gear pump, etc., the system can accept up to three external axes. The system is compatible with a large number of field buses for controlling peripheral devices. Combination with software sequencer function (KLogic), which can be edited on the teach pendant, allows easy structuring of a highly sophisticated system.



● Specifications

| | | Standard | Option |
|---------------------------|--------------------|--|-------------------------------|
| Model | | E25/E27 | |
| Dimensions | | W500×D550×H1,400 mm | |
| Structure | | Self-standing main enclosure | |
| Number of Controlled Axes | | 6 axes | Max. 9 axes |
| Drive System | | Full digital servo system | |
| Coordinate Systems | | Joint, Base, Tool | Fixed tool point |
| Types of Motion Control | | Joint/Linear, Circular Interpolated motion | |
| Programming | | Point to point teaching or language based programming | |
| Memory Capacity | | 8MB (Approx. 80,000 steps) | |
| General Purpose Signals | External Operation | Motor power Off, Hold | |
| | Input | 32 Channels | 128 Channels |
| | Output | 32 Channels | 128 Channels |
| Operation Panel | | E-Stop switch, teach/repeat switch, control power light (Cycle start, motor-on, hold/run, errors, and error reset are activated from the teach pendant.) | |
| Cable Length | Teach Pendant | 5 m | 5 m, 15 m, 20 m, 25 m |
| | Robot-Controller | 6 m | Possible to extend up to 40 m |
| Mass | | 120 Kg | |
| Power Requirements | E25 | AC200-220V ±10%, 50/60Hz, 3Φ, Max.10kVA | |
| | E27 | AC200-220V ±10%, 50/60Hz, 3Φ, Max.5.6kVA | |
| | | Class D ground (Standard for robots) Class A ground (for intrinsic explosion-proof safety circuit) | |
| Environmental Condition | | Ambient Temperature:0~45°C, Relative Humidity:35~85% (No dew, nor frost allowed) | |
| Body Color | | Munsell 10GY9/1 equivalent | |
| Teach Pendant | | TFT color LCD display with touch-panel, E-Stop switch, teach lock switch, deadman switch | |
| Auxiliary storage unit | | USB Memory | |
| Interface | | USB, Ethernet (100BASE-TX), RS232C | |

● System configuration diagram

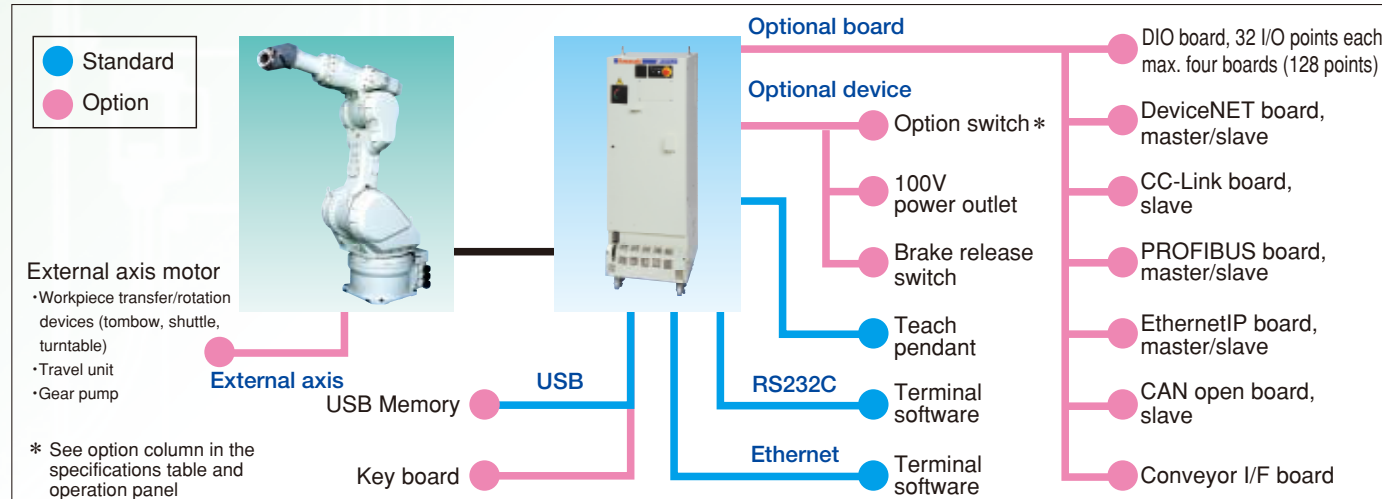

● Explosion-proof teach pendant

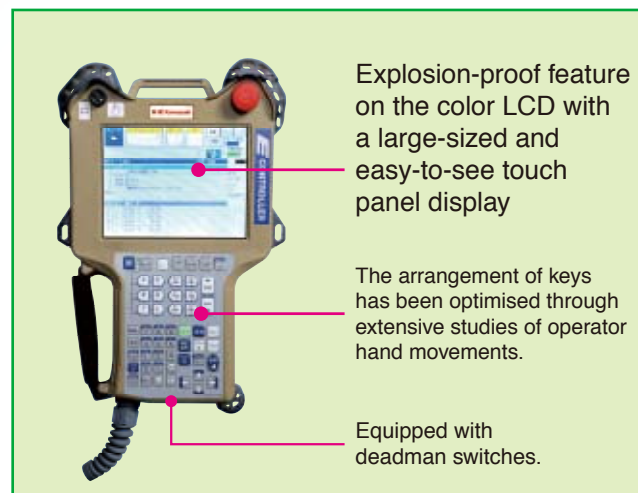

● External View and Dimensions E25/E27

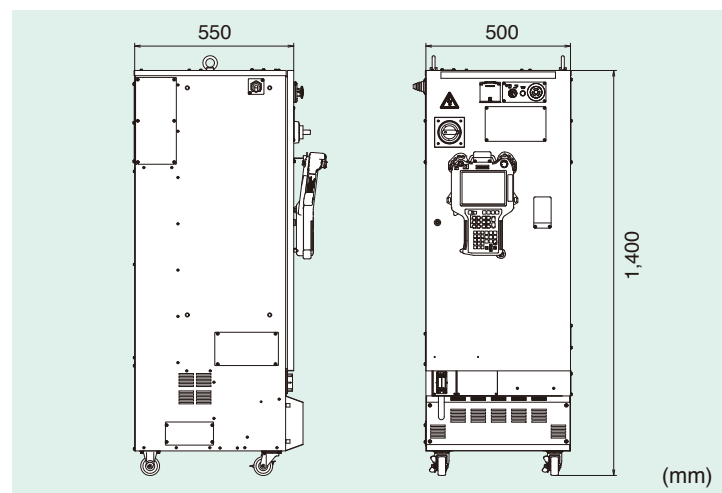

Peripheral Equipment

High quality, efficient spray painting can be achieved by combining high performance workpiece transfer and rotation devices, paint spray control systems of advanced technology and highly developed paint spray robots and atomizers.

Kawasaki's various types of peripheral equipment provide ideal paint spray facilities.

● Package Cells

To meet customer needs, we offer packaged cells that come in various sizes and configurations, these cells are named, servo twister, servo tombow, servo shuttle, servo spinner, servo turntable and servo wing.

● Painting unit control panel (air panel)

The painting unit control panel allows control of the changes to the discharge rate, atomizing air and air patterns to meet complex work applications.

Functions such as automatic color change and automatic washing for each specified cycle could be incorporated to suit the customers needs.

● Robot travel unit

Robot travel units synchronises robot operation with external servo drives, thus allowing the painting process to take place on a moving component. Robot travel units can be used during the painting of automobiles, construction machinery, and septic tanks.

● "KOSMOS" line control software

In painting processes where two or more robots are in operation, the KOSMOS line control panel provides real time status information and access to production management information.

● Line monitoring function

The LCD screen lets you observe the status of the entire system such as work-piece type, color, coating robot and peripheral unit operation, painting conditions, system errors etc.

● Data setting function

The graphical interface of the touch panel allows the setting and changing of the coating requirements and coating unit control panel.

• Paint flow rate, atomizing air pressure, pattern air pressure and the other painting requirement settings.

• Time chart setting for color change, gun cleaning etc.

• Program number setting for each work-piece type and color.

• CCV number setting for each color

● Statistical functions

Available data for production management include, production statistics, error statistics, paint consumption, etc.



Painting unit control panel

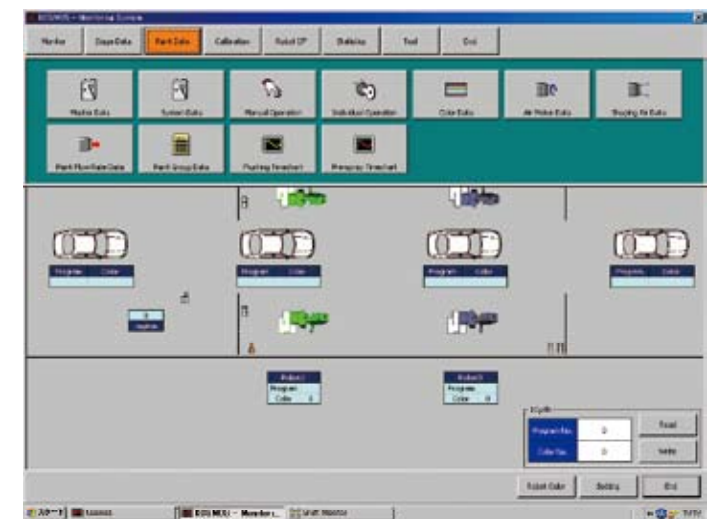

Line control panel

Small sized painting applications

Servo Twister

A compact but sophisticated system

Features

1. Small installation space

The minimum installation space required for this system is 2,200 mm wide x 1,966 mm long for a 600 x 600 mm table. Such compactness allows you to install this system in a narrow hand-blowing booth.

2. Rotary table functions

In spite of its small size the Servo Twister provides rotary coating, indexed coating and rotary synchronization functions.

3. 6-axis robots

The Servo Twister installation uses a 6-axis, articulated robot.

4. Shared coating program

The integration of the robot and painting table into one unit allows for programs to be shared by more than one robot.

5. Short installation time

The servo twister cell can be built before delivery, so that the installation time is as shortened and in production as soon as possible.

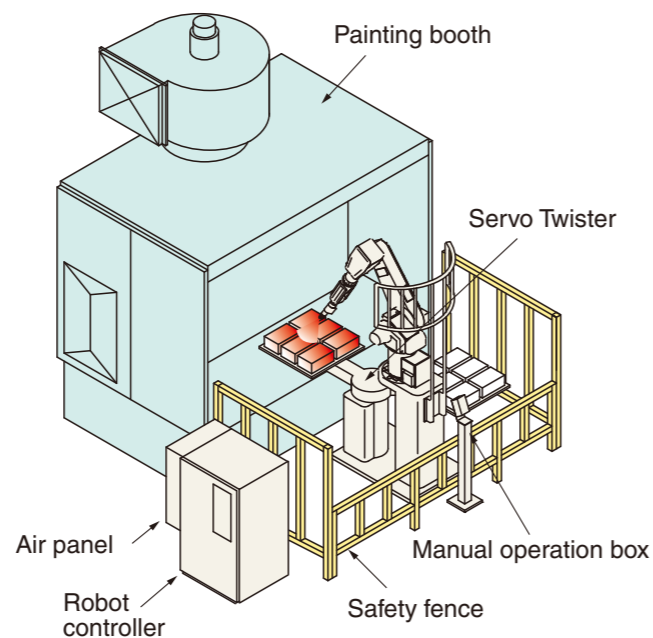

Specifications

| | | Standard |
|---------------------------|----------------------------|--|
| Table load | | 20 kg x 2 Table |
| No. of control axes | | Robot 6+Servo twister 2 |
| Control method | | Servo control |
| Teaching playback method | | PTP teaching+CP control |
| Position detection method | | Absolute encoder |
| Arm | Length | 650 mm, 800 mm |
| | Operation angle | 135° |
| | Indexing time | 1.8/135° |
| Table | Operation angle | Infinite revolution |
| | Indexing angle | 90-deg and arbitrary angle |
| | Indexing time | 0.8/90° |
| | Uninterrupted rotary speed | Max. 90 rpm |
| Rotary direction | | Normal/reverse rotation |
| Explosion protection | | Air pressurized explosion protection and intrinsically safe. Explosion-proof composite type (Expib IIBT4 / Exib IIBT4) |
| Mass | | 120 kg |
| Color | | Munsell 10GY9/1 equivalent |

Note : The work loading table and loading fixtures to be prepared by the purchaser.

External View and Dimensions

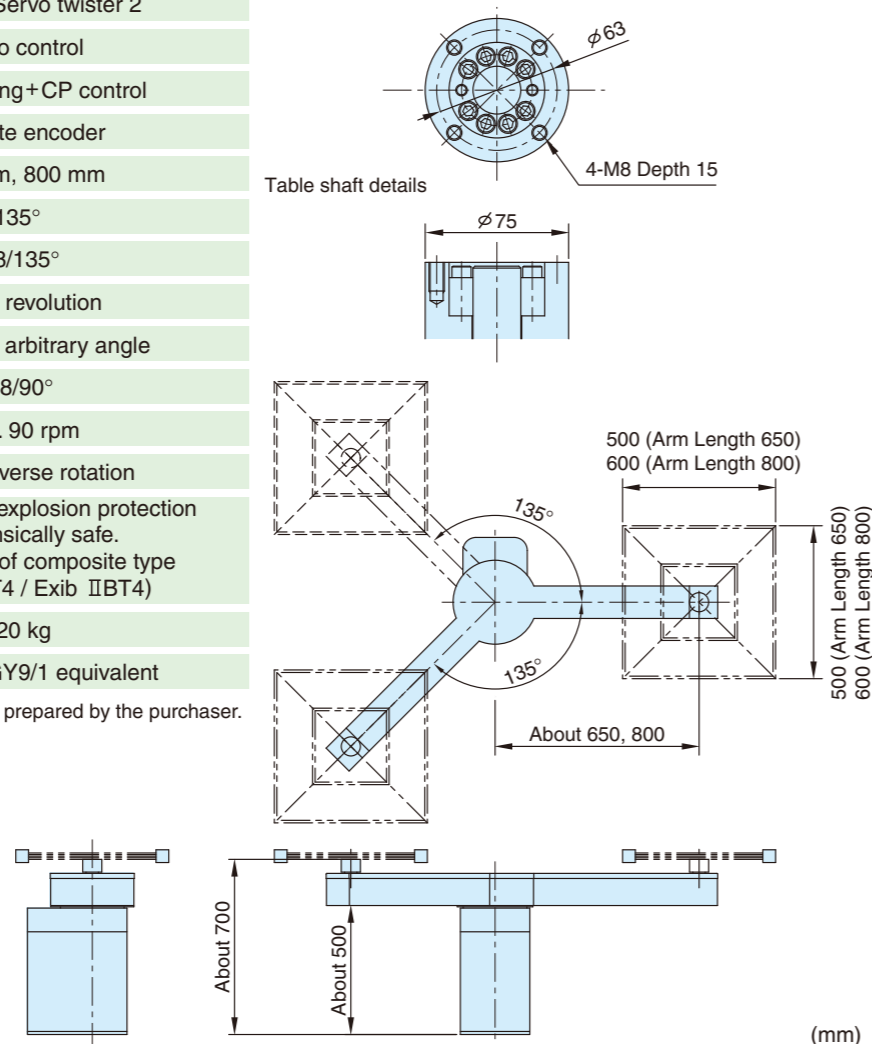

Small sized painting applications

Servo Tombow

Space saving and easy-to-install

Features

1. Smooth movement

Servo motion control provides smooth movement to eliminate work slippage.

2. Higher painting quality

For small cubical boxes (electronic appliances such as TV cabinets, etc.), the spray gun can be oriented to each surface at a right angle. The distance between the gun and the surface can also be adjusted simply by entering a value. These features enable easy operation and enhance the painting quality.

3. Synchronous operation with the robot

The Servo Tombow's table rotation is synchronized with the robot movements, assuring a uniform paint finish for cylindrical shaped components such as hot plates, wooden trays, automobile hubs etc. The Tombow table offers 360 degrees of rotation.

4. Preventing paint mist accumulation

To reduce the problem of paint mist accumulation, workpieces can be positioned above a water tank when spraying.

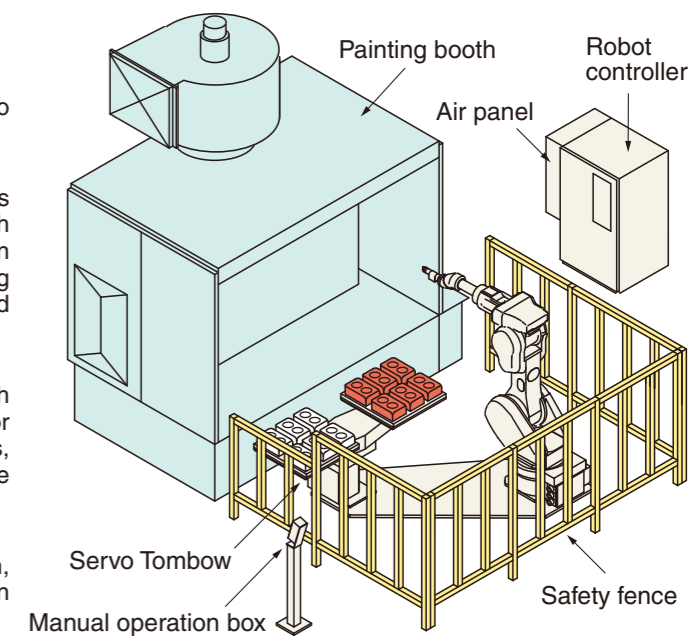

Specifications

| | | Standard | Heavy load carrying |
|---------------------------|----------------------------|--|---------------------|
| Table load | | 20 kg x 2 Table | 40 kg x 2 Table |
| No. of control axes | | Robot 6+Servo tombow 2 | |
| Control method | | Servo control | |
| Teaching playback method | | PTP teaching+CP control | |
| Position detection method | | Absolute encoder | |
| Arm | Diameter | 1,000 mm, 1,400 mm | |
| | Operation angle | 180° | |
| | Indexing time | 2/180° | |
| Table | Operation angle | Infinite revolution | |
| | Indexing angle | 90-deg and arbitrary angle | |
| | Indexing time | 0.8/90° | 1.2/90° |
| | Uninterrupted rotary speed | Max. 90 rpm | Max. 45 rpm |
| Rotary direction | | Normal/reverse rotation | |
| Explosion protection | | Air pressurized explosion protection and intrinsically safe. Explosion-proof composite type (Expib IIBT4 / Exib IIBT4) | |
| Mass | | 110 kg (Diameter: 1,000 mm), 150 kg (Diameter: 1,400 mm) | |
| Color | | Munsell 10GY9/1 equivalent | |

Note : The standard arm lengths are 1,000 mm and 1,400 mm.

The work loading table and loading fixtures to be prepared by the purchaser.

External View and Dimensions

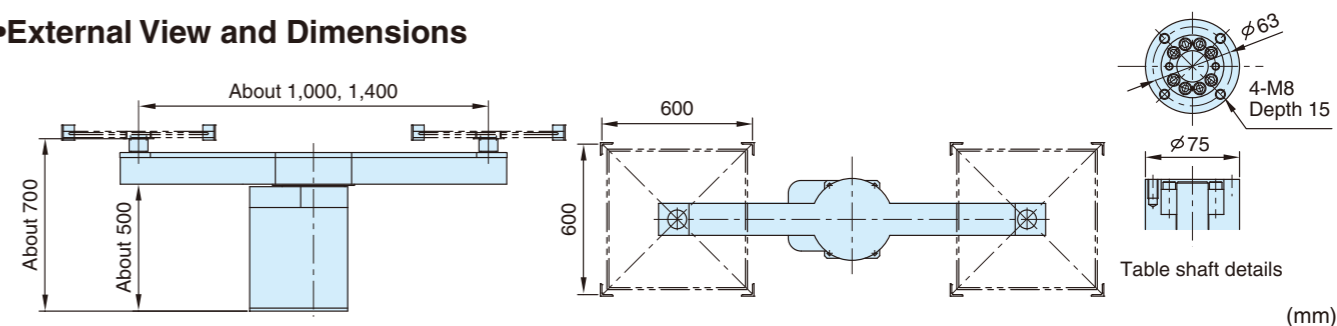

Medium sized work-piece painting cell

Servo Shuttle

Ultimate “table painting” type

Features

1. Improvement in productivity

Servo motion provides high speed work transfer and table rotation with shock-less smooth start and stop motion, and also enables continuous rotation tracking with robot and any stand-by position of feeder.

2. Higher coating quality

Controlling the position of the table provides the optimum painting position. This combined with the high-speed, high-precision robot with the servo shuttle enables high-quality painting.

3. Simple teaching

The simple teaching function provided by the KF series painting robot eliminates time-consuming program teaching.

4. Increased table load

The system can be used for painting large TV cabinets, sanitary ware, automobile instrument panels etc.

5. Simple installation

This complete package is simple to install, but will provide for the painting of the most complex of components.

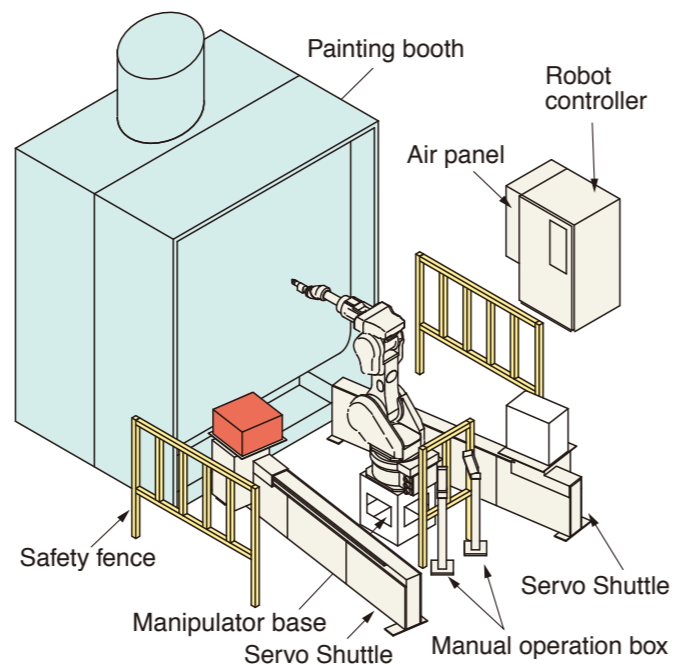

Specifications

| | | Standard | Heavy load carrying |
|----------------------------|----------------------------|--|----------------------------|
| Table load | | 20 kg x 2 Table | 60kg x 2 Table |
| No. of control axes | | Robot 6+ Servo shuttle 2 | |
| Control method | | Servo control | |
| Teaching playback method | | PTP teaching+CP control | |
| Position detection method | | Absolute encoder | |
| Shuttle | Stroke | 2,000 mm, 2,700 mm, 3,200 mm, 4,000 mm | |
| | Max. speed | 1,000 mm/sec | |
| Table | Operation angle | Infinite revolution | |
| | Indexing angle | 90-deg and arbitrary angle | |
| | Indexing time | 0.8/90° | 1.2/90° |
| | Uninterrupted rotary speed | Max. 90 rpm | Max. 45 rpm |
| Rotary direction | | Normal/reverse rotation | |
| Intermediate stop function | | The intermediate stop function and multiple coating control function are available. | |
| Explosion protection | | Air pressurized explosion protection and intrinsically safe. Explosion-proof composite type (Expib II BT4 / Exib II BT4) | |
| Mass | | One side: 230 kg to 310 kg | One side: 350 kg to 405 kg |
| Color | | Munsell 10GY9/1 equivalent | |

Note : The work loading table and loading fixtures to be prepared by the purchaser.

External View and Dimensions

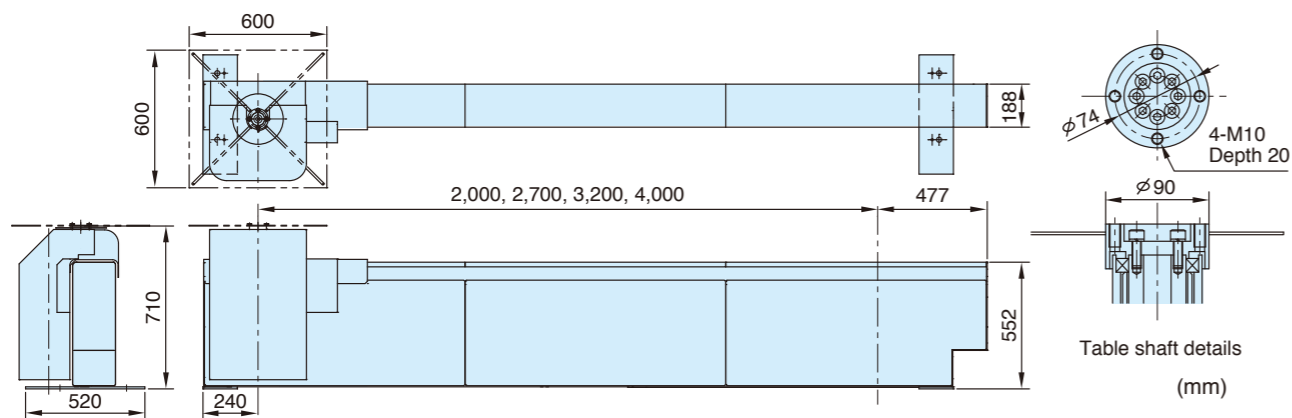

Medium sized work-piece painting cell

Servo Wing

The installation space for “Table Painting” was made even smaller.

Features

1. Space Saving

While suitable for workpieces of a larger size than in the Servo Shuttle, the installation space is made smaller. Because the left and right workpieces are closer together, loading and unloading work is reduced.

2. Even Small-sized Robots Cope with Large Work-pieces.

Because there is one painting position, the distance between the workpiece and the robot becomes closer, making the robot possibly smaller than that in Servo Shuttle.

3. Less teaching work

Because the left and right arms can be set for the same painting positions (one position), a single program can be used, thus making the teaching time shorter.

4. Preventing paint mist accumulation

Because the arms are slim with no fixed rails, painting can be conducted above the water, reducing soiling of the booth. In addition, the airflow turbulence inside the paint booth can be minimized.

5. Short Construction Period

This device is delivered pre-assembled. So, it can be installed in as little as one day and you can start production immediately.

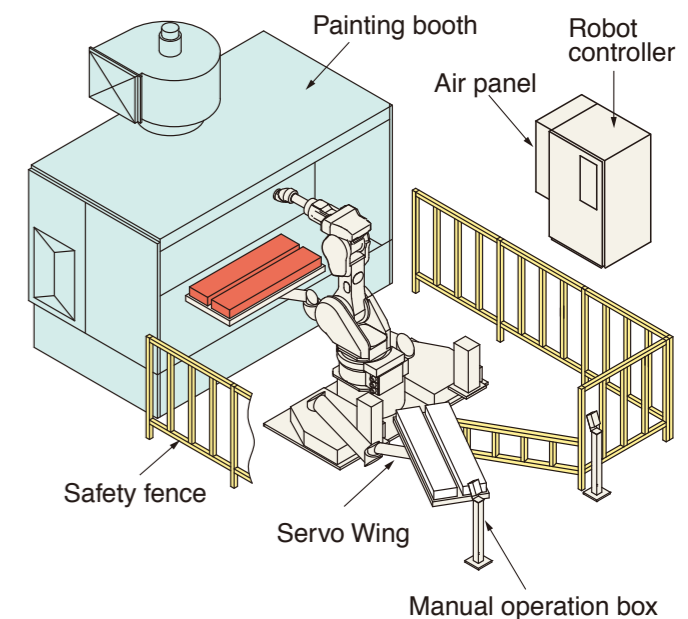

External View and Dimensions

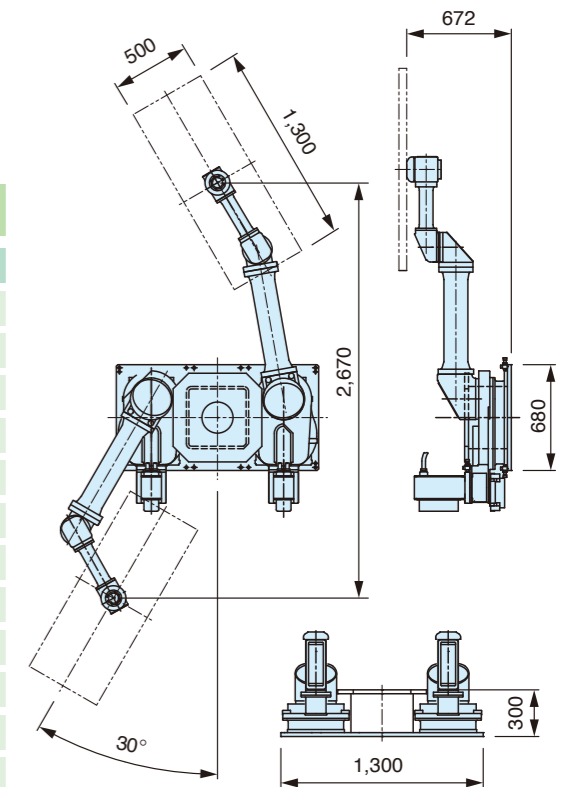

Specifications

| | | Standard |
|----------------------------|----------------------------|--|
| Table load | | 30 kg x 2 Table |
| No. of control axes | | Robot 6+ Servo wing 2 |
| Control method | | Servo control |
| Teaching playback method | | PTP teaching+CP control |
| Position detection method | | Absolute encoder |
| Arm | Stroke | 2,670mm |
| | Max. speed | 540° mm/sec |
| Table | Operation angle | Infinite revolution |
| | Indexing angle | 90-deg and arbitrary angle |
| | Indexing time | 1.2/90° |
| | Uninterrupted rotary speed | Max. 90 rpm |
| Rotary direction | | Normal/reverse rotation |
| Intermediate stop function | | The intermediate stop function and multiple coating control function are available. |
| Explosion protection | | Air pressurized explosion protection and intrinsically safe. Explosion-proof composite type (Expib BT4 / Exib BT4) |
| Mass | | 970kg |
| Color | | Munsell 10GY9/1 equivalent |

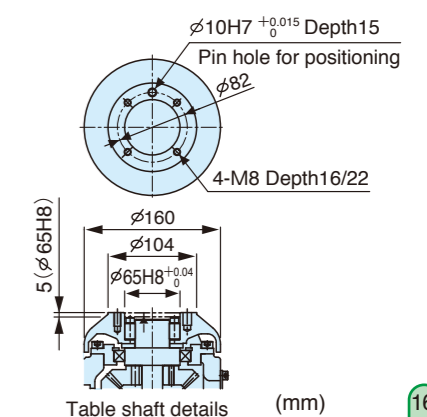

Medium sized work-piece painting cell

Servo Spinner

A new dimension in "line coating"

Features

- 1. Flexible component placement**
Choose the optimum painting posture for the workpiece, and reduce contamination of the paint booth.
- 2. Uninterrupted painting**
Painting can be performed with the table rotating, thus minimizing the robot's wait time.

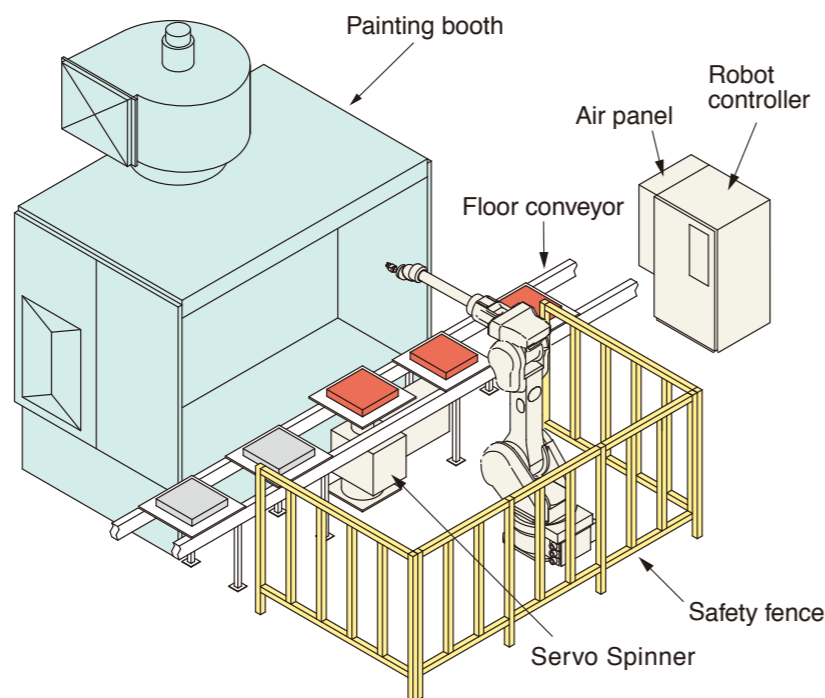

Specifications

| | Standard | Heavy load carrying |
|---------------------------|----------------------------|---------------------|
| Table load | 20 kg | 60 kg |
| No. of control axes | Robot 6+Servo Spinner 1 | |
| Control method | Servo control | |
| Teaching playback method | PTP teaching+CP control | |
| Position detection method | Absolute encoder | |
| Table | Operation angle | |
| | Indexing angle | |
| | 0.8/90° | 1.1/90° |
| | Max. 90 rpm | Max. 45 rpm |
| Rotary direction | | |
| Explosion protection | | |
| Mass | 60 kg | |
| Color | Munsell 10GY9/1 equivalent | |

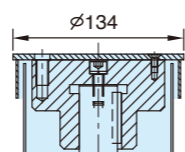
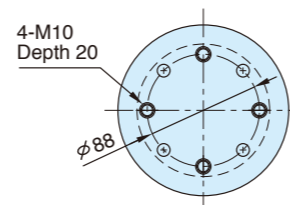
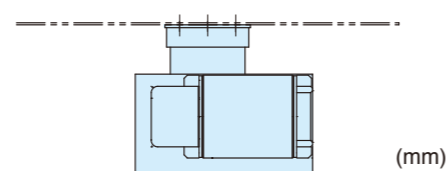
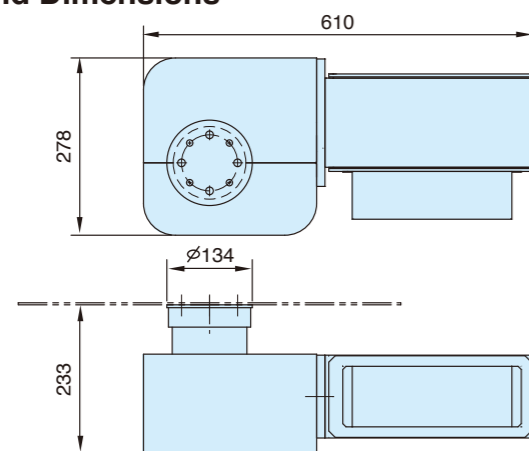

Table shaft details

External View and Dimensions



(mm)

Large sized work-piece painting cell

Servo Turntable

Complete surface painting is possible with uninterrupted turntable rotation

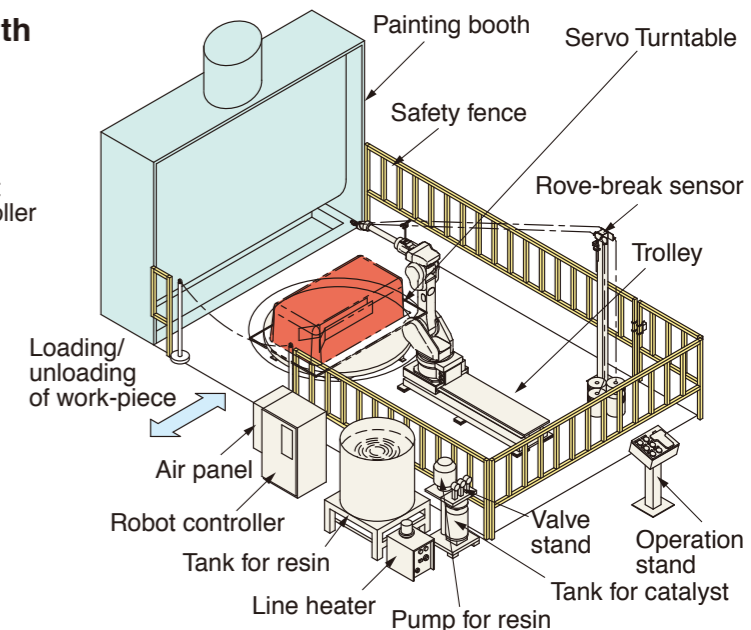
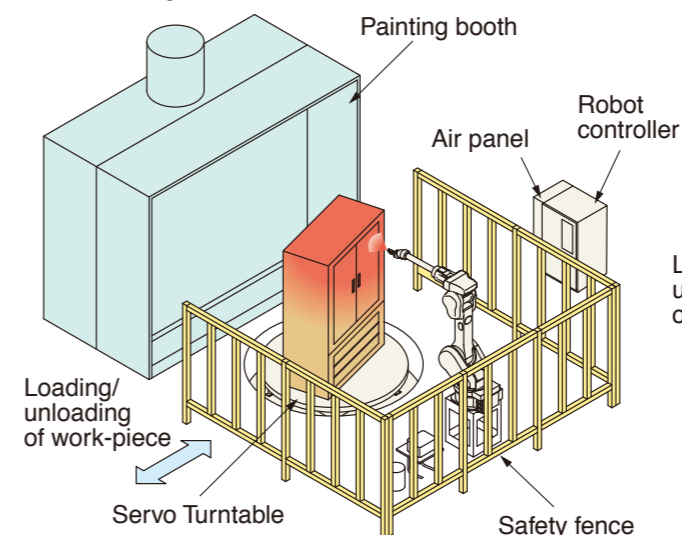

Standard System

- The integrated control of the robot and table allows any painting position to be achieved according to the work shape.
- The system can be applied to various types of painting such as synchronous control, arbitrary-angle indexing, paint spraying with continuous rotation of the table.

FRP System

- The travel unit further enlarges the work envelope of the robot's already large motion range. You can paint large or long workpieces such as furniture, vending machines, bathtubs, etc.
- Kawasaki offers a total package including the FRP spray-up unit and roving shortage detection unit.

Specifications

| | Standard | Heavy load carrying |
|-------------------------------|--|--|
| Table load | Max. 500 kg | Max. 1,000 kg |
| No. of control axes | Robot 6+Servo Turntable 1 | |
| Control method | Servo control | |
| Teaching playback method | PTP teaching+CP control | |
| Position detection method | Absolute encoder | |
| Table | Operation angle | |
| | Indexing angle | |
| | 90-deg and arbitrary angle | 45-deg., 90-deg., 180-deg and arbitrary angle |
| | 2.5/90° | 5/90° |
| Uninterrupted rotary speed | | |
| Rotary direction | | |
| Explosion protection | | |
| Mass | 510 kg | 560 kg |
| Table | Diameter | |
| | 450 mm | |
| Color | | |
| Munsell 10GY9/1 equivalent | | |
| Foot switch function (Option) | Uninterrupted normal rotation, rotation stop | Uninterrupted rotation, 45-deg., 90-deg., 180-deg. indexing (changeable indexing angle), rotation stop |

External View and Dimensions

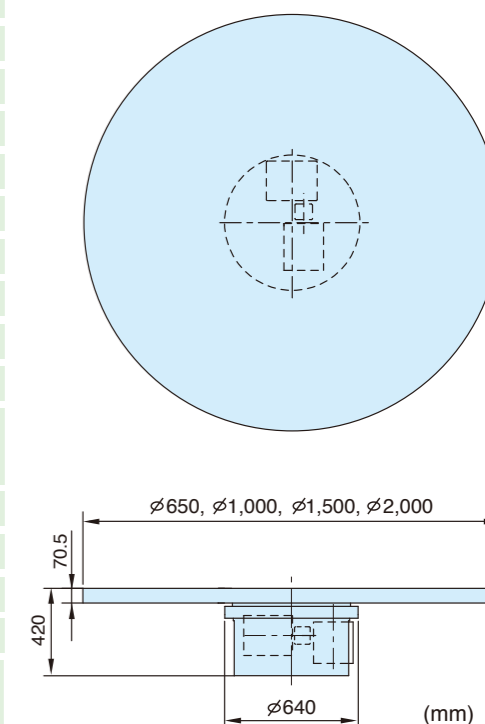

(mm)