

- ▶ Electronic motor brake
- ▶ No additional braking accessory required
- ▶ Integrated brake contactor
- ▶ Brake contactor switches after de-energization
- ▶ Integrated motor contactor control
- ▶ Industrial design



## Technical data

### 1. Functions

Electronic motor brake for asynchronous motors without additional mechanical accessory.  
 Integrated brake contactor  
 Activation of motor contactor integrated  
 Connection of external brake contactor possible  
 Brake contactor switches after de-energization

### 2. Time ranges

Braking time:	Adjustment range	
MBG 10	0s	30s
MBG 20 and 35	0s	40s

### 3. Indicators

LED U: supply voltage applied  
 Green LED (Start) ON: indication brake activated  
 Yellow LED ON: current limitation active (MBG20 and MBG35 only)

### 4. Mechanical design

Self-extinguishing plastic housing, IP rating IP40  
 Mounted on DIN-Rail TS 35 according to EN 50022  
 Mounting position: heat sink on top  
 Shockproof terminal connections according to VBG 4, IP rating IP20

Control circuit:  
 Terminal capacity:  
 1 x 0.5 to 2.5mm<sup>2</sup> with/without multicore cable end  
 1 x 4mm<sup>2</sup> without multicore cable end  
 2 x 0.5 to 1.5mm<sup>2</sup> with/without multicore cable end  
 2 x 2.5mm<sup>2</sup> flexible without multicore cable end  
 Initial torque: 0.5Nm

Power circuit:  
 Terminal capacity: according to power class

### 5. Control circuit

Supply voltage: generated internally  
 Tolerance: -  
 Rated frequency: -  
 Duration of operation: 100%

### 6. Control input 1-2

Function: activation of brake  
 Loadable: No  
 Line length: max. 10m, twisted pair  
 Control pulse length: min. 0.2s

### 7. Control input 3-4

Function: lock of power circuit  
 Loadable: No  
 Line length: max. 10m, twisted pair  
 Control pulse length: min. 0.2s

### 8. Control contact 5-6

1 potential free normally open contact  
 Function: connection of additional brake contactor (e.g. for extended contactor interlock)  
 Switching capacity: 750VA (3A / 250V AC)  
 Fusing: 3A

### 9. Control contact 6-7

1 potential free normally closed contact  
 Function: connection of motor contactor  
 Switching capacity: 750VA (3A / 250V AC)  
 Fusing: 3A

### 10. Power circuit

**MBG10:**  
 Control voltage: 1~ 230V terminals L1-N  
 Tolerance: ±10%  
 Rated frequency: 48 to 63Hz  
 Current limitation: no  
 Braking cycles: 30/hour (5s and braking current 10A)  
 10/hour (t<sub>max</sub> and braking current 10A)  
 Rated surge voltage: 2.5kV (according to IEC 60947-1/DIN VDE 0110 part1)  
 Insulation voltage: 345/600V (according to IEC60947-1, 4.3.1.2)

### MBG20 and MBG35:

Control voltage: 2~ 400V terminals L1-L2  
 Tolerance: ±10%  
 Rated frequency: 48 to 63Hz  
 Current limitation I<sub>max</sub>: 20A MBG20  
 35A MBG35  
 Braking cycles: 30/hour (5s and I<sub>max</sub>)  
 10/hour (t<sub>max</sub> and I<sub>max</sub>)  
 Rated surge voltage: 2.5kV (according to IEC 60947-1/DIN VDE 0110 part1)  
 Insulation voltage: 345/600V (according to IEC60947-1, 4.3.1.2)

### 11. Power classes

(see table on next page)

### 12. Ambient conditions

Ambient temperature: -25 to +55°C (according IEC 68-1)  
 Storage temperature: -25 to +70°C  
 Transport temperature: -25 to +70°C  
 Relative humidity: 5% to 95% not condensing  
 Pollution degree: 2 (according to IEC 664-1)

### 13. Accessories

Sealable cover protecting unit against unknowingly or unauthorised modification of adjusted parameters

## Technical data

### ref. to 9. Power classes

Type	recommended for drives up to (kW)	max. rated braking current (A)	current limitation (A)	weight (g)
MBG 10	2.2	10	no	290
MBG 20	5.5	20	yes, 20	510
MBG 35	11.0	35	yes, 35	680

All values refer to standardised motors according to IEC 72 and UNE 20106. The actually needed braking current refers to the application and has to be ascertained by the customer. Therefore it might be necessary to choose a larger motor brake than mentioned in the table above.

## Functions

### DC-braking of a motor

Closing the start contact activates the motor brake. In doing this the motor contactor is opened and the brake contactor is closed. After a short delay a DC-current (rectified via a thyristor using phase angle control) is sent through the motor coil. This current can be adjusted via the  $t_{brake}$  regulator.

The maximum value of this current is limited by the serial connection of motor coil, supply voltage and the thyristor. Please note that the resistance of the thyristor can be almost reduced to  $0\Omega$  (equivalent to  $100\% I_{brake}$ ).

The current in the motor coil induces a magnetic field within the stator. The rotor attempts to follow this field and is thus slowed down by the speed-dependent braking torque created within the time adjusted at the  $t_{brake}$  regulator. After the interval  $t_{brake}$  has expired first the braking current is switched off and then the brake contactor is de-energised. This course of actions avoids the loss of contact material of the contactor caused by an arc-over.

After deactivating the brake contactor the motor contactor is enabled again.

It is a fact that the information necessary to exactly calculate the braking torque or braking current  $I_{brake}$  and the braking time  $t_{brake}$  is hardly known for the drive system and for all occurring moments of inertia. The necessary braking torque should therefore be recorded on-site during a test run. Please note that the coil resistance continuously changes until the motor has reached the operating temperature.

As a result of this way of braking no current is induced inside the rotor when the motor has stopped. The motor therefore has no holding torque.

### Current limitation

Because the motor brake MBG10 has no emergency shutoff or safety limitations it can happen that the device is damaged by high braking currents. Therefore it is necessary that during a first test run the braking current is increased slowly and does not exceed the maximum braking current of 10A. The braking current has to be monitored with a measuring device during this test run.

For both types the MBG20 and the MBG35 the device is protected against high braking currents. If the actual current exceeds the nominal current the LED "Current limitation active" is illuminated and the current is limited to the nominal current.

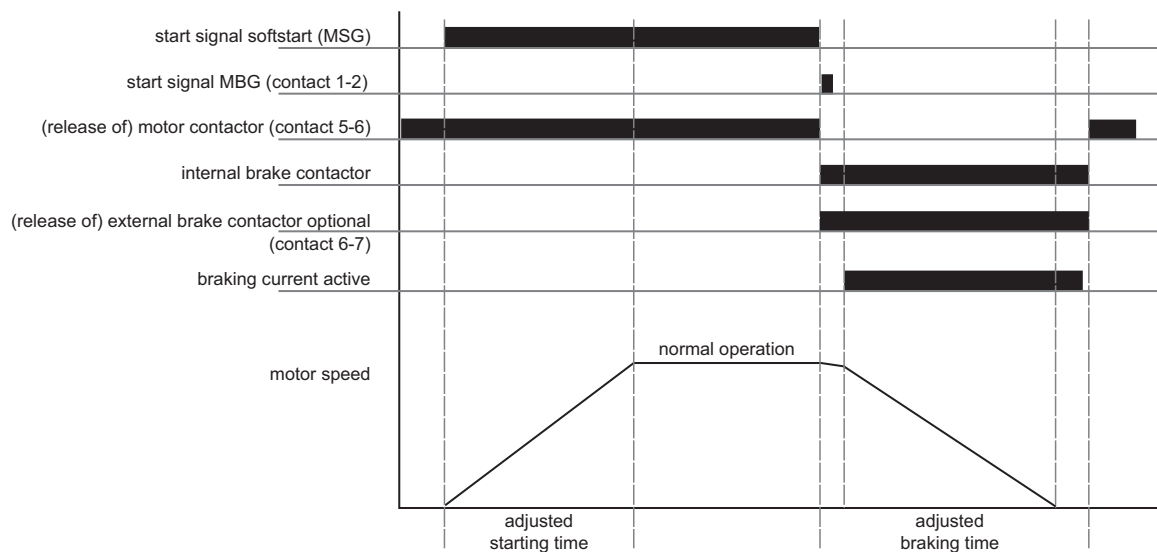

Timing sequence for one working cycle including softstart (e.g. with MSG) and braking with MBG

# Connections

## ► Example of standard wiring for MBG10

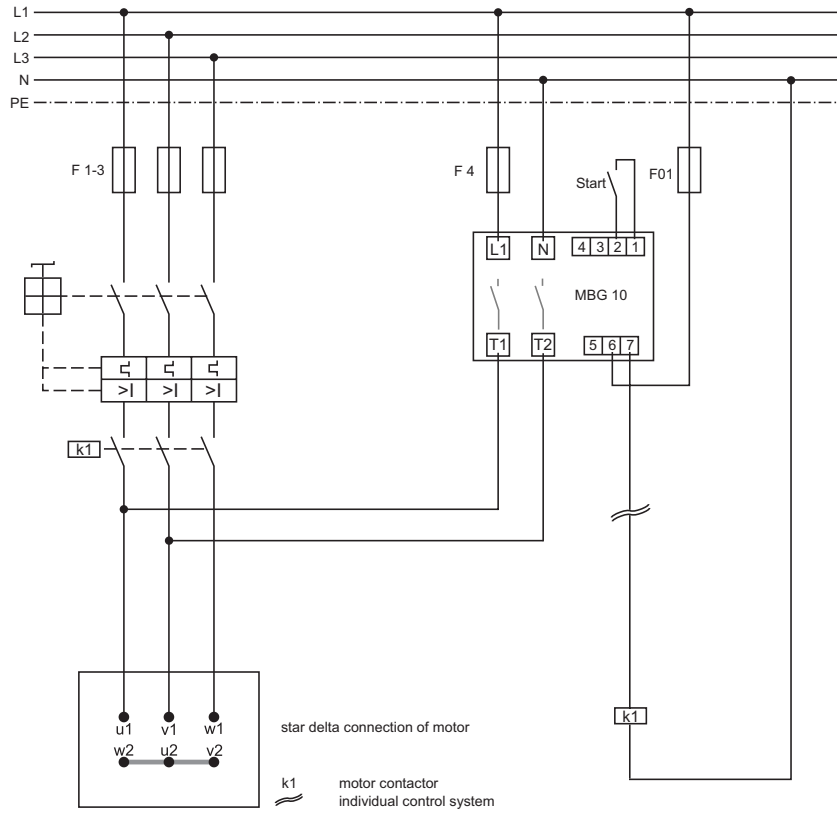

## ► Extended wiring for MBG20 and softstarter (e.g. MSG)

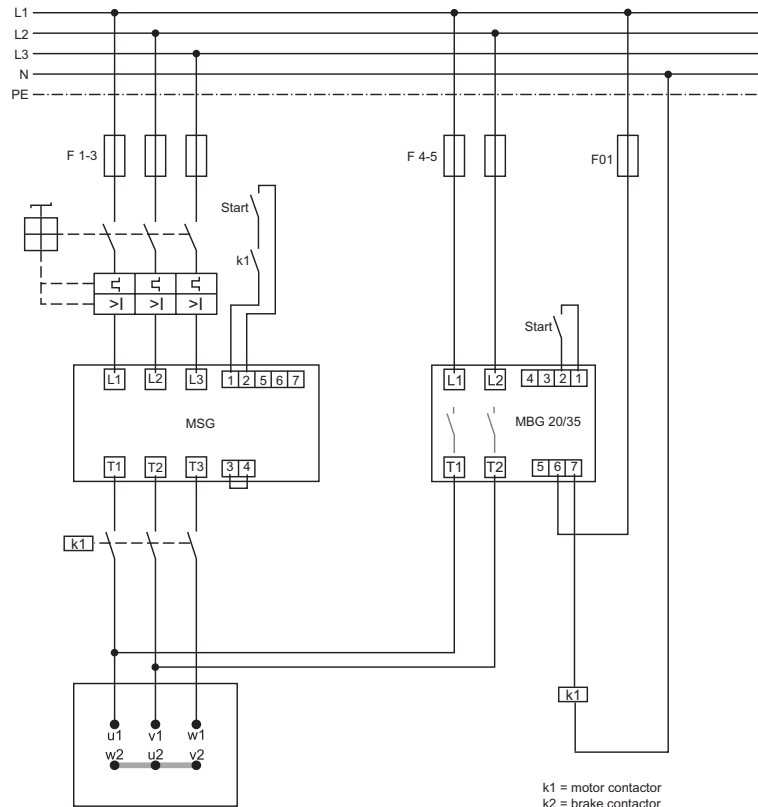

## Dimensions

### MBG10

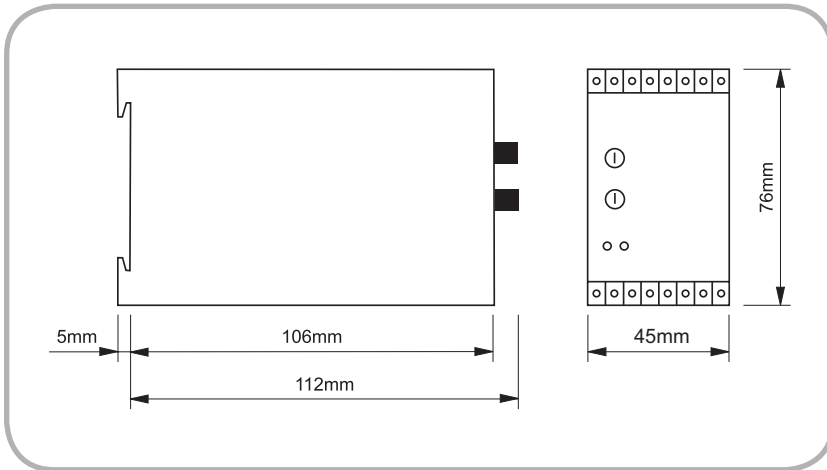

### MBG20

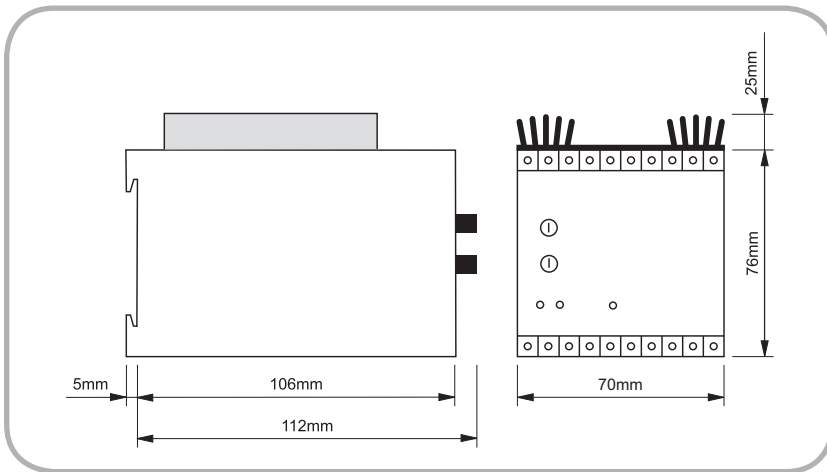

### MBG35

