

- ▶ AC/DC voltage monitoring in 1-phase mains
- ▶ Multifunction
- ▶ 16.6 to 400Hz
- ▶ Fault latch
- ▶ Zoom voltage 24 to 240V AC/DC
- ▶ 2 change-over contacts
- ▶ Width 22.5mm
- ▶ Industrial design



Technical data

1. Functions

AC/DC voltage monitoring in 1-phase mains with adjustable thresholds, timing for start-up suppression and tripping delay separately adjustable, fault latch and the following functions (selectable by means of rotary switch)

OVER	Overvoltage monitoring
OVER+LATCH	Overvoltage monitoring with fault latch
UNDER	Undervoltage monitoring
UNDER+LATCH	Undervoltage monitoring with fault latch
WIN	Monitoring the window between Min and Max
WIN+LATCH	Monitoring the window between Min and Max with fault latch

2. Time ranges

	Adjustment range	
Start-up suppression time:	0s	10s
Tripping delay:	0.1s	10s

3. Indicators

Green LED ON:	indication of supply voltage
Green LED flashing:	indication of start-up suppression time
Yellow LED ON/OFF:	indication of relay output
Red LED ON/OFF:	indication of failure of the corresponding threshold
Red LED flashing:	indication of tripping delay of the corresponding threshold

4. Mechanical design

Self-extinguishing plastic housing, IP rating IP40
 Mounted on DIN-Rail TS 35 according to EN 50022
 Mounting position: any
 Shockproof terminal connection according to VBG 4 (PZ1 required), IP rating IP20
 Tightening torque: max. 1Nm
 Terminal capacity:
 1 x 0.5 to 2.5mm² with/without multicore cable end
 1 x 4mm² without multicore cable end
 2 x 0.5 to 1.5mm² with/without multicore cable end
 2 x 2.5mm² flexible without multicore cable end

5. Input circuit

Supply voltage:
 24 to 240V AC/DC terminals A1-A2 (galvanically separated)
 Tolerance:
 24 to 240V DC -20% to +25%
 24 to 240V AC -15% to +10%
 Rated frequency:
 24 to 240V AC 48 to 400Hz
 48 to 240V AC 16 to 48Hz
 Rated consumption: 4.5VA (1W)
 Duration of operation: 100%
 Reset time: 500ms
 Wave form for AC: Sinus
 Residual ripple for DC: 10%
 Drop-out voltage: >15% of the supply voltage
 Overvoltage category: III (according to IEC 60661-1)
 Rated surge voltage: 4kV

6. Output circuit

2 potential free change-over contacts
 Rated voltage: 250V AC
 Switching capacity (distance <5mm): 750VA (3A / 250V AC)
 Switching capacity (distance >5mm): 1250VA (5A / 250V AC)
 Fusing: 5A fast acting
 Mechanical life: 20 x 10⁶ operations
 Electrical life: 2 x 10⁵ operations at 1000VA resistive load
 max. 60/min at 100VA resistive load
 max. 6/min at 1000VA resistive load (according to IEC 947-5-1)
 Switching frequency:
 max. 60/min at 100VA resistive load
 max. 6/min at 1000VA resistive load (according to IEC 947-5-1)
 Overvoltage category: III (according to IEC 60664-1)
 Rated surge voltage: 4kV

7. Measuring circuit

Fusing: max. 20A (according to UL 508)
 Measured variable: DC or AC Sinus (16.6 to 400Hz)
 Input:
 30V AC/DC terminals E-F1(+)
 60V AC/DC terminals E-F2(+)
 300V AC/DC terminals E-F3(+)
 Overload capacity:
 30V AC/DC 100V_{eff}
 60V AC/DC 150V_{eff}
 300V AC/DC 440V_{eff}
 Input resistance:
 30V AC/DC 47kΩ
 60V AC/DC 100kΩ
 300V AC/DC 470kΩ
 Switching threshold
 Max: 10% to 100% of U_N
 Min: 5% to 95% of U_N
 Overvoltage category: III (according to IEC 60664-1)
 Rated surge voltage: 4kV

8. Accuracy

Base accuracy: ±5% (of maximum scale value)
 Frequency response: -10% to +5% (at 16.6 to 400Hz)
 Adjustment accuracy: ≤5% (of maximum scale value)
 Repetition accuracy: ≤2%
 Voltage influence: ≤0.5%
 Temperature influence: ≤0.1% / °C

9. Ambient conditions

Ambient temperature: -25 to +55°C (according to IEC 68-1)
 -25 to +40°C (according to UL 508)
 Storage temperature: -25 to +70°C
 Transport temperature: -25 to +70°C
 Relative humidity: 15% to 85%
 (according to IEC 721-3-3 class 3K3)
 Pollution degree: 3 (according to IEC 60664-1)
 Vibration resistance: 10 to 55Hz 0.35mm
 (according to IEC 68-2-6)
 Shock resistance: 15g 11ms (according to IEC 68-2-27)

Functions

When the supply voltage U is applied, the output relays switch into on-position (yellow LED illuminated) and the set interval of the start-up suppression (START) begins (green LED U flashes). Changes of the measured voltage during this period do not affect the state of the output relay. After the interval has expired the green LED is illuminated steadily.

For all the functions the LEDs MIN and MAX are flashing alternating, when the minimum value for the measured voltage was chosen to be greater than the maximum value.

Overvoltage monitoring (OVER, OVER+LATCH)

When the measured voltage exceeds the value adjusted at the MAX-regulator, the set interval of the tripping delay (DELAY) begins (red LED MAX flashes). After the interval has expired (red LED MAX illuminated), the output relays switch into off-position (yellow LED not illuminated). The output relays again switch into on-position (yellow LED illuminated), when the measured voltage falls below the value adjusted at the MIN-regulator (red LED MAX not illuminated).

If the fault latch is activated (OVER+LATCH) and the measured voltage remains above the MAX-value longer than the set interval of the tripping delay, the output relays remain in the off-position even if the measured voltage falls below the value adjusted at the MIN-regulator. After resetting the failure (interrupting and re-applying the supply voltage), the output relays switch into on-position and a new measuring cycle begins with the set interval of the start-up suppression (START).

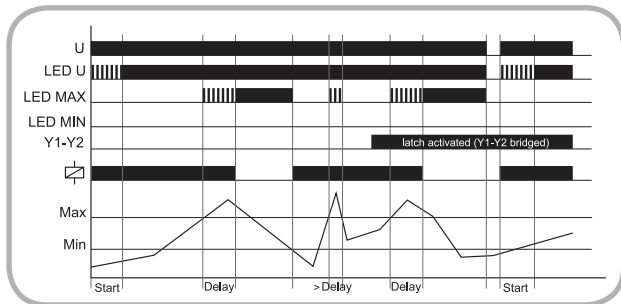

Undervoltage monitoring (UNDER, UNDER+LATCH)

When the measured voltage falls below the value adjusted at the MIN-regulator, the set interval of the tripping delay (DELAY) begins (red LED MIN flashes). After the interval has expired (red LED MIN illuminated), the output relays switch into off-position (yellow LED not illuminated). The output relays again switch into on-position (yellow LED illuminated), when the measured voltage exceeds the value adjusted at the MAX-regulator.

If the fault latch is activated (UNDER+LATCH) and the measured voltage remains below the MIN-value longer than the set interval of the tripping delay, the output relays remain in the off-position even if the measured voltage exceeds the value adjusted at the MAX-regulator. After resetting the failure (interrupting and re-applying the supply voltage), the output relays switch into on-position and a new measuring cycle begins with the set interval of the start-up suppression (START).

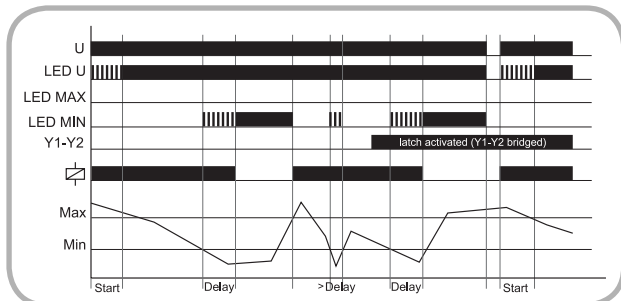

Window function (WIN, WIN+LATCH)

The output relays switch into on-position (yellow LED illuminated) when the measured voltage exceeds the value adjusted at the MIN-regulator. When the measured voltage exceeds the value adjusted at the MAX-regulator, the set interval of the tripping delay (DELAY) begins (red LED MAX flashes). After the interval has expired (red LED MAX illuminated), the output relays switch into off-position (yellow LED not illuminated). The output relays again switch into on-position (yellow LED illuminated) when the measured voltage falls below the value adjusted at the MAX-regulator (red LED MAX not illuminated). When the measured voltage falls below the value adjusted at the MIN-regulator, the set interval of the tripping delay (DELAY) begins again (red LED MIN flashes). After the interval has expired (red LED MIN illuminated), the output relays switch into off-position (yellow LED not illuminated).

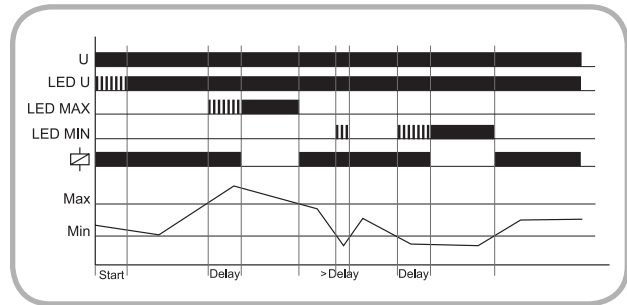

If the fault latch is activated (WIN+LATCH) and the measured voltage remains below the MIN-value longer than the set interval of the tripping delay, the output relays remain in the off-position even if the measured voltage exceeds the value adjusted at the MIN-regulator. If the measured voltage remains above the MAX-value longer than the set interval of the tripping delay, the output relays remain in the off-position even if the measured voltage falls below the value adjusted at the MAX-regulator. After resetting the failure (interrupting and re-applying the supply voltage), the output relays switch into on-position and a new measuring cycle begins with the set interval of the start-up suppression (START).

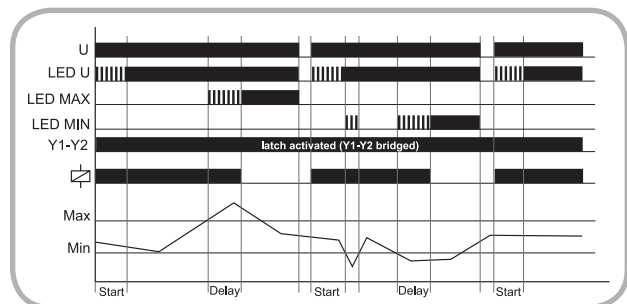

Connections

Range 30V, supply voltage 24V AC/DC and fault latch

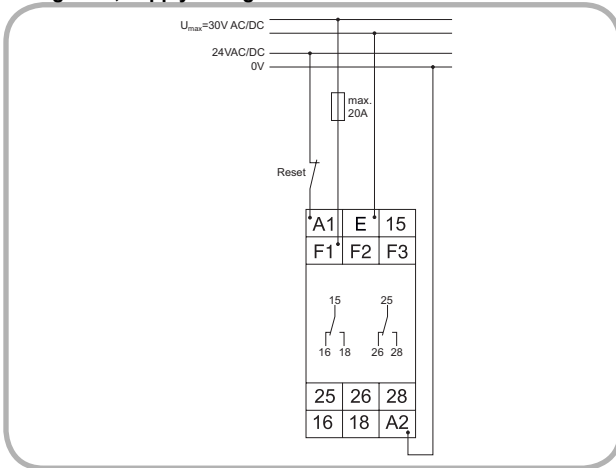

Range 60V, supply voltage 230V AC and fault latch

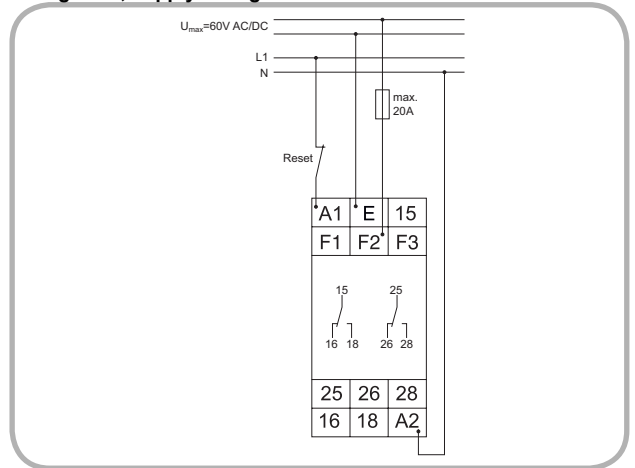

Range 300V, supply voltage 24V AC/DC and fault latch

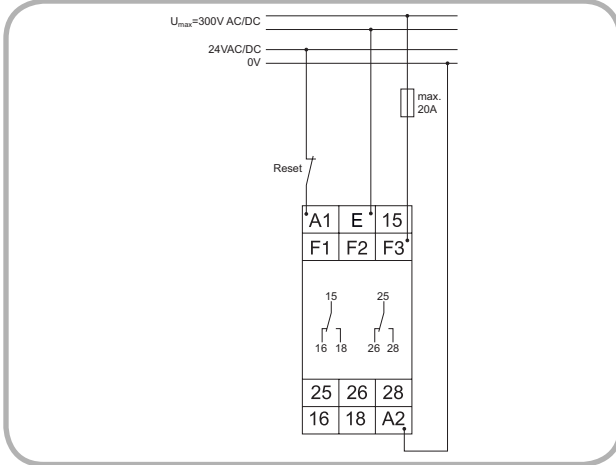

Subject to alterations and errors

Dimensions

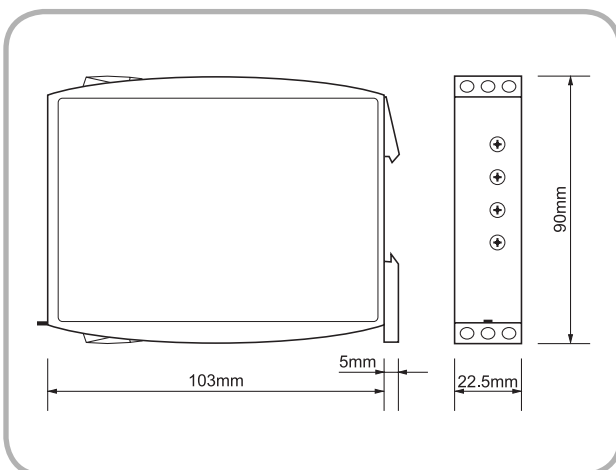

G2UM300VL20 24-240V

 **Notes**

Subject to alterations and errors