

- Temperature monitoring of the motor winding
- Short circuit monitoring of thermistor line
- Zero-voltage latch
- Zoom voltage 24 to 240V AC/DC
- 2 change-over contacts
- External reset key connectable
- Width 22.5mm
- Industrial design



## Technical data

### 1. Functions

Temperature monitoring of the motor winding (max. 6 PTC) with fault latch, for temperature probes in accordance with DIN 44081, test function with integrated test/reset key and the following additional functions (selectable by means of rotary switch)

Off	Basic function
+K	Short circuit monitoring of thermistor line
+N	Zero-voltage latch
+K+N	Short circuit monitoring and zero-voltage latch

### 2. Time ranges

	Adjustment range
Start-up suppression time:	-
Tripping delay:	-

### 3. Indicators

Green LED ON:	indication of supply voltage
Yellow LED ON/OFF:	indication of relay output
Red LED ON/OFF:	indication of failure

### 4. Mechanical design

Self-extinguishing plastic housing, IP rating IP40  
 Mounted on DIN-Rail TS 35 according to EN 50022  
 Mounting position: any  
 Shockproof terminal connection according to VBG 4 (PZ1 required), IP rating IP20  
 Tightening torque: max. 1Nm  
 Terminal capacity:  
 1 x 0.5 to 2.5mm<sup>2</sup> with/without multicore cable end  
 1 x 4mm<sup>2</sup> without multicore cable end  
 2 x 0.5 to 1.5mm<sup>2</sup> with/without multicore cable end  
 2 x 2.5mm<sup>2</sup> flexible without multicore cable end

### 5. Input circuit

Supply voltage:	24 to 240V AC/DC	terminals A1-A2 (galvanically separated)
Tolerance:	24 to 240V DC	-20% to +25%
	24 to 240V AC	-15% to +10%
Rated frequency:	24 to 240V AC	48 to 400Hz
	48 to 240V AC	16 to 48Hz
Rated consumption:		4.5VA (1W)
Duration of operation:		100%
Reset time:		500ms
Wave form for AC:		Sinus
Residual ripple for DC:		10%
Drop-out voltage:		>15% of the supply voltage
Overvoltage category:		III (according to IEC 60661-1)
Rated surge voltage:		4kV

### 6. Output circuit

2 potential free change-over contacts	
Rated voltage:	250V AC
Switching capacity (distance <5mm):	750VA (3A / 250V AC)
Switching capacity (distance >5mm):	1250VA (5A / 250V AC)
Fusing:	5A fast acting
Mechanical life:	20 x 10 <sup>6</sup> operations
Electrical life:	2 x 10 <sup>5</sup> operations
	at 1000VA resistive load
Switching frequency:	max. 60/min at 100VA resistive load
	max. 6/min at 1000VA resistive load
	(according to IEC 947-5-1)
Overvoltage category:	III (according to IEC 60664-1)
Rated surge voltage:	4kV

### 7. Measuring circuit

Input:	terminals T1-T2
Initial resistance:	<1.5kΩ
Response value (relay in off-position):	≥3.6kΩ
Release value (relay in on-position):	≤1.8kΩ
Disconnection (short circuit thermistor):	<20Ω
Measuring voltage T1-T2:	≤2.5V DC at R ≤4.0kΩ
	(acc. to DINVDE 0660 part 302)
Overvoltage category:	III (according to IEC 60664-1)
Rated surge voltage:	4kV

### 8. Control contact R

Function:	external reset key
Loadable:	No
Line length R-T2:	max. 10m (twisted pair)
Control pulse length:	-
Reset:	potential free normally open contact, terminals R-T2

### 9. Accuracy

Base accuracy:	±10% (of maximum scale value)
Frequency response:	-
Adjustment accuracy:	-
Repetition accuracy:	≤1%
Voltage influence:	≤2.3%
Temperature influence:	≤0.1% / °C

### 10. Ambient conditions

Ambient temperature:	-25 to +55°C (according to IEC 68-1)
	-25 to +40°C (according to UL 508)
Storage temperature:	-25 to +70°C
Transport temperature:	-25 to +70°C
Relative humidity:	15% to 85%
	(according to IEC 721-3-3 class 3K3)
Pollution degree:	3 (according to IEC 60664-1)
Vibration resistance:	10 to 55Hz 0.35mm
	(according to IEC 68-2-6)
Shock resistance:	15g 11ms (according to IEC 68-2-27)

## Functions

### No additional function (OFF)

If the supply voltage U is applied (green LED illuminated) and the cumulative resistance of the PTC-circuit is less than 3.6kΩ (standard temperature of the motor), the output relays switch into on-position. Pressing the test/reset key under this conditions forces the output relays to switch into off-position. They remain in this state as long as the test/reset key is pressed and thus the switching function can be checked in case of fault. The test function is not effective using an external reset key.

When the cumulative resistance of the PTC-circuit exceeds 3.6kΩ (at least one of the PTCs has reached the cut-off temperature), the output relays switch into off-position (red LED illuminated). The output relays again switch into on-position (red LED not illuminated), if the cumulative resistance drops below 1.8kΩ by cooling down of the PTC and either a reset key (internal or external) was pressed or the supply voltage was disconnected and re-applied.

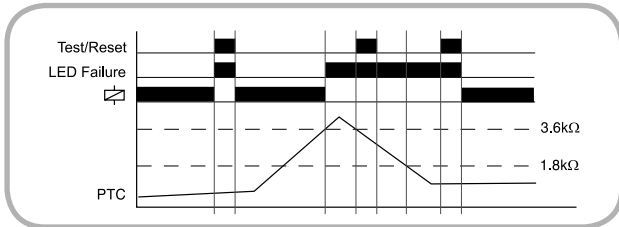
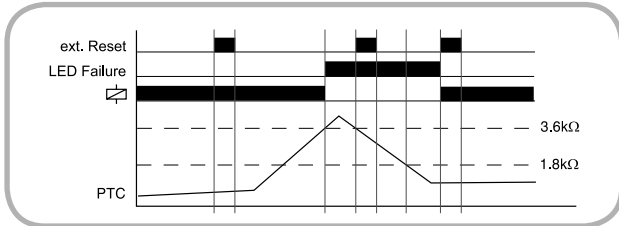

### Zero voltage latch (N)

If the supply voltage is interrupted and the additional function "Zero voltage latch" (+N or +N+K) is activated, the actual status of the output relays is stored and they switch into off-position if necessary. If the supply voltage is re-applied the status is restored. If this function is activated a fault can only be cleared by pressing the internal or external reset key.

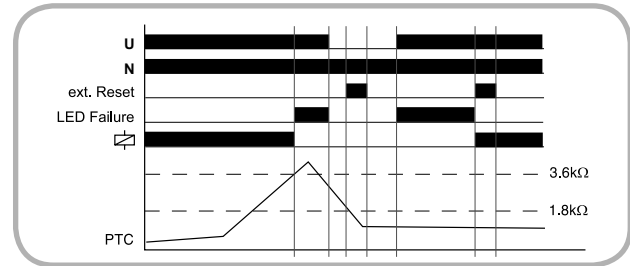

### Short circuit monitoring (K)

In case of a line brake or a short circuit of the probe line (cumulative resistance less than 20Ω) the output relays switch into off-position (red LED illuminated) if the additional function "Short circuit monitoring" (+K or +K+N) is activated.

Under these conditions however the output relays do not change their state, neither by pressing a reset key nor by disconnecting and re-applying the supply voltage.

## Connections

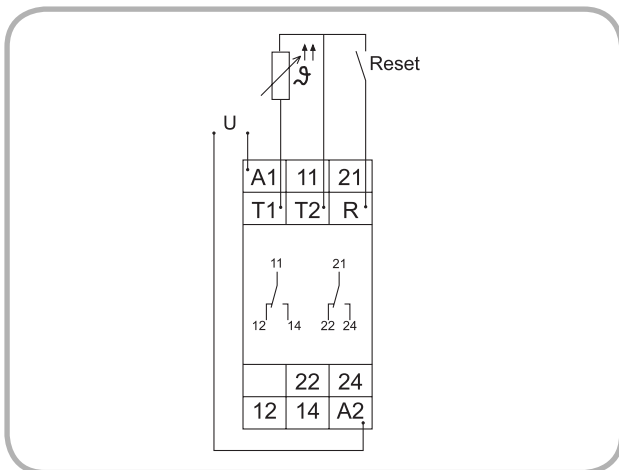

## Dimensions

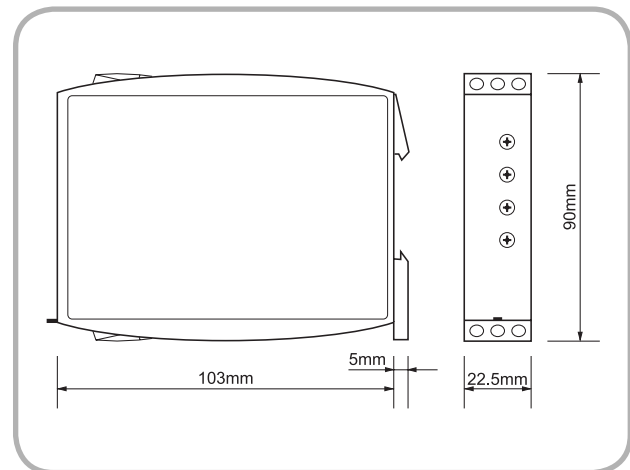

Subject to alterations and errors