

- ▶ 3-phase current monitoring
- ▶ Multifunction
- ▶ Fault latch
- ▶ Zoom voltage 24 to 240V AC/DC
- ▶ 2 change over contacts
- ▶ Width 22.5mm
- ▶ Industrial design



Technical data

1. Functions

3-phase current monitoring with adjustable thresholds, timing for start-up suppression and tripping delay separately adjustable and the following functions (selectable by means of rotary switch)

OVER	Overcurrent monitoring
OVER+LATCH	Overcurrent monitoring with fault latch
UNDER	Undercurrent monitoring
UNDER+LATCH	Undercurrent monitoring with fault latch
WIN	Monitoring the window between Min and Max
WIN+LATCH	Monitoring the window between Min and Max with fault latch

2. Time ranges

	Adjustment range	
Start-up suppression time:	0s	10s
Tripping delay:	0.1s	10s

3. Indicators

Green LED ON:	indication of supply voltage
Green LED flashes:	indication of start-up suppression time
Red LED ON/OFF:	indication of failure of the corresponding threshold
Red LED flashes:	indication of tripping delay of the corresponding threshold
Yellow LED ON/OFF:	indication of relay output

4. Mechanical design

Self-extinguishing plastic housing, IP rating IP40
 Mounted on DIN-Rail TS 35 according to EN 50022
 Mounting position: any
 Shockproof terminal connection according to VBG 4 (PZ1 required), IP rating IP20
 Tightening torque: max. 1Nm
 Terminal capacity:
 1 x 0.5 to 2.5mm² with/without multicore cable end
 1 x 4mm² without multicore cable end
 2 x 0.5 to 1.5mm² with/without multicore cable end
 2 x 2.5mm² flexible without multicore cable end

5. Input circuit

Supply voltage:
 24 to 240V AC/DC terminals A1-A2 (galvanically separated)
 Tolerance:
 24 to 240V AC/DC -20% to +25%
 24 to 240V AC/DC -15% to +10%
 Rated frequency:
 48 to 400Hz 24 to 240V AC
 16 to 48 Hz 48 to 240V AC
 Rated consumption: 2VA (1.5W)
 Duration of operation: 100%
 Reset time: 100ms
 Residual ripple for DC: -
 Drop-out voltage: >30% of the supply voltage

Overvoltage category: III (according to IEC 60664-1)
 Rated surge voltage: 4kV

6. Output circuit

2 potential free change over contacts
 Rated voltage: 250V AC
 Switching capacity (distance <5mm):
 750VA (3A / 250V AC)
 Switching capacity (distance >5mm):
 1250VA (5A / 250V AC)
 Fusing: 5A fast acting
 Mechanical life: 20 x 10⁶ operations
 Electrical life: 2 x 10⁵ operations at 1000VA resistive load
 max. 60/min at 100VA resistive load
 max. 6/min at 1000VA resistive load (according to IEC 947-5-1)
 Overvoltage category: III (according to IEC 60664-1)
 Rated surge voltage: 4kV

7. Measuring circuit

Measuring variable: AC Sinus (48 to 63Hz)
 Input: 5A AC, terminals K-I1, K-I2, K-I3 (distance >5mm)
 Overload capacity: 6A AC permanent
 Input resistance: 10mΩ
 Switching threshold:
 Max: 10% to 100% of I_N
 Min: 5% to 95% of I_N
 Overvoltage category: III (according to IEC 60664-1)
 Rated surge voltage: 4kV

8. Accuracy

Base accuracy: ±5% (of maximum scale value)
 Frequency response: -
 Adjustment accuracy: ≤5% (of maximum scale value)
 Repetition accuracy: ≤2%
 Voltage influence: -
 Temperature influence: ≤0.1% / °C

9. Ambient conditions

Ambient temperature: -25 to +55°C (according to IEC 68-1)
 -25 to +40°C (according to UL 508)
 Storage temperature: -25 to +70°C
 Transport temperature: -25 to +70°C
 Relative humidity: 15% to 85% (according to IEC 721-3-3 class 3K3)
 Pollution degree: 3 (according to IEC 60664-1)
 Vibration resistance: 10 to 55Hz 0.35mm (according to IEC 68-2-6)
 Shock resistance: 15g 11ms (according to IEC 68-2-27)

Functions

For all the functions the LEDs MIN and MAX are flashing alternating, when the minimum value for the measured current was chosen to be greater than the maximum value.

If a failure already exists when the device is activated, the output relays remain in off-position and the LED for the corresponding threshold is illuminated.

Overcurrent monitoring (OVER, OVER+LATCH)

When the measured current of one of the phases exceeds the value adjusted at the MAX-regulator, the set interval of the tripping delay (DELAY) begins (red LED MAX flashes). After the interval has expired (red LED MAX illuminated), the output relays switch into off-position (yellow LED not illuminated). The output relays again switch into on-position (yellow LED illuminated), when the measured current of all the phases falls below the value adjusted at the MIN-regulator (red LED MAX not illuminated).

If the fault latch is activated (OVER+LATCH) and the measured current of one of the phases remains above the MAX-value longer than the set interval of the tripping delay, the output relays remain in the off-position even if the measured current of all the phases falls below the value adjusted at the MIN-regulator. After resetting the failure (interrupting and re-applying the supply voltage), the output relays switch into on-position and a new measuring cycle begins with the set interval of the start-up suppression (START).

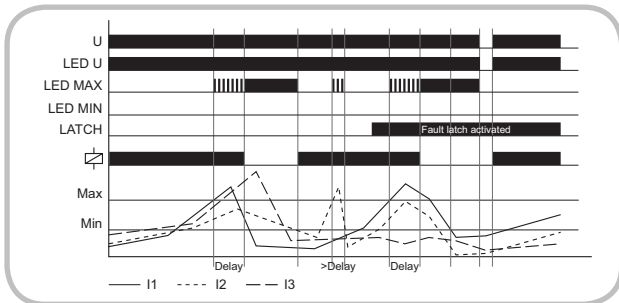

Undercurrent monitoring (UNDER, UNDER+LATCH)

When the measured current of one of the phases falls below the value adjusted at the MIN-regulator, the set interval of the tripping delay (DELAY) begins (red LED MIN flashes). After the interval has expired (red LED MIN illuminated), the output relays switch into off-position (yellow LED not illuminated). The output relays again switch into on-position (yellow LED illuminated), when the measured current of all the phases exceeds the value adjusted at the MAX-regulator.

If the fault latch is activated (UNDER+LATCH) and the measured current of one of the phases remains below the MIN-value longer than the set interval of the tripping delay, the output relays remain in the off-position even if the measured current of all the phases exceeds the value adjusted at the MAX-regulator. After resetting the failure (interrupting and re-applying the supply voltage), the output relays switch into on-position and a new measuring cycle begins with the set interval of the start-up suppression (START).

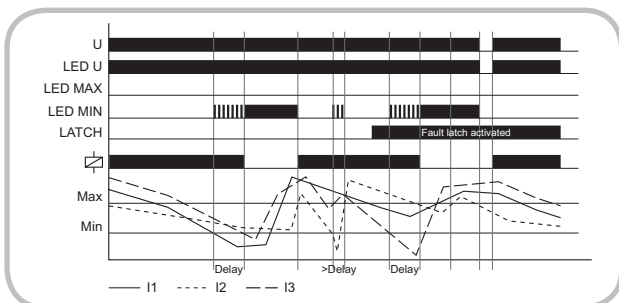

Window function (WIN, WIN+LATCH)

The output relays switch into on-position (yellow LED illuminated) when the measured current of all the phases exceeds the value adjusted at the MIN-regulator. When the measured current of one of the phases exceeds the value adjusted at the MAX-regulator, the set interval of the tripping delay (DELAY) begins (red LED MAX flashes). After the interval has expired (red LED MAX illuminated), the output relays switch into off-position (yellow LED not illuminated). The output relays again switch into on-position (yellow LED illuminated) when the measured current of all the phases falls below the value adjusted at the MAX-regulator (red LED MAX not illuminated). When the measured current of one of the phases falls below the value adjusted at the MIN-regulator, the set interval of the tripping delay (DELAY) begins again (red LED MIN flashes). After the interval has expired (red LED MIN illuminated), the output relays switch into off-position (yellow LED not illuminated).

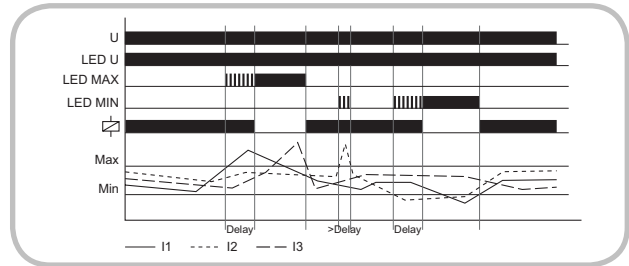

If the fault latch is activated (WIN+LATCH) and the measured current of one of the phases remains below the MIN-value longer than the set interval of the tripping delay, the output relays remain in the off-position even if the measured current of all the phases exceeds the value adjusted at the MIN-regulator. If the measured current of one of the phases remains above the MAX-value longer than the set interval of the tripping delay, the output relays remain in the off-position even if the measured current of all the phases falls below the value adjusted at the MAX-regulator. After resetting the failure (interrupting and re-applying the supply voltage), the output relays switch into on-position and a new measuring cycle begins with the set interval of the start-up suppression (START).

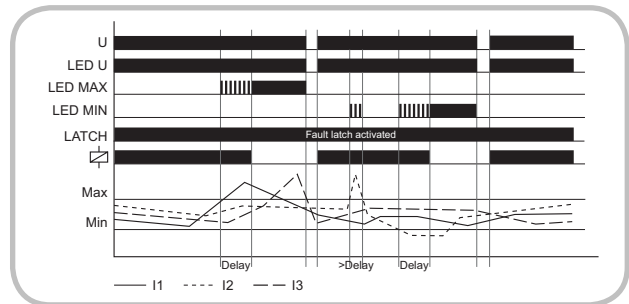

Connections

► G2JM5AL20, supply voltage 230V AC and current transformer

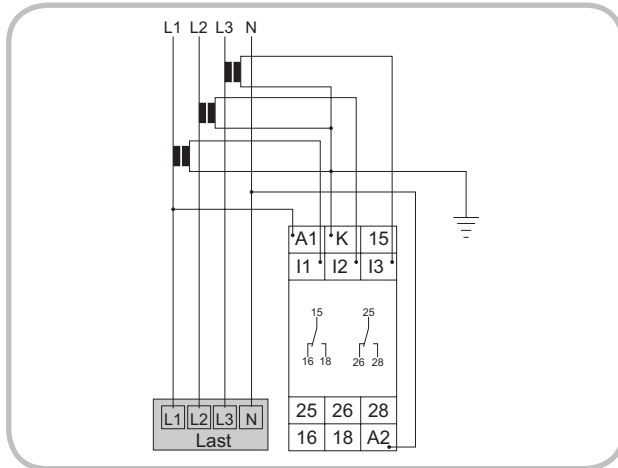

► G2JM5AL20, supply voltage 24-240V AC/DC without fault latch

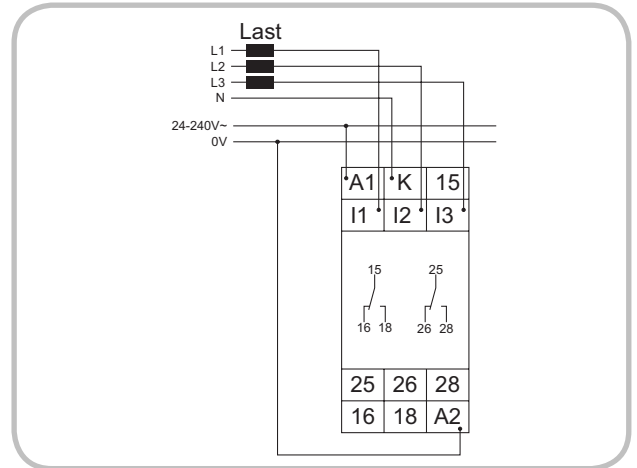

► G2JM5AL20, supply voltage 230V AC and fault latch

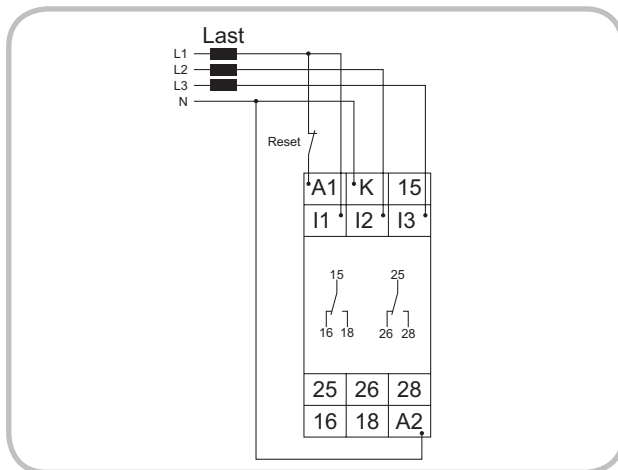

Subject to alternations and errors

Dimensions

