

Proximity switch with speed monitoring function in all-current technology in M 30 plastic casing.

For monitoring the operating frequency for control of slip, belt rupture, breakage or overload of conveyor belts, worm drives, mixture plants, pumps etc.

The comfortable TEACH-IN function allows programming of speed and start-up time. For adjustment the rated value can change in approx. 5% steps by pressing of the (+) and (-) push buttons

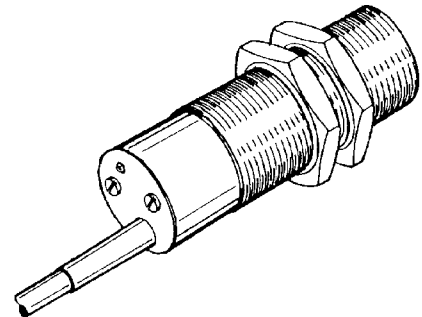

Technical Data

Type	IDL 010.05 G
Art.-No.	2474D
Monitoring frequency prog.	1...3000 puls./min.
Rated operating distance (S _n)	10 mm
Output	normally open Opened if the number of pulses is not reached
Target steel St37, 1 mm thick	30 x 30 mm
Location at metal	flush
Supply voltage (U _B)	20 - 260 V AC/DC
Power frequency	40 - 440 Hz
Load current max.	10 - 400 mA
Short- time load current	0,8 A / 100 ms 2 A / 10 ms
Short circuit protection	yes
Residual current (I _r)	2,5 mA / 260 V AC
Voltage drop (U _d)	10,5 V
Start-up time prog.	0 - 120 s
Switching hysteresis (H)	3 - 15 %
Switching hysteresis speed controller	10 %
Ambient temperature	-25 ... +70 °C
Protection class	IP 67
Connection	2 m cable
Function display	LED
Housing material	plastic PBT

When the supply voltage is applied the output closes for 9 s. Thereafter the sensor evaluates the actual operating frequency. If the rated value set is not reached, the output is blocked.

Diagram of Connections

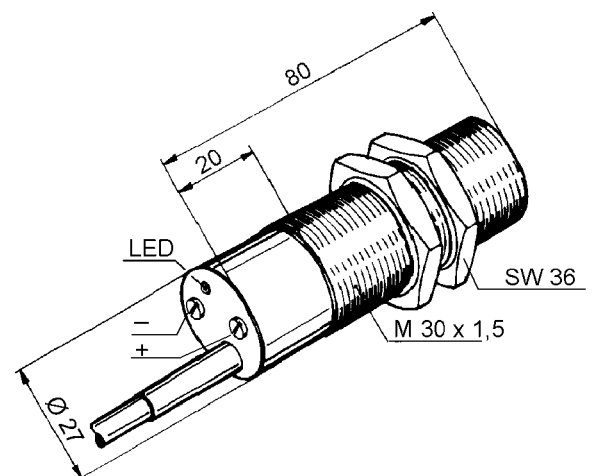
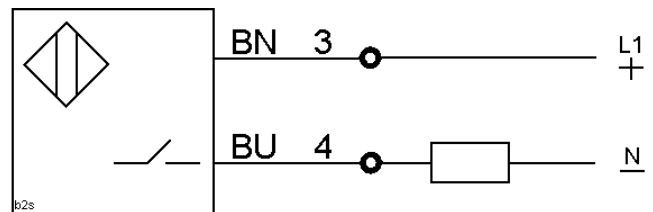

Proximity switch with speed monitoring function in all-current technology in M 30 plastic casing.

For monitoring the operating frequency for control of slip, belt rupture, breakage or overload of conveyor belts, worm drives, mixture plants, pumps etc.

The comfortable TEACH-IN function allows programming of speed and start-up time.

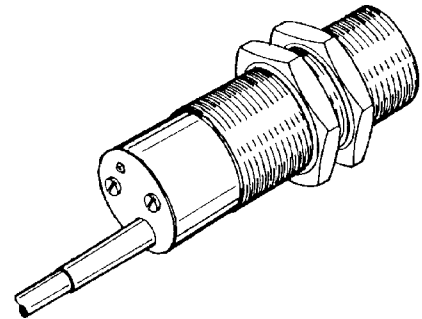

Technical Data

Type	IDL 015.05 G
Art.-No.	2474A
Monitoring frequency prog.	1...3000 puls./min.
Rated operating distance (Sn)	15 mm
Output	normally open Opened if the number of pulses is not reached
Target steel St37, 1 mm thick	45 x 45 mm
Location at metal	non flush
Supply voltage (UB)	20 - 260 V AC/DC
Power frequency	40 - 440 Hz
Ripple voltage	max. 15 % (DC)
Load current max.	10 - 400 mA
Short- time load current	0,8 A / 100 ms 2 A / 10 ms
Short circuit protection	yes
Residual current (Ir)	3,5 mA / 260 V AC
Voltage drop (Ud)	10,5 V
Start-up time prog.	0 – 120 s
Switching hysteresis (H)	3 - 15 %
Switching hysteresis speed controller	10 %
Ambient temperature	-25 ... +70 °C
Protection class	IP 67
Connection	2 m cable
Function display	LED
Housing material	plastic PBT

Diagram of Connections

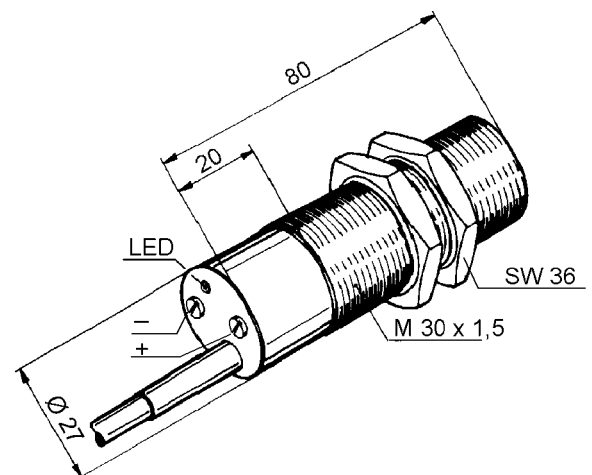
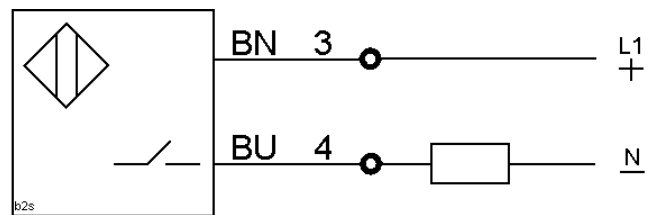

When the supply voltage is applied the output closes for 9 s. Thereafter the sensor evaluates the actual operating frequency. If the rated value set is not reached, the output is blocked.

For further setting information see 006D.