

# Rotary Measuring Technology

## Absolute hollow shaft encoder, Singleturn, CANopen

### Sendix Absolute, Singleturn Type 5878, CANopen

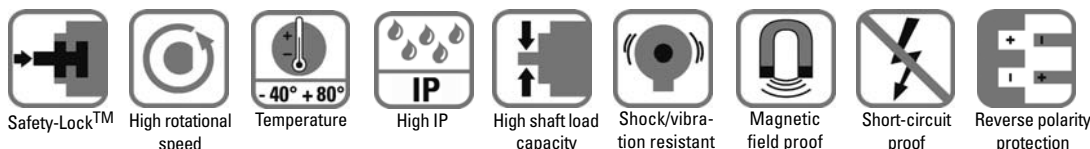

#### Reliable

- **Increased resistance against vibrations and installation mistakes. Avoids machine stops and repair work**  
Sturdy "Safety-Lock™ Design" bearing structure
- **Few components and connection points increase the operational reliability**  
Kübler OptoASIC technology with highest integration density (Chip-on-Board)
- **Remains tight, even in roughest environments, ensures highest safety against field breakdowns**  
Resistant die cast housing and protection up to IP 67
- **Can be used in a wide temperature range without additional charge**  
wide temperature range (-40°C...+90°C)



#### Fast

- **Really synchronous position acquisition of several axes**  
Extended CAN Sync Mode with real-time position acquisition
- **Fast data availability while reducing the load on the bus and the control**  
Intelligent functions like the transmission of speed, acceleration or exiting a working area

#### Versatile

- **Latest field bus performance for the applications**  
CANopen, with the latest profiles
- **The suitable connection variant for every specific case**  
Bus terminal cover with M12 connector or cable connection or fixed connection with M12, M23 or D-Sub connector, also easy point-to-point connections
- **Direct mounting also on large diameter standard shafts**  
Blind hollow shaft up to 15 mm
- **Position, Speed, acceleration, working area - The user decides which information is to be available in real-time**  
Variable PDO mapping in the memory
- **Quick and error-free start-up, without setting any switches**  
Node address, baud rate and termination can be programmed via the bus
- **Ex also available as explosion proof Zones 2 and 22**

Rotary Measurement Technology  
Absolute Encoders

#### Mechanical characteristics:

Max. speed without shaft sealing (IP 65) up to 70 °C:	9 000 min <sup>-1</sup> , continuous 7 000 min <sup>-1</sup>
Max. speed without shaft sealing (IP 65) up to Tmax:	7 000 min <sup>-1</sup> , continuous 4 000 min <sup>-1</sup>
Max. speed with shaft sealing (IP 67) up to 70 °C:	8 000 min <sup>-1</sup> , continuous 6 000 min <sup>-1</sup>
Max. speed with shaft sealing (IP 67) up to Tmax:	6 000 min <sup>-1</sup> , continuous 3 000 min <sup>-1</sup>
Starting torque without shaft sealing (IP65):	< 0.01 Nm
Starting torque with shaft sealing (IP67):	< 0.05 Nm
Moment of inertia:	6.0 x 10 <sup>-6</sup> kgm <sup>2</sup>
Weight:	appr. 0.53 kg with bus terminal cover appr. 0.50 kg with fixed connection housing
Protection acc. to EN 60 529:	housing: IP 67, shaft: IP 65, opt. IP 67
Working temperature:	-40° C ... +80 °C <sup>1)</sup>
Materials:	Hollow shaft: stainless steel, Bracket: aluminum, Housing: die cast aluminum, Cable: PVC
Shock resistance acc. to DIN-IEC 68-2-27:	>2500 m/s <sup>2</sup> , 6 ms
Vibration resistance acc. to DIN-IEC 68-2-6:	>100 m/s <sup>2</sup> , 55 ... 2000 Hz

<sup>1)</sup> Cable versions: -30 °C ... + 75 °C



**SET key:**  
For a fast and comfortable start-up on site.

**Green, red and yellow LEDs:**  
Failure-free operation immediately visible on the bus.

# Rotary Measuring Technology

## Absolute hollow shaft encoder, Singleturn, CANopen

### Sendix Absolute, Singleturn Type 5878, CANopen

#### General electrical characteristics:

Supply voltage:	10 ... 30 V DC
Current consumption (w/o output load):	24 V DC, max. 60 mA
Reverse polarity protection at power supply (Ub):	Yes
Conforms to CE requirements acc. to EN 61000-6-1, EN 61000-6-4 and EN 61000-6-3	

#### Interface characteristics CANopen:

Singleturn resolution (max, scaleable):	1 ... 65536 (16 bits), default scale value is set to 8192 (13 bits)
Code:	Binary
<b>Interface:</b>	CAN High-Speed according ISO 11898, Basic- and Full-CAN CAN Specification 2.0 B

#### General information about CANopen

The CANopen encoders of the 5878 series support the latest CANopen communication profile according to DS 301 V4.02. In addition, device-specific profiles like the encoder profile DS 406 V3.1 are available.

The following operating modes may be selected: Polled Mode, Cyclic Mode, Sync Mode and a High Resolution Sync Protocol. Moreover, scale factors, preset values, limit switch values and many other additional parameters can be programmed via the CAN-Bus. When switching the device on, all parameters, which have been saved on an EEPROM to protect them against power failure, are loaded again.

The following output values may be combined in a freely variable way as PDO (PDO mapping): **position, speed, acceleration**, as well as the status of the working area.

#### CANopen Communication Profile V4.02

Among others, the following functionality is integrated:

- Class C2 functionality
- NMT Slave
- Heartbeat Protocol
- High Resolution Sync Protocol Identity Object
- Error Behaviour Object
- Variable PDO Mapping self-start programmable (Power on to operational), 3 Sending PDO's
- 1 receiving PDO for synchronous preset operation with minimal jitter
- Node address address, baud rate and CANbus
- Programmable termination

#### SET control button (zero or defined value, option)

Protected against accidental activation, can only be pushed in with the tip of a ball pen or similar.

#### Diagnostic LED (yellow)

LED on at:  
optical sensor path faulty (code error, LED error), low voltage and overtemperature

<b>Protocol:</b>	CANopen profile DS 406 V3.1 with manufacturer-specific add-on's
<b>Baud rate:</b>	10 ... 1000 kbits/s (set by DIP switches/software configurable)
<b>Node address:</b>	1 ... 127 (set by rotary switches / software configurable)
<b>Termination switchable:</b>	Set by DIP switches Software configurable

As a price-effective variant, encoders with a connector or a cable connection are available, for which the device address and baud rate are modified by means of software. The models with bus terminal cover and integrated T-shaped coupler allow a particularly easy installation: bus and power supply are connected very simply thanks to M12 connectors; the device address is set by means of two hexadecimal rotary switches. Furthermore, another DIP switch allows setting the baud rate and switching on a termination resistor. Three LED's located on the back indicate the operating or fault status of the CAN bus, as well as the status of an internal diagnostic.

#### CANopen Encoder Profile V3.1

The following parameters can be programmed:

- Event mode
- Units for speed selectable (Steps/Sec or RPM)
- Factor for speed calculation (e.g. measuring wheel periphery) Integration time for speed value of 1...32
- 2 work areas with 2 upper and lower limits and the corresponding output states
- Variable PDO mapping for position, speed, acceleration, work area status
- Extended failure management for position sensing with integrated temperature control
- User interface with visual display of bus and failure status - 3 LED's
- Optional - 32 CAM's programmable
- Customer-specific memory - 16 Bytes

All profiles stated here: **Key-features**

The object 6003h "Preset" is assigned to an integrated key, accessible from the outside "Watchdog-controlled" device

# Rotary Measuring Technology

## Absolute hollow shaft encoder, Singleturn, CANopen

### Sendix Absolute, Singleturn Type 5878, CANopen

With removable bus terminal cover

ø 58 mm, Bracket with long torque stop  
Bracket type 1 and 2 (Drawing with 2x M12 connector)

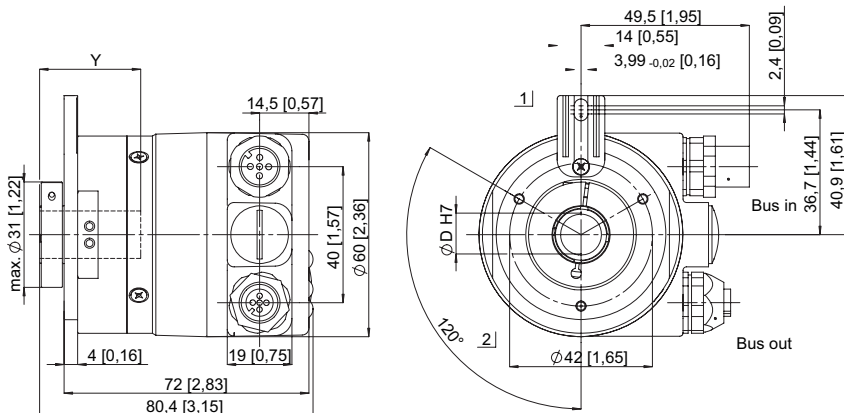

- 1 Torque stop slot, Recommendation: cyl. pin. acc. DIN 7 04
- 2 3 x M3, 5.5 [0.21] deep

ø 58 mm, Bracket with stator coupling  
Bracket type 5 and 6, pitch circle ø 63 mm (Drawing with cable version)

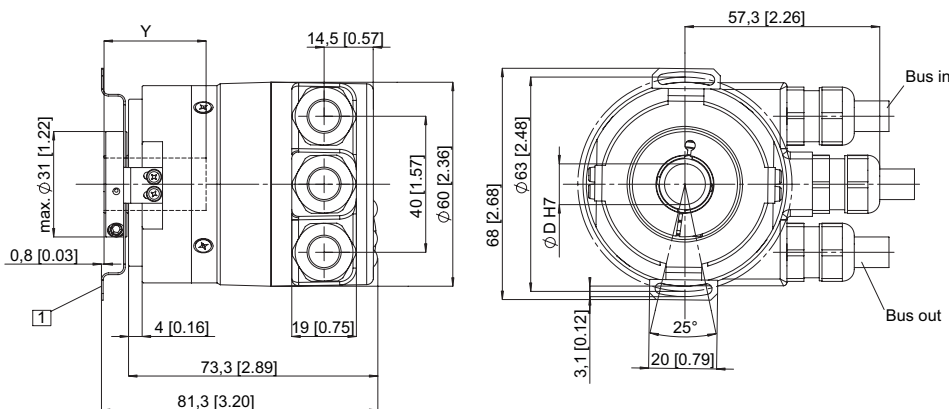

- 1 Fastening screw DIN 912 M3 x 8, washer included

ø 58 mm, Bracket with stator coupling  
Bracket type 3 and 4, pitch circle ø 65 mm (Drawing with 2x M12 connector)

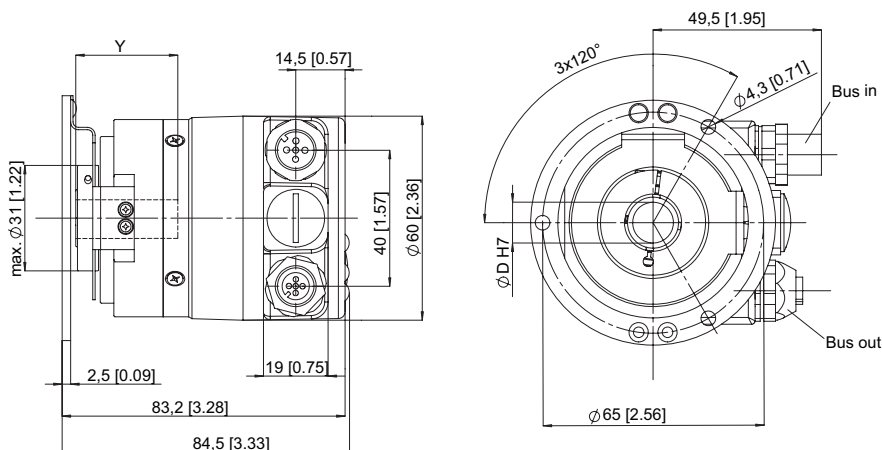

Y: Depth for blind hollow shaft: 30 mm

# Rotary Measuring Technology

## Absolute hollow shaft encoder, Singleturn, CANopen

### Sendix Absolute, Singleturn Type 5878, CANopen

**With fixed connection**

ø 58 mm, Stator coupling

Bracket type 1 and 2 (Drawing with 2 x M12 connector)

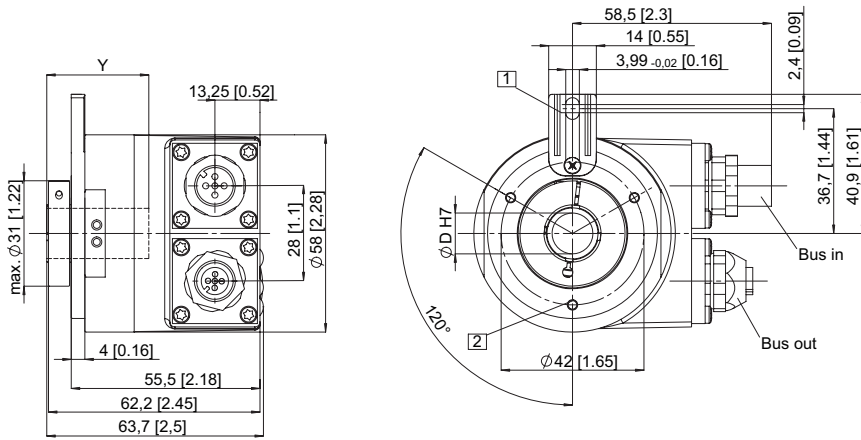

- 1 Torque stop slot,  
Recommendation: cyl. pin. acc. DIN 7 Ø4
- 2 3xM3, 5.5 [0.21] deep

ø 58 mm, Bracket with stator coupling

Bracket type 3 and 4, pitch circle ø 65 mm (Drawing with cable version)

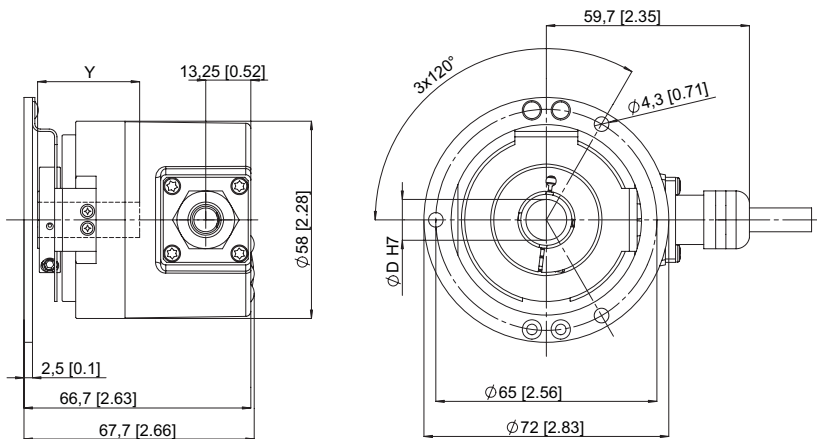

**Y: Depth for blind hollow shaft: 30 mm**

**Terminal assignment:**

Bus terminal cover with terminal box (type of connection 1)

Direction:	OUT					IN				
Signal:	CAN Ground	CAN_Low (-)	CAN_High (+)	0 Volt power supply	+UB power supply	0 V power supply	+UB power supply	CAN_Low (-)	CAN_High (+)	CAN Ground
Abbreviation:	CG	CL	CH	0 V	+V	0 V	+V	CL	CH	CG

# Rotary Measuring Technology

## Absolute hollow shaft encoder, Singleturn, CANopen

### Sendix Absolute, Singleturn Type 5878, CANopen

#### Terminal assignment:

Cable connection (type of connection A)

Direction:	IN				
Signal:	0 V power supply	+UB power supply	CAN_Low (-)	CAN_High (+)	CAN Ground
Abbreviation:	0 V	+V	CL	CH	CG
Cable colour:	BK	RD	BL	WH	GY

#### Terminal assignment:

Bus terminal cover with 2 x M12 connector (type of connection 2, F or J)

Direction:	OUT					IN				
Signal:	CAN Ground	CAN_Low (-)	CAN_High (+)	0 Volt power supply	+UB power supply	0 V power supply	+UB power supply	CAN_Low (-)	CAN_High (+)	CAN Ground
Abbreviation:	CG	CL	CH	0 V	+V	0 V	+V	CL	CH	CG
M23 PIN assignment	3	2	7	10	12	10	12	2	7	3
M12 PIN assignment	1	5	4	3	2	3	2	5	4	1

Bus in and out M23:

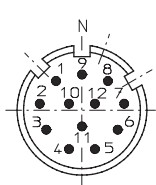

Bus out:

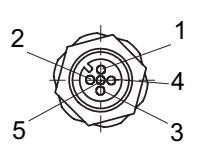

Bus in:

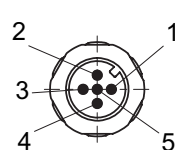

#### Terminal assignment:

M23 (type of connection I) or M12 (type of connection E) connector

Direction:	IN				
Signal:	0 V power supply	+UB power supply	CAN_Low (-)	CAN_High (+)	CAN Ground
Abbreviation:	0 V	+V	CL	CH	CG
M23 PIN assignment	10	12	2	7	3
M12 PIN assignment	3	2	5	4	1

Bus in M23:

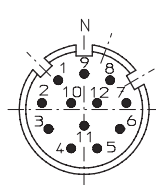

Bus in M12:

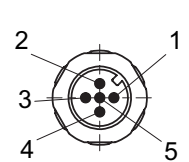

# Rotary Measuring Technology

## Absolute hollow shaft encoder, Singleturn, CANopen

### Sendix Absolute, Singleturn Type 5878, CANopen

Order code:

**8 . 5 8 7 8 . X X X X . X X 1 X**

- Type
- Bracket
  - 1 = Bracket with torque stop IP 65
  - 2 = Bracket with torque stop IP 67
  - 3 = Bracket with stator coupling pitch circle ø 65, IP 65
  - 4 = Bracket with stator coupling pitch circle ø 65, IP 67
  - 5 = Bracket with stator coupling pitch circle ø 63, IP 65**
  - 6 = Bracket with stator coupling pitch circle ø 63, IP 67
- Hollow shaft
  - 3 = ø 10 mm
  - 4 = ø 12 mm**
  - 5 = ø 14 mm
  - 6 = ø 15 mm
  - 8 = ø 9.52 mm [3/8"]
  - 9 = ø 12.7 mm [1/2"]
- Output circuit / Power supply
  - 2 = CANopen DS 301 V4.0**
  - 10 ... 30 V DC**

- Options (service)
  - 2 = No option
  - 3 = SET button**
- Field bus profile<sup>3)</sup>
  - 21 = CANopen Encoder-Profile DS 406 V3.1**
  - 22 = CANlift DS 417 V1.01
- Type of connection
  - 1 = With removable bus terminal cover, with radial screwed cable passage
  - 2 = Removable bus terminal cover with 2 x M12 connector**
  - A = Fixed connection without bus terminal cover, with radial cable (2 m PVC)
  - E = Fixed connection without bus terminal cover, with 1 x M12 radial connector
  - F = Fixed connection without bus terminal cover, with 2 x M12 radial connector
  - I = Fixed connection without bus terminal cover, with 1 x M23 radial connector
  - J = Fixed connection without bus terminal cover, with 2 x M23 radial connector

Ex-proof zone 2, 22 on request

*Preferred types are indicated in **bold***

<sup>3)</sup> CAN parameters can also be factory-preset

**Accessories:**

- Cables and connectors, also pre-assembled, can be found starting on Page 264
- Mounting attachments and couplings can be found starting on Page 301