

Rotary Measuring Technology

Absolute encoders, Multiturn, Ether CAT

Sendix absolut, Multiturn Type 5868 (Shaft) / 5888 (Hollow shaft), EtherCAT

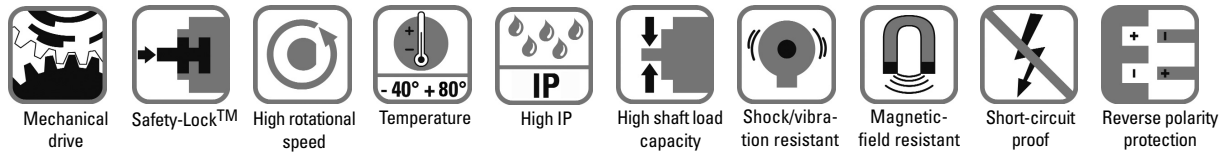

Reliable

- **Increased resistance against vibrations and installation errors.**
Eliminates machine downtime and repairs.
Sturdy bearing construction 'Safety-Lock™ Design'
- **Fewer components and connection points increase the operational reliability**
Kübler OptoASIC technology with very high integration density (Chip-on-Board)
- **Remains sealed, even in the roughest environments, ensures the highest safety against field breakdowns**
Resistant die-cast housing and protection up to IP 67
- **Can be used in a wide temperature range without additional charge**
wide temperature range (-40 °C ... +80 °C).



Fast

- **Time-synchronous position detection of several axes**
Distributed clock for real-time position detection
- **Fast data availability with reduced loading on the bus and controller**
Intelligent functions such as transmission of speed/velocity, acceleration or leaving a working area
- **Fast, simple, error-free connection**
Bus terminal cover with 3 x M12 connectors

Versatile

- **Up-to-the minute fieldbus performance in the CoE application**
CAN over Ethernet
- **Whether position, speed/velocity, acceleration or working area – the user decides, which information is available in real-time.**
PDO mapping in the memory
- **Fast, error-free start-up – no need to set switches**
All parameters can be programmed via the bus
- **Reliable installation in a wide diversity of mounting situations**
Extensive choice of proven mounting options
- **Numerous special functions**
Temperature monitoring, operating time, customer data (e.g. installation location)

Mechanical characteristics:

Max. speed without shaft seal (IP 65) up to 70 °C:	9 000 min ⁻¹ , continuous 7 000 min ⁻¹
Max. speed without shaft seal (IP 65) up to Tmax:	7 000 min ⁻¹ , continuous 4 000 min ⁻¹
Max. speed with shaft seal (IP 67) up to 70 °C:	8 000 min ⁻¹ , continuous 6 000 min ⁻¹
Max. speed with shaft seal (IP 67) up to Tmax:	6 000 min ⁻¹ , continuous 3 000 min ⁻¹
Starting torque without shaft seal (IP65):	< 0.01 Nm
Starting torque with shaft seal (IP67):	Shaft version: < 0.05 Nm Hollow shaft version: <0.03 Nm
Moment of inertia:	Shaft version: 3.0 x10 ⁻⁶ kgm ² Hollow shaft version: 7.5 x10 ⁻⁶ kgm ²
Radial load capacity of shaft:	80 N
Axial load capacity of shaft:	40 N
Weight:	approx. 0.54 kg
Protection acc. to EN 60 529:	housing: IP 67, shaft: IP 65, opt. IP 67
EX approval for hazardous areas:	optional zone 2 and 22
Working temperature:	-40 °C ... +80 °C
Materials:	Shaft: stainless steel, Flange: aluminium, Housing: die cast zinc
Shock resistance acc. to DIN-IEC 68-2-27:	>2500 m/s ² , 6 ms
Vibration resistance acc. to DIN-IEC 68-2-6:	>100 m/s ² , 55 ... 2000 Hz



- Absolutely safe operation even in strong magnetic fields
- Over 40 years of experience in the field of precision mechanics
- Special gears with specific toothings

Sendix absolut, Multiturn Type 5868 (Shaft) / 5888 (Hollow shaft), EtherCAT

General electrical characteristics:

Supply voltage:	10 ... 30 V DC
Current consumption (w/o output load):	24 V DC, max. 90 mA
Reverse polarity protection at power supply (Ub):	Yes
Conforms to CE requirements acc. to EN 61000-6-1, EN 61000-6-4 and EN 61000-6-3	
UL certified	File 224618
RoHS compliant acc. to EU guideline 2002/95/EG	

Device characteristics:

Singleturn resolution	1 ... 65535 (16 bit), (scaleable: 1 ... 65535)
Default value:	8192 (13 bit)
Total resolution:	scaleable from 1 to 268435456 (28 Bit) 12 Bit Multiturn
Code:	EtherNet Frame binary
Protocol:	EtherNet/EtherCAT

General information about CoE (CAN over EtherCAT)

The EtherCAT encoders of the 58X8 series support the CANopen communication profile according to DS 301. In addition device-specific profiles like the encoder profile DS 406 are available. Scaling, preset values, limit switch values and many other parameters can be programmed via the EtherCAT bus. When switching the device on, all parameters are loaded from an EEPROM, where they were saved to protect them against power-failure. As output values, position, speed, acceleration and temperature as well as the working area state can be combined as PDO (PDO Mapping).

Diagnostic LED (Red)

LED is ON with the following fault conditions:
Sensor error (internal code or LED error), low voltage, over-temperature

Run LED (Green)

LED is ON with the following conditions:
Init-, Preop-, Safeop and Op-State

2 x Link LED (Yellow)

LED is ON with the following conditions (Port A and B)
Link detected

Modes

Freerun, Distributed Clock (cycle time for Sync 0 pulse min. 125 µs or 62.5 µs with restrictions), Sync-Mode

CANopen Encoder Profile CoE (CAN over EtherCAT)

The following parameters are programmable:

- Units for speed selectable (Steps/Sec or RPM)
- Factor for speed calculation (e.g. circumference of measuring wheel)
- Integration time for the speed value from 1 ... 32
- 2 working area with 2 upper and lower limits and the corresponding output states
- PDO mapping of position, speed/velocity, acceleration and working area
- Extended error management for position sensing with integrated temperature control
- User interface with visual display of bus and fault status – 4 LEDs
- Alarm and warning messages

Terminal assignment bus:

(Type of connection 2, D-coded):

Direction:	Port A				Port B			
Signal:	Transmit data+	Receive data+	Transmit data-	Receive data-	Transmit data+	Receive data+	Transmit data-	Receive data-
Abbreviation:	TxD+	RxD+	TxD-	RxD-	TxD+	RxD+	TxD-	RxD-
M12 PIN-connection:	1	2	3	4	1	2	3	4

Port A and B

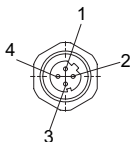

Terminal assignment power supply:

M12 connector

Signal:	+UB Power supply	n.c.	0 V	n.c.
Abbreviation:	+UB	-	0 V	-
M12 PIN-connection	1	2	3	4

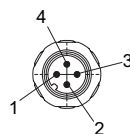

Bus connection

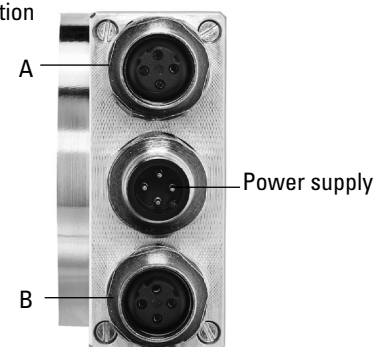

Rotary Measuring Technology

Absolute encoders, Multiturn, Ether CAT

Sendix absolut, Multiturn Type 5868 (Shaft) / 5888 (Hollow shaft), EtherCAT

Dimensions shaft version:
With removable bus terminal cover:

ø 58 mm, Synchro flange
Flange type 2 und 4

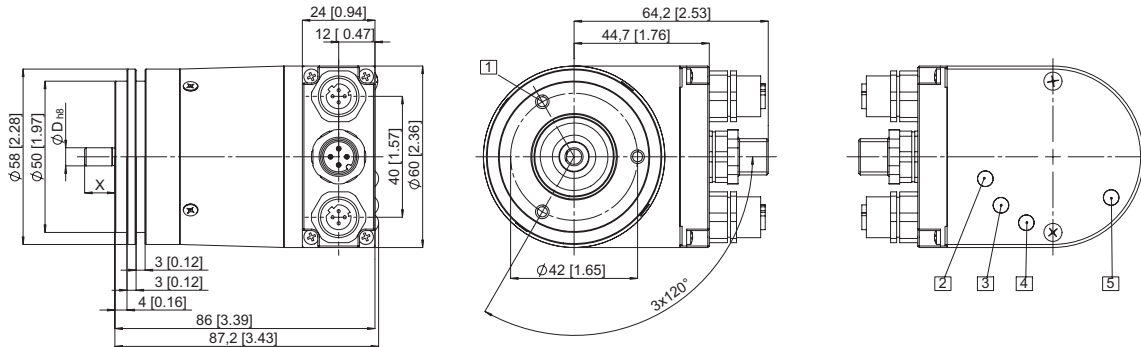

- 1 3xM4, 6,0 [0.24] deep
- 2 Link a, yellow LED
- 3 Link b, yellow LED
- 4 Run, green LED
- 5 Err, red LED

ø 58 mm, Clamping flange
Flange type 1 and 3

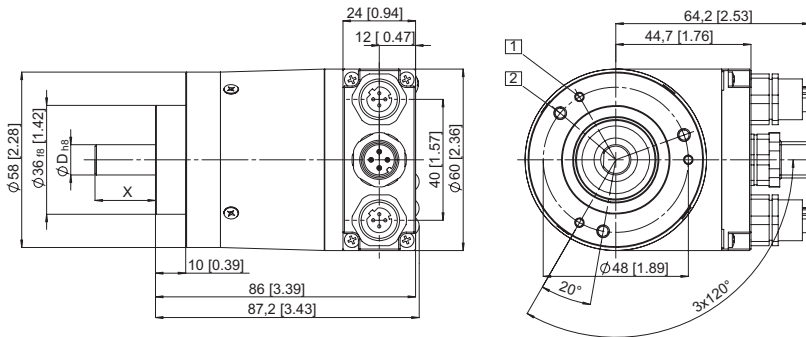

- 1 3xM3, 6,0 [0.24] deep
- 2 3xM4, 8,0 [0.31] deep

63,5 mm, Square flange □
Flange type 5 und 7

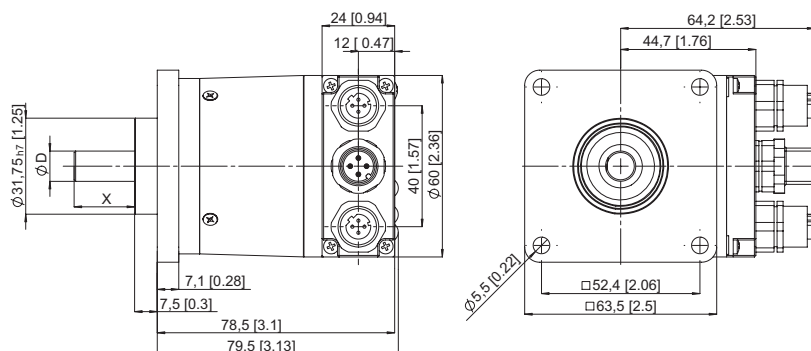

Sendix absolut, Multiturn Type 5868 (Shaft) / 5888 (Hollow shaft), EtherCAT

Order code shaft version:

8 . 5 8 6 8 . X X X X . X X 1 2

- Type
- Flange
- 1 = Clamping flange ø 58 IP 65**
 - 2 = Synchro flange ø 58 mm, IP65**
 - 3 = Clamping flange ø 58 mm, IP 67
 - 4 = Synchro flange ø 58 mm, IP67
 - 5 = Square flange 2.5" / 63.5 mm, IP 65
 - 7 = Square flange 2.5" / 63.5 mm, IP 67
- Shaft
- 1 = Shaft 6 mm x 10 mm (ø x L)¹⁾**
 - 2 = Shaft 10 mm x 20 mm (ø x L)²⁾**
 - 3 = Shaft 1/4" x 7/8" (ø x L)
 - 4 = Shaft 3/8" x 7/8" (ø x L)

Field bus profile
B1 = EtherCAT with CoE
 (CAN over EtherNet)

Type of connection
2 = Removable bus terminal cover with 3 x M12 connector

Accessories:

- Cables and connectors, also pre-assembled, can be found in the chapter Counting Technology
- Mounting attachments and couplings can be found in the Chapter Accessories

Output circuit / Power supply
B = EtherCAT

¹⁾ Preferred type with flange type 2
²⁾ Preferred type with flange type 1

Preferred types are indicated in bold

Dimensions hollow shaft version (blind hollow shaft):

With removable bus terminal cover
 ø 58 mm, Flange with torque stop
 Flange type 1 and 2

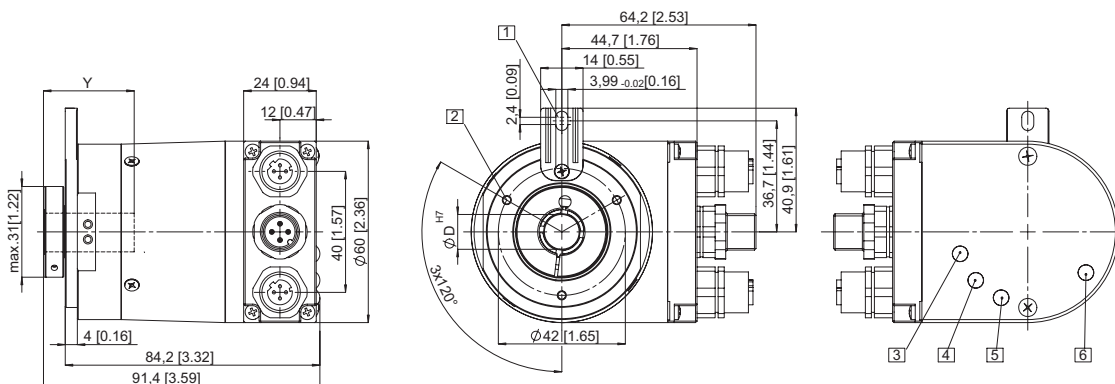

- 1** Torque stop slot
 Recommendation cyl. pin
 DIN 7, ø 4 mm
- 2** 3xM3, 5,5 [0.21] deep
- 3** Link a, yellow LED
- 4** Link b, yellow LED
- 5** Run, green LED
- 6** Err, red LED

Rotary Measuring Technology

Absolute encoders, Multiturn, Ether CAT

Sendix absolut, Multiturn Type 5868 (Shaft) / 5888 (Hollow shaft), EtherCAT

Dimensions hollow shaft version (blind hollow shaft):

With removable bus terminal cover

ø 58 mm, Flange with stator coupling
Flange type 5 and 6

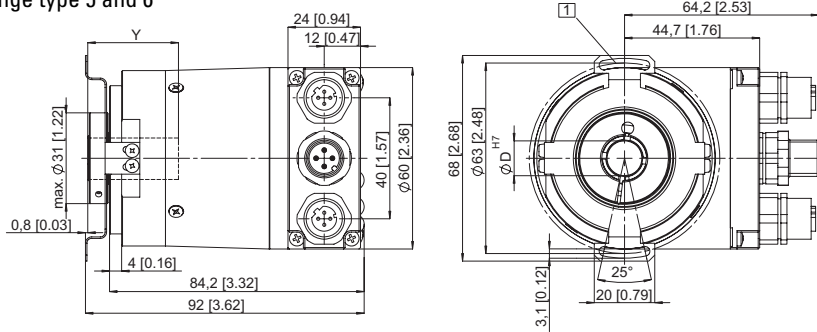

1 Fastening screw DIN 912 M3 x 8, washer included

ø 58 mm, Flange with stator coupling
Flange type 3 and 4

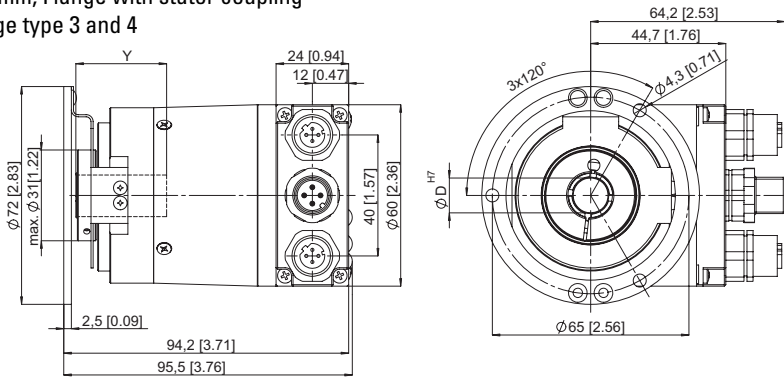

Y: Depth for blind hollow shaft: 30 mm

Order code hollow shaft version:

8 . 5 8 8 8 . X X X X . X X 1 2

- Type
- Flange
 - 1 = Flange with torque stop IP 65
 - 2 = Flange with torque stop IP 67
 - 3 = Flange with stator coupling pitch circle ø 65, IP 65
 - 4 = Flange with stator coupling pitch circle ø 65, IP 67
 - 5 = Flange with stator coupling pitch circle ø 63, IP 65**
 - 6 = Flange with stator coupling pitch circle ø 63, IP 67
- Hollow shaft
 - 3 = Blind hollow shaft ø 10 mm
 - 4 = Blind hollow shaft ø 12 mm**
 - 5 = Blind hollow shaft ø 14 mm
 - 6 = Blind hollow shaft ø 15 mm
 - 8 = Blind hollow shaft ø 9.52 mm [3/8"]
 - 9 = Blind hollow shaft ø 12.7 mm [1/2"]
- Output circuit / Power supply
 - B = EtherCAT**
 - Ex-proof zone 2, 22 on request

Field bus profile
B1 = EtherCAT with CoE
(CAN over EtherNet)

Type of connection
2 = Removable bus terminal cover with 3 x M12 connector

Accessories:
– Cables and connectors, also pre-assembled, can be found in the chapter Counting Technology
– Mounting attachments and couplings can be found in the Chapter Accessories

Preferred types are indicated in bold

Absolute Encoders