

Rotary Measuring Technology

Absolute shaft encoder, Multiturn, SSI/BiSS

Sendix Absolute, Multiturn Type 5863, SSI/BiSS



Mechanical drive



Safety-Lock™



High rotational speed

Temperature
-40° +90°

High IP



High shaft load capacity



Shock/vibration resistant



Magnetic field proof



Short-circuit proof



Reverse polarity protection



SIN/COS

Reliable

- **Increased resistance against vibrations and installation mistakes. Avoids machine stops and repair work**
Sturdy "Safety-Lock™ Design" bearing structure
- **Few components and connection points increase the operational reliability**
Kübler OptoASIC technology with highest integration density (Chip-on-Board)
- **Remains tight, even in roughest environments, ensures highest safety against field breakdowns**
Resistant die cast housing and protection up to IP 67
- **Can be used in a wide temperature range without additional charge**
wide temperature range (-40°C...+90°C)
- **Easy diagnostic in case of trouble**
Status indication by means of LED, sensor, voltage and temperature monitoring.



Fast

- **Can achieve particularly high accuracy in the applications**
Update rate of the whole position value above 100 kHz
- **Allows high productivity thanks to very short regulation cycles**
Clock rate with SSI up to 2 MHz, with BiSS up to 10 MHz
- **High-resolution feedback system achievable in real-time**
SinCos incremental outputs.

Versatile

- **The suitable connection variant for every specific case**
Cable, M23 connector or M12 connector
- **Open interfaces ensure flexibility and independence**
SSI or BiSS with Sine-Cosine-Option
- **Reliable mounting in the most various installation cases**
Comprehensive and proven mounting possibilities
- **Only the functionality really needed by the user is implemented**
Status LED and Set key available as options
- **Fast and comfortable start-up on site**
Set key or Preset by means of a control input.
- **also available as explosion proof Zones 2 and 22**

Mechanical characteristics:

Max. speed without shaft sealing (IP 65) up to 70 °C:	12 000 min ⁻¹ , continuous 10 000 min ⁻¹
Max. speed without shaft sealing (IP 65) up to T _{max} :	8 000 min ⁻¹ , continuous 5 000 min ⁻¹
Max. speed with shaft sealing (IP 67) up to 70 °C:	11 000 min ⁻¹ , continuous 9 000 min ⁻¹
Max. speed with shaft sealing (IP 67) up to T _{max} :	8 000 min ⁻¹ , continuous 5 000 min ⁻¹
Starting torque without shaft sealing (IP 65):	< 0.01 Nm
Starting torque with shaft sealing (IP 67):	< 0.05 Nm
Moment of inertia:	4.0 x 10 ⁻⁶ kgm ²
Radial load capacity of shaft:	80 N
Axial load capacity of shaft:	40 N
Weight:	appr. 0.45 kg
Protection acc. to EN 60 529:	housing: IP 67, shaft: IP 65, opt. IP 67
Working temperature:	-40° C ... +90° C ¹⁾
Materials:	Shaft: stainless steel, Bracket: aluminum, Housing: die cast zinc, Cable: PVC
Shock resistance acc. to DIN-IEC 68-2-27:	>2500 m/s ² , 6 ms
Vibration resistance acc. to DIN-IEC 68-2-6:	>100 m/s ² , 55 ... 2000 Hz

¹⁾ Cable versions: -30 °C ... + 75 °C



- Absolutely safe operation even in strong magnetic fields
- Over 40 years of experience in the field of precision mechanics
- Special gears with specific toothings

Sendix Absolute, Multiturn Type 5863, SSI/BISS

General electrical characteristics:

Supply voltage:	5 V DC \pm 5% or 10 ... 30 V DC
Current consumption (w/o output load):	5 V DC: max. 75 mA, 24 V DC: max. 25 mA
Reverse polarity protection at power supply (Ub):	Yes (only 10 ... 30 V DC)
Conforms to CE requirements acc. to EN 61000-6-1, EN 61000-6-4 and EN 61000-6-3	

General Interface characteristics:

Output driver:	RS 485 Transceiver type
Permissible load/channel:	max. \pm 20 mA
Signal level high:	typ. 3.8 V
Signal level low at $I_{load} = 20$ mA:	typ. 1.3 V
Short circuit proof outputs:	Yes ²⁾

Interface characteristics SSI:

Singleturn resolution:	10...14 bits and 17 bits ³⁾
Number of revolutions:	4096 (12 bits)
Code:	Binary or Gray
SSI clock rate:	\leq 14 bits: 50 kHz ... 2 MHz
Monoflop time:	\geq 15 μ s ³⁾

Note:
If clock starts cycling within monoflop time a second data transfer starts with the same data, useful for data verification. If clock starts cycling after monoflop time the data transfer starts with updated values. Max. update rate is depending on clock speed, data length and monoflop-time.

Time jitter (data request to position latch):	$<$ 1 μ s up to 14 bits, \leq 4 μ s at 15 ... 17 bits
Status and Parity bit:	optional on request

Interface characteristics BISS:

Singleturn resolution:	10...14 bits and 17 bits, customer programmable ³⁾
Number of revolutions:	4096 (12 bits)
Code:	Binary
Clock rate:	up to 10 MHz
Max. update rate:	$<$ 10 μ s, depending on clock speed and data length

Time jitter (data request to position latch): \leq 1 μ s

- Note:
- Bidirectional, programmable parameters are: resolution, code, direction, alarms and warnings
 - Multicycle data output, e.g. for temperature
 - CRC data verification

²⁾ Short circuit to 0V or to output, one channel at a time, supply voltage correctly applied ³⁾ Other options upon request

SET (zero or defined value) and DIRrection (CW/CCW) control inputs

Input characteristics:	High active
Receiver type:	Comparator
Signal level high:	min. 60 % of V+ (Supply voltage), max: V+
Signal level low:	max. 25% of V+ (Supply voltage)
Input current:	\leq 0.5 mA
Min. pulse duration (SET):	10 ms
Timeout after SET input:	14 ms
Reaction Time (DIR input):	1 ms

Status output

Output driver:	Open collector, internal pull up resistor 22 kOhm
Permissible load:	-20 mA
Signal level high:	+V
Signal level low:	$<$ 1 V
Active at:	Low
optical sensor path faulty (code error, LED error), low voltage and overtemperature	

Status LED (red, option)

LED on at:	optical sensor path faulty (code error, LED error), low voltage and overtemperature
------------	---

SET control button (zero or defined value, option)

Same functionality as SET control input, protected against accidental activation, can only be pushed in with the tip of a ball pen or similar.

Output Sine, Cosine, 2048 ppr (option)

-3dB frequency:	400 kHz
Signal level:	1 V _{pp} (\pm 20%)
Short circuit proof:	Yes ²⁾

Sendix Absolute, Multiturn Type 5863, SSI/BiSS

Synchro bracket

ø 58 mm, M12, M23 connector, cable versions
 Bracket type 2 and 4 (Drawing with M12 connector)

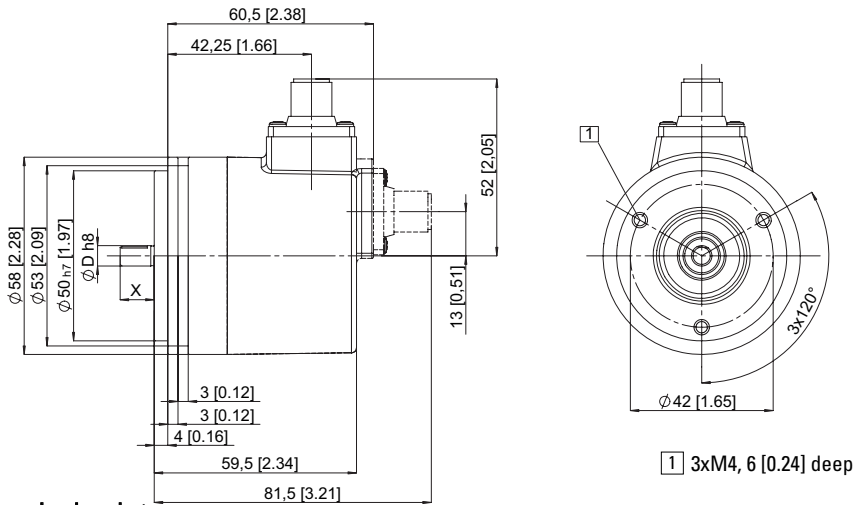

Clamping bracket

ø 58 mm, M12, M23 connector, cable versions
 Bracket type 1 and 3 (Drawing with M23 connector)

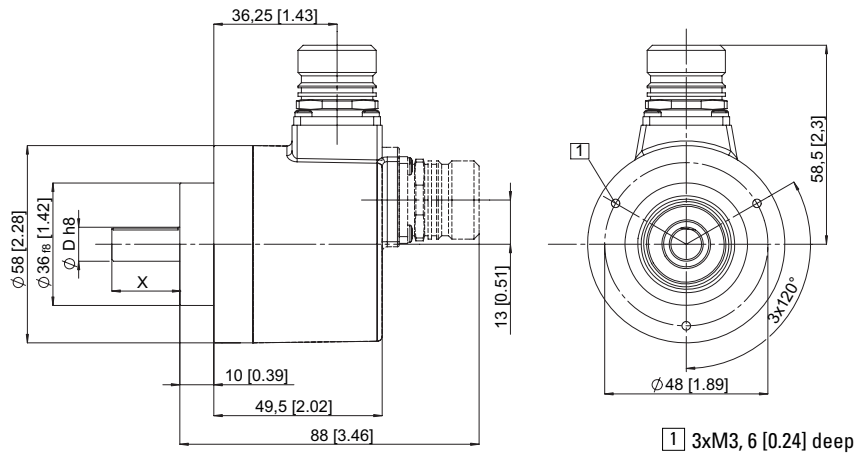

Square bracket

63.5 mm □, M12, M23 connector, cable versions
 Bracket type 5 and 7 (Drawing with cable version)

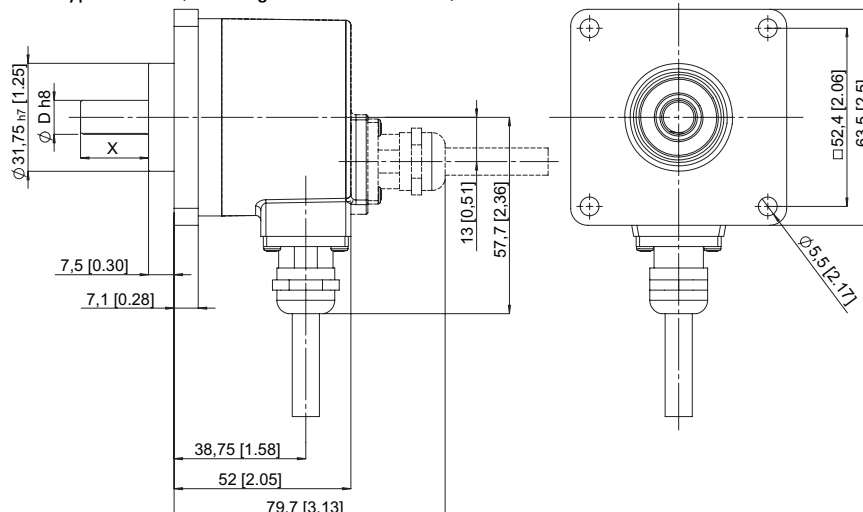

Rotary Measuring Technology

Absolute shaft encoder, Multiturn, SSI/BiSS

Sendix Absolute, Multiturn Type 5863, SSI/BiSS

Terminal assignment:

for output circuit 1 or 2 and type of connection 1, 2, 3 or 4 (2 control inputs, 1 status output)

Signal:	GND	+V	+C	-C	+D	-D	SET	DIR	Stat	N/C	N/C	N/C	PE
Cable colour:	WH	BN	GN	YE	GY	PK	BU	RD	BK	-	-	-	Shield
M23 PIN out:	1	2	3	4	5	6	7	8	9	10	11	12	PH

for output circuit 5 and type of connection 1, 2, 3 or 4 (2 control inputs, 1 status output, voltage sense outputs)

Signal:	GND	+V	+C	-C	+D	-D	SET	DIR	Stat	N/C	0 V Sens	+Ub Sens	PE
Cable colour:	WH	BN	GN	YE	GY	PK	BU	RD	BK	-	GY-PK	RD-BU	Shield
M23 PIN out:	1	2	3	4	5	6	7	8	9	10	11	12	PH

for output circuit 3 or 4 and type of connection 1, 2, 3 or 4 (2 control inputs, 1 status output, sine/cosine)

Signal:	GND	+V	+C	-C	+D	-D	SET	DIR	A	A inv	B	B inv	PE
Cable colour:	WH	BN	GN	YE	GY	PK	BU	RD	BK	VT	GY-PK	RD-BU	Shield
M23 PIN out:	1	2	3	4	5	6	7	8	9	10	11	12	PH

for output circuit 6 and type of connection 1, 2, 3 or 4 (2 control inputs, sine/cosine, voltage sense outputs)

Signal:	GND	+V	+C	-C	+D	-D	A	A inv	B	B inv	0V Sens	+Ub Sens	PE
Cable colour:	WH	BN	GN	YE	GY	PK	BU	RD	BK	VT	GY-PK	RD-BU	Shield
M23 PIN out:	1	2	3	4	5	6	7	8	9	10	11	12	PH

for output circuit 1 or 2 and type of connection 5 or 6 (2 control inputs)

Signal:	GND	+V	+C	-C	+D	-D	SET	DIR	Shield/PE
M12 PIN out:	1	2	3	4	5	6	7	8	PH

- +V: Encoder Power Supply +V DC
- GND: Encoder Power Supply Ground (0V)
- +C, -C: Clock signal
- +D, -D: Data signal
- SET: Set input. The current position becomes defined as position zero
- DIR: Direction input: If this input is active, output values are decreasing when shaft is turned clockwise.
- Stat: Status output
- PE: Protective earth
- PH: Plug housing (shield)
- A, Ainv: Sine output (incremental)
- B, Binv: Cosine output (incremental)

Rotary Measuring Technology

Absolute shaft encoder, Multiturn, SSI/BiSS

Sendix Absolute, Multiturn Type 5863, SSI/BiSS

Order code:

8 . 5 8 6 3 . X X X X . X X X X

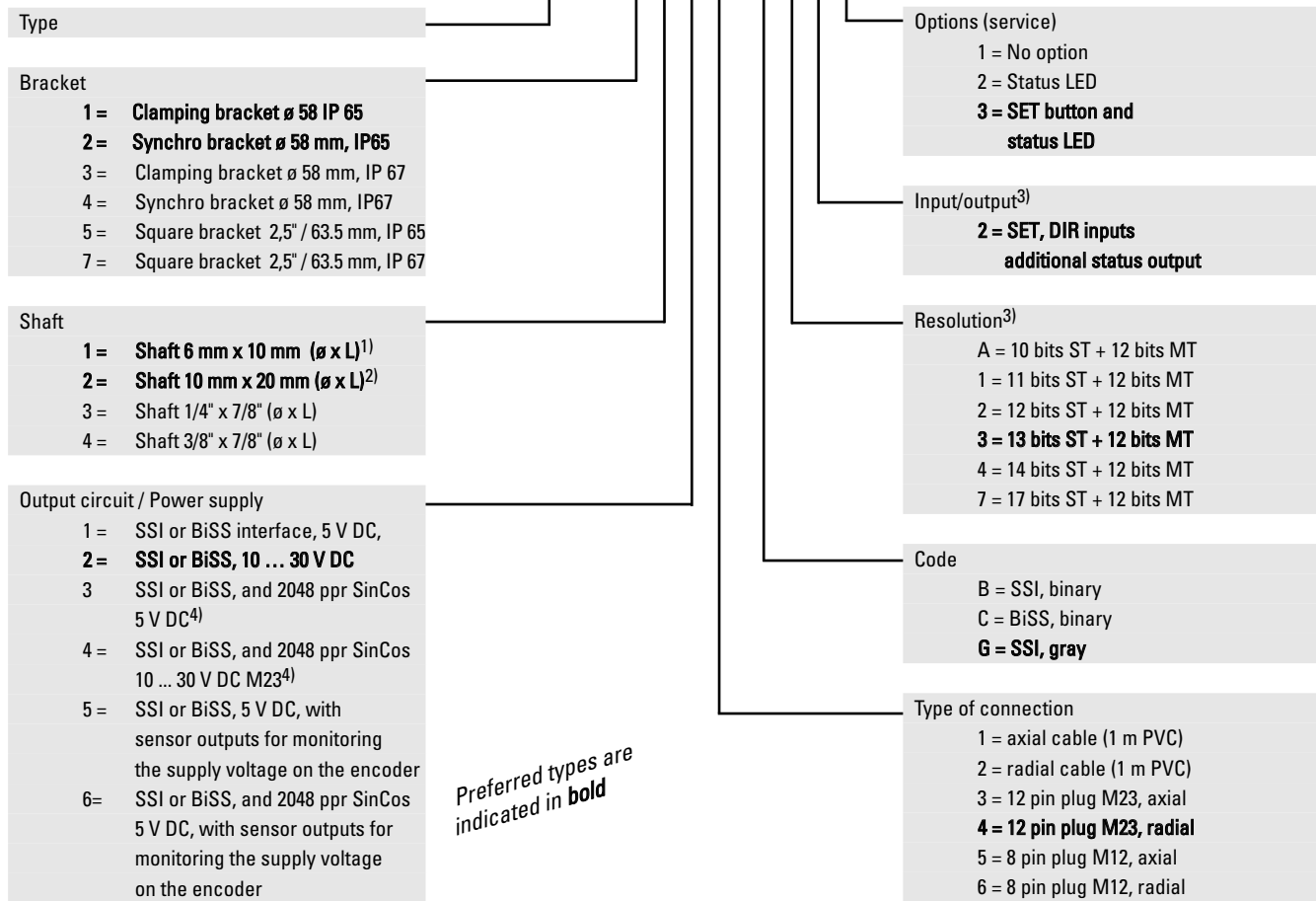

Preferred types are indicated in bold

Ex-proof zone 2, 22 on request

1) Preferred type with bracket type 2

2) Preferred type with bracket type 1

3) Resolution, preset value and counting direction factory-programmable

Accessories:

– Cables and connectors, also pre-assembled, can be found starting on Page 264

– Mounting attachments and couplings can be found starting on Page 301