

# Rotary Measuring Technology

## Magnetic measurement system

### Absolute Singleturn Encoder Type 3650

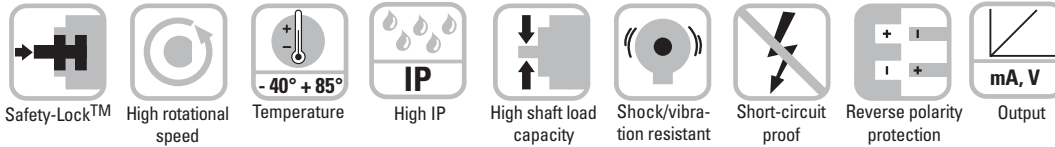

**Rugged**

- **Ensures long service life and reliability of the application, no wear**  
Non-contact measuring system
- **Stays sealed even when subjected to harsh everyday use. Offers security against failures in the field**  
Solid die-cast housing with up to IP 69K protection
- **Can be used for a wide temperature range without additional expense.**  
Wide temperature range (-40 °C ... +85 °C)
- **Increased ability to withstand vibration and installation errors. Eliminates machine downtime and repairs.**  
High shock resistance (> 500g) and vibration resistance (>30g)
- **Can be used in outdoor applications with large fluctuations in temperature.**  
Resistant against humidity and condensation.



**Compact**

- **Can be used where space is tight**  
Overall diameter of only 36 mm
- **Compact encoder can be used on large diameter shafts**  
Fixing holes on D26 mm

**Versatile**

- **Interface: 9-Bit SSI, 4 ... 20 mA, 0 ... 10 V**  
One size available for different applications
- **Measuring range: 45°; 90°; 180°; 360°:**  
Suitable measuring range available for different applications
- **Enables simple installation**  
Reference point can be identified via LED (green)
- **Easy diagnosis in case of fault condition**  
Error indication via LED (red)
- **Can be fixed on various diameters**  
Fixing holes on D 26mm and D 30mm

**Mechanical characteristics:**

Max. speed:	6000 min <sup>-1</sup>
Starting torque	< 0,06 Nm
Radial load capacity of shaft:	40 N
Axial load capacity of shaft:	20 N
Weight:	appr. 0,2 kg
Protection acc. to EN 60 529:	IP 67 (IP 69k on request)
Working temperature range:	-40 °C ... +85 °C
Materials:	Shaft: stainless steel, Flange: aluminium, Housing: die cast zinc, Cable: PUR
Shock resistance acc. to DIN-IEC 68-2-27:	5000 m/s <sup>2</sup> , 6 ms
Vibration resistance acc. to DIN-IEC 68-2-6:	300 m/s <sup>2</sup> , 10 ... 2000 Hz
Permanent shock resistance acc. to DIN-IEC 68-2-29	1000 m/s <sup>2</sup> , 2 ms
Vibration (broad-band random) to DIN-IEC 68-2-64	5 ... 2500 Hz, 100 m/s <sup>2</sup> - rms

### Absolute Singleturn Encoder Type 3650

#### Electrical characteristics SSI Interface:

<b>Sensor:</b>	
Supply voltage:	5 ... 30 V DC <sup>1)</sup>
Current consumption (w/o output load):	typ 22 mA, max. 41 mA
Reverse polarity protection at power supply (Ub):	Yes
Measuring range:	360°
Resolution/Code:	9 Bit/Binary
Linearity (25 °C)	<1.0 %
Repeat accuracy:	<0.2 %
Data refresh rate:	typ 100 µs
Status LED:	Green, reference point at 2,1°

<b>SSI interface</b>	
Clock speed:	100 kHz ... 1 MHz
Output driver:	RS 485
Monoflop time typ./max.:	16 µs/20 µs
Short circuit proof outputs:	Yes <sup>2)</sup>
Permissible load/channel	typ. 120 Ohm (corresponding RS 485)

- <sup>1)</sup> The supply voltage at the encoder input must not be less than 4.75 V (5 V - 5%)  
<sup>2)</sup> Short circuit to 0V or to output, only one channel at a time, supply voltage correctly applied

#### Terminal assignment:

<b>Sig.:</b>	0V	+Ub	0 V Sens	+Ub Sens	+T	-T	+D	-D
<b>Col.:</b>	WH	BN	BU	RD	GN	YE	GY	PK

#### Electrical characteristics current interface 4 ... 20 mA:

<b>Sensor:</b>	
Supply voltage:	18 ... 30 V DC
Current consumption (w/o output load):	typ 25 mA, max. 42 mA
Reverse polarity protection at power supply (Ub):	Yes
Measuring range:	45°, 90°, 180° or 360° (see also table „measuring range“)
Linearity (25 °C)	<1.0 % (360 ° measurement range)
Repeat accuracy:	<0.2 % (360 ° measurement range)
Status LED:	Green: reference point at 2.1° Red: sensor break detection , Control power supply

<b>4 ... 20 mA current loop</b>	
Output load:	max. 500 ohms at 24 V DC
Settling time:	< 1 ms (R <sub>load</sub> = 400 Ohm, 25 °C)
Short-circuit proof outputs: when the supply voltage is correctly applied, then output to output is short-circuit protected. But not output to 0 V or to +Ub	
Supply voltage and sensor output signal are not galvanically isolated.	

#### Example (output signal profile):

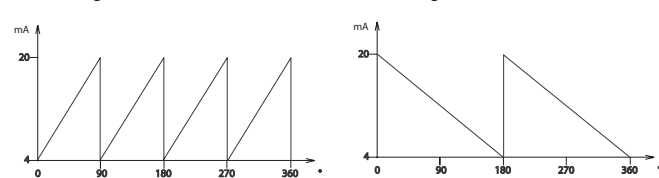

#### Terminal assignment:

<b>Sig.:</b>	0V	+Ub	+I	-I
<b>Col.:</b>	WH	BN	GN	YE

#### Electrical characteristics voltage interface 0 ... 10 V:

<b>Sensor:</b>	
Supply voltage:	20 ... 30 V DC
Current consumption: (w/o output load):	typ 27 mA, max. 47 mA
Reverse polarity protection at power supply (Ub):	Yes
Measuring range:	45°, 90°, 180° or 360° (see also table „measuring range“)
Linearity(25 °C)	<1.0 % (360 ° measurement range)
Repeat accuracy:	<0.2 % (360 ° measurement range)
Status LED:	Green: reference point at 2.1°

<b>0 ... 10 V voltage output</b>	
Current output:	max. 10 mA
Settling time:	< 1 ms (R <sub>last</sub> = 1 KOhm, 25 °C)
Short-circuit proof outputs:	Yes <sup>2)</sup>
Supply voltage and sensor output signal are not galvanically isolated.	

- <sup>2)</sup> Short circuit to 0V or to output, only one channel at a time, supply voltage correctly applied

#### Example (output signal profile):

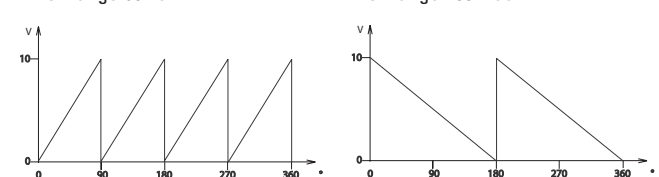

#### Terminal assignment:

<b>Sig.:</b>	0V	+Ub	+Uo	-Uo
<b>Col.:</b>	WH	BN	GN	YE

#### General characteristics:

Conforms to CE requirements acc. to EN 61000-6-1, EN 61000-6-4, EN 61000-6-3 and EN 61000-4-8 (behaviour under magnetic influence).

# Rotary Measuring Technology

## Magnetic measurement system

### Absolute Singleturn Encoder Type 3650

#### Dimensions:

ø 36 mm, Synchro flange

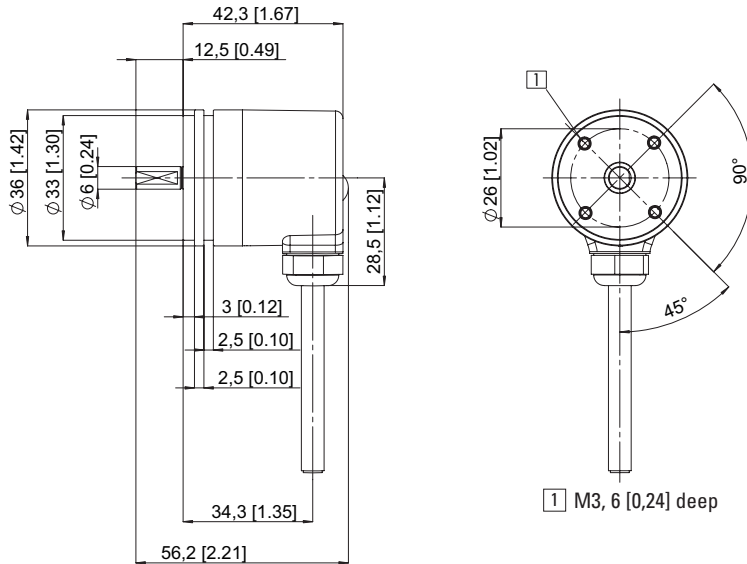

#### Order code:

8 . 3 6 5 0 . **X** **X** **X** **X** . **X** **X** **X** **X** <sup>1)</sup>

Type		Option 1
Flange	<b>2 = Synchro flange</b>	<b>1 = IP67 (IP 69K on request)</b>
Shaft (ø x L)	<b>3 = ø 6 mm x 12,5 mm</b> 5 = ø 6,35 (1/4") mm x 12,5 mm	Option 2
Output circuit / Power supply	<b>2 = SSI/5 ... 30 V DC</b> <b>3 = 4 ... 20 mA/18 ... 30 V DC</b> <b>4 = 0 ... 10 V DC/20 ... 30 V DC</b>	<b>1 = Count direction cw*</b> <b>2 = Count direction ccw*</b>
		Code type and division
		use corresponding table
		Type of connection
		<b>2 = cable radial (1 m PUR)</b>

\*cw = increasing code values when shaft turning clockwise (cw). Top view on shaft.

*Preferred types are indicated in bold*

<sup>1)</sup> Series delivery as from February 2007

#### Code type and division:

**SSI interface**  
**B9 = 9 Bit binary**

**Current interface 4 ... 20 mA**  
45 = 45° measurement range  
90 = 90° measurement range  
18 = 180° measurement range  
**36 = 360° measurement range**

**Voltage interface 0 ... 10 V**  
45 = 45° measurement range  
90 = 90° measurement range  
18 = 180° measurement range  
**36 = 360° measurement range**

#### Measuring range:

Measuring range:	360°	180°	90°	45°
Internal resolution (Measuring range):	9 Bit	8 Bit	7 Bit	6 Bit
	512 steps	256 steps	128 steps	64 steps
Interfaces:	SSI	–	–	–
	4 ... 20 mA	4 ... 20 mA	4 ... 20 mA	4 ... 20 mA
	0 ... 10 V	0 ... 10 V	0 ... 10 V	0 ... 10 V

# Rotary Measuring Technology

## Magnetic measurement system

### Absolute Singleturn Encoder Type 3670

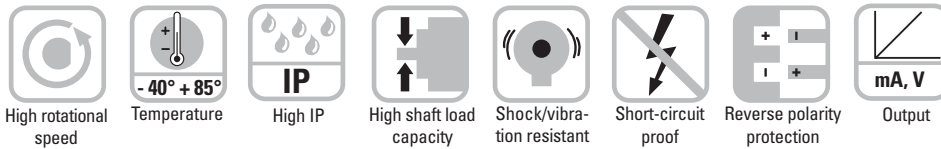

#### Rugged

- Ensures long service life and reliability of the application, no wear  
Non-contact measuring system

- Stays sealed even when subjected to harsh everyday use. Offers security against failures in the field  
Solid die-cast housing with up to IP 69K protection

- Can be used for a wide temperature range without additional expense.  
Wide temperature range (-40 °C ... +85 °C)

- Increased ability to withstand vibration and installation errors. Eliminates machine downtime and repairs.  
High shock resistance (> 500g) and vibration resistance (>30g)

- Can be used in outdoor applications with large fluctuations in temperature.  
Resistant against humidity and condensation.



#### Compact

- Can be used where space is tight  
Overall diameter of only 36 mm

- Compact encoder, suitable for large shafts  
Blind hollow shaft up to 10 mm, shaft up to 6,35 mm

#### Versatile

- Interface: 9-Bit SSI, 4 ... 20 mA, 0 ... 10 V  
One size available for different applications

- Measuring range: 45°; 90°; 180°; 360°:  
Suitable measuring range available for different applications

- Enables simple installation  
Reference point can be identified via LED (green)

- Easy diagnosis in case of fault condition  
Error indication via LED (red)

- Enables simple installation  
Torque stop slot and synchro flange available

#### Mechanical characteristics:

Max. speed:	6000 min <sup>-1</sup>
Starting torque	< 0,06 Nm
Weight:	appr. 0,2 kg
Protection acc. to EN 60 529:	IP 67 (IP 69k on request)
Arbeitstemperaturbereich:	-40 °C ... +85 °C
Materials:	Shaft: stainless steel, Flange: aluminium, Housing: die cast zinc, Cable: PUR
Shock resistance acc. to DIN-IEC 68-2-27:	5000 m/s <sup>2</sup> , 6 ms
Vibration resistance acc. to DIN-IEC 68-2-6:	300 m/s <sup>2</sup> , 10 ... 2000 Hz
Permanent shock resistance acc. to DIN-IEC 68-2-29	1000 m/s <sup>2</sup> , 2 ms
Vibration (broad-band random) to DIN-IEC 68-2-64	5 ... 2500 Hz, 100 m/s <sup>2</sup> - rms

### Absolute Singleturn Encoder Type 3670

#### Electrical characteristics SSI Interface:

<b>Sensor:</b>	
Supply voltage:	5 ... 30 V DC <sup>1)</sup>
Current consumption (w/o output load):	typ 22 mA, max. 41 mA
Reverse polarity protection at power supply (Ub):	Yes
Measuring range:	360°
Resolution/Code:	9 Bit/Binary
Linearity (25 °C)	<1.0 %
Repeat accuracy:	<0.2 %
Data refresh rate:	typ 100 µs
Status LED:	Green, reference point at 2,1°

<b>SSI interface</b>	
Clock speed:	100 kHz ... 1 MHz
Output driver:	RS 485
Monoflop time typ./max.:	16 µs/20 µs
Short circuit proof outputs:	Yes <sup>2)</sup>
Permissible load/channel	typ. 120 Ohm (corresponding RS 485)

- <sup>1)</sup> The supply voltage at the encoder input must not be less than 4.75 V (5 V - 5%)  
<sup>2)</sup> Short circuit to 0V or to output, only one channel at a time, supply voltage correctly applied

#### Terminal assignment:

<b>Sig.:</b>	0V	+Ub	0 V Sens	+Ub Sens	+T	-T	+D	-D
<b>Col.:</b>	WH	BN	BU	RD	GN	YE	GY	PK

#### Electrical characteristics current interface 4 ... 20 mA:

<b>Sensor:</b>	
Supply voltage:	18 ... 30 V DC
Current consumption (w/o output load):	typ 25 mA, max. 42 mA
Reverse polarity protection at power supply (Ub):	Yes
Measuring range:	45°, 90°, 180° or 360° (see also table „measuring range“)
Linearity (25 °C)	<1.0 % (360 ° measurement range)
Repeat accuracy:	<0.2 % (360 ° measurement range)
Status LED:	Green: reference point at 2.1° Red: sensor break detection , Control power supply

#### 4 ... 20 mA current loop

Output load:	max. 500 ohms at 24 V DC
Settling time:	< 1 ms (R <sub>load</sub> = 400 Ohm, 25 °C)
Short-circuit proof outputs: when the supply voltage is correctly applied, then output to output is short-circuit protected. But not output to 0 V or to +Ub	
Supply voltage and sensor output signal are not galvanically isolated.	

#### Example (output signal profile):

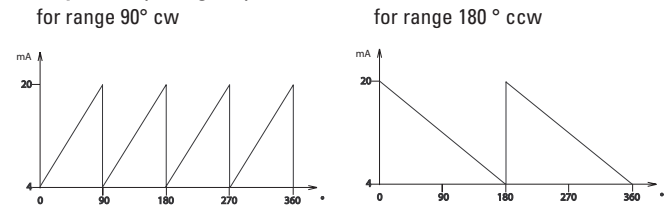

#### Terminal assignment:

<b>Sig.:</b>	0V	+Ub	+I	-I
<b>Col.:</b>	WH	BN	GN	YE

#### Electrical characteristics voltage interface 0 ... 10 V:

<b>Sensor:</b>	
Supply voltage:	20 ... 30 V DC
Current consumption: (w/o output load):	typ 27 mA, max. 47 mA
Reverse polarity protection at power supply (Ub):	Yes
Measuring range:	45°, 90°, 180° or 360° (see also table „measuring range“)
Linearity(25 °C)	<1.0 % (360 ° measurement range)
Repeat accuracy:	<0.2 % (360 ° measurement range)
Status LED:	Green: reference point at 2.1°

#### 0 ... 10 V voltage output

Current output:	max. 10 mA
Settling time:	< 1 ms (R <sub>last</sub> = 1 KOhm, 25 °C)
Short-circuit proof outputs:	Yes <sup>2)</sup>
Supply voltage and sensor output signal are not galvanically isolated.	

- <sup>2)</sup>Short circuit to 0V or to output, only one channel at a time, supply voltage correctly applied

#### Example (output signal profile):

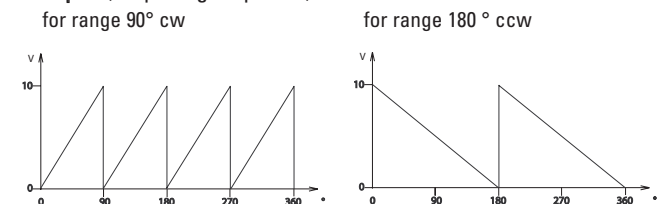

#### Terminal assignment:

<b>Sig.:</b>	0V	+Ub	+Uo	-Uo
<b>Col.:</b>	WH	BN	GN	YE

#### General characteristics:

Conforms to CE requirements acc. to EN 61000-6-1, EN 61000-6-4, EN 61000-6-3 and EN 61000-4-8 (behaviour under magnetic influence).

### Absolute Singleturn Encoder Type 3670

#### Dimensions

ø 36 mm, Flange with long torque stop

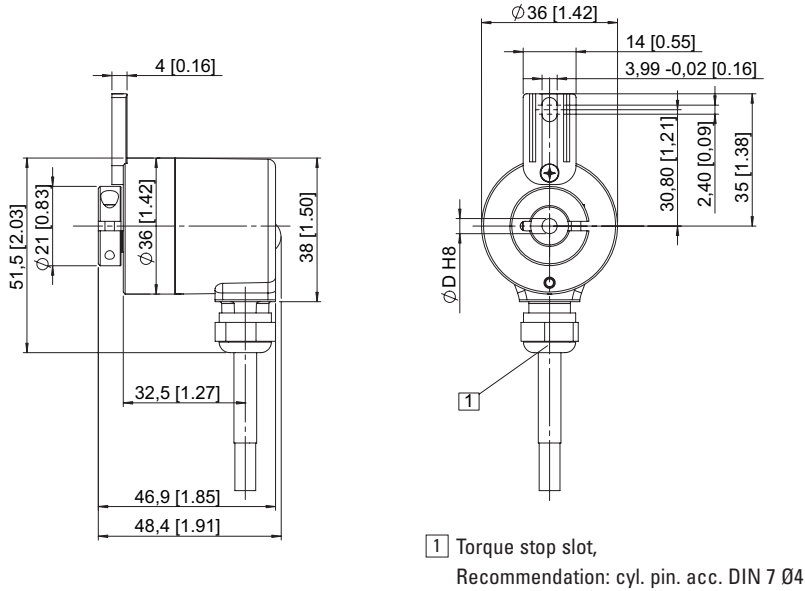

ø 36 mm, Synchro flange

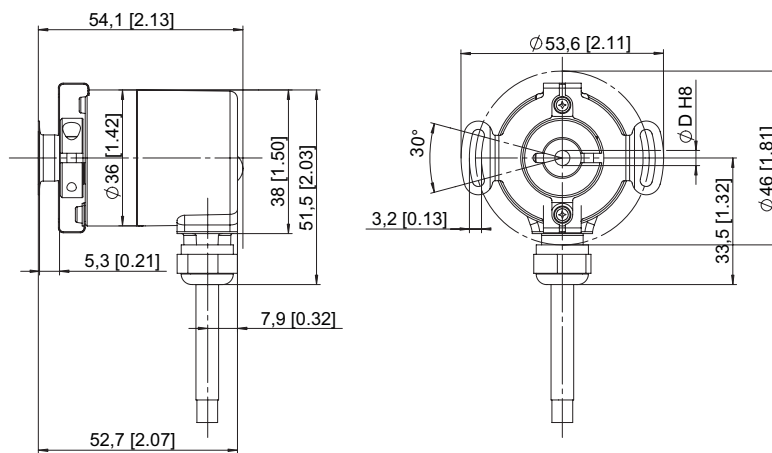

### Absolute Singleturn Encoder Type 3670

Order code:

8 . 3 6 7 0 . X X X X . X X X X <sup>1)</sup>

Type

Flange  
 2 = Flange with long torque stop  
**5 = Flange with stator coupling**

Hollow shaft  
 2 =  $\varnothing$  6 mm  
 3 =  $\varnothing$  6,35 (1/4")  
 4 =  $\varnothing$  8 mm  
 6 =  $\varnothing$  10 mm

Output circuit / Power supply  
 2 = SSI/5 ... 30 V DC  
 3 = 4 ... 20 mA/18 ... 30 V DC  
 4 = 0 ... 10 V DC/20 ... 30 V DC

Option 1  
**1 = IP 67 (IP 69k on request)**

Option 2  
**1 = Count direction cw\***  
 2 = Count direction ccw\*

Code type and division  
 use corresponding table

Type of connection  
**2 = Cable radial (1 m PUR)**

\*cw = increasing code values when shaft turning clockwise (cw). Top view on shaft.

<sup>1)</sup> Series delivery as from February 2007

*Preferred types are indicated in **bold***

#### Code type and division:

**SSI interface**  
**B9 = 9 Bit binary**

**Current interface 4 ... 20 mA**  
 45 = 45° measurement range  
 90 = 90° measurement range  
 18 = 180° measurement range  
**36 = 360° measurement range**

**Voltage interface 0 ... 10 V**  
 45 = 45° measurement range  
 90 = 90° measurement range  
 18 = 180° measurement range  
**36 = 360° measurement range**

#### Measuring range:

Measuring range:	360°	180°	90°	45°
Internal resolution (Measuring range):	9 Bit	8 Bit	7 Bit	6 Bit
	512 steps	256 steps	128 steps	64 steps
Interfaces:	SSI	–	–	–
	4 ... 20 mA	4 ... 20 mA	4 ... 20 mA	4 ... 20 mA
	0 ... 10 V	0 ... 10 V	0 ... 10 V	0 ... 10 V