

Rotary Measuring Technology

Rotary magnetic measurement system

Absolute Singleturn Encoder Type 2450 (Shaft) / 2470 (Hollow shaft)

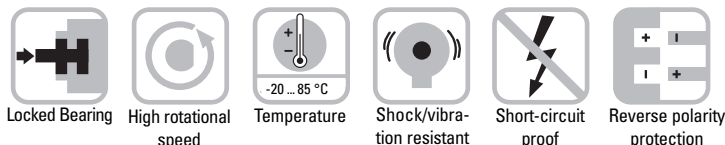

Rugged

- Ensures long service life and reliability of the application, no wear
Non-contact measuring system
- Can be used for a wide temperature range without additional expense.
Wide temperature range (-20 ... +85 °C)
- Robust cable outlet
High strain-relief thanks to multiple clamping



Compact

- Can be used where space is tight
Overall diameter of only 24 mm
Shaft diameter min. 4 mm

Versatile

- High resolution 12 Bit
4096 different positions at 360 °
- Wide power supply range
5 V DC or 8 ... 30 V DC
- Flexible connection of power supply
Radial or axial cable connection

Mechanical characteristics:

Speed:	max. 12 000min ⁻¹
Rotor moment of inertia:	approx. 0.1 x 10 ⁻⁶ kgm ²
Starting torque:	<0.001 Nm
Radial load capacity of shaft:	10 N
Axial load capacity of shaft:	20 N
Weight:	approx. 0.06 kg
Protection acc. to EN 60529:	IP 64 housing side, IP64 shaft side on request
Working temperature:	-20° C ... +85 °C ²⁾
Shaft	stainless steel, clamping ring MS 58 ¹⁾
Shock resistance acc. to DIN-IEC 68-2-27	1000 m/s ² , 6 ms
Vibration resistance acc. to DIN-IEC 68-2-6:	100 m/s ² , 55 ... 2000 Hz

²⁾ Non-condensing

Electrical characteristics SSI Interface:

Sensor:	
Supply voltage:	5 (±0,4) V DC or 8 ... 30 V DC ¹⁾
Current consumption (w/o output load):	< 40 mA
Reverse polarity protection at power supply (U _b):	Yes
Measuring range:	360°
Resolution/Code:	12 Bit/Grey
Linearity (25 °C):	<1.5 °
Repeat accuracy:	<0.1°
Data refresh rate:	typ 100 µs

SSI interface

Clock speed:	100 kHz ... 750 kHz
Output driver:	RS 485
Monoflop time typ./max.:	16 µs/20 µs
Short circuit proof outputs:	Yes ²⁾
Permissible load/channel	typ. 120 Ohm (corresponding RS 485)

¹⁾ The supply voltage at the encoder input must not be less than 4.75 V (5 V - 5%)

²⁾ Short circuit to 0V or to output, only one channel at a time, supply voltage correctly applied

General characteristics:

Conforms to CE requirements acc. to EN 61000-6-1, EN 61000-6-4, EN 61000-6-3 and EN 61000-4-8 (behaviour under magnetic influence).
RoHS compliant acc. to EU guideline 2002/95/EG

Terminal assignment:

Sig.:	0V	+U _b	+T	-T	+D	-D
Col.:	WH	BN	GN	YE	GY	PK

Absolute Singleturn Encoder Type 2450 (Shaft) / 2470 (Hollow shaft)

Dimensions shaft version:

Flange Type 1 (ø24 mm)

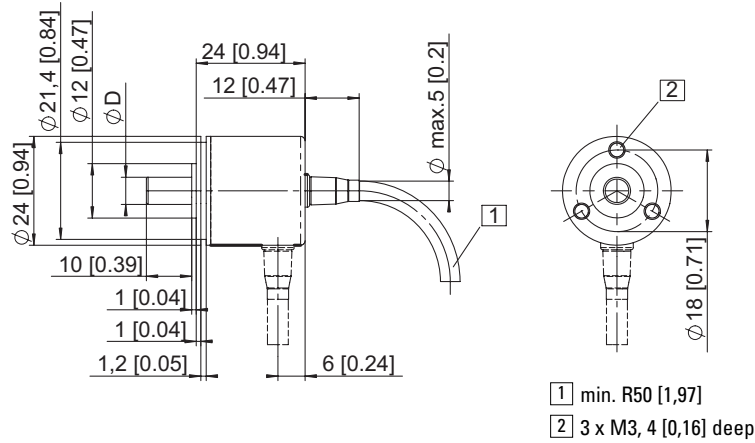

Flange Type 2 (ø 30 mm)

Flange Type 3 (ø 28 mm)

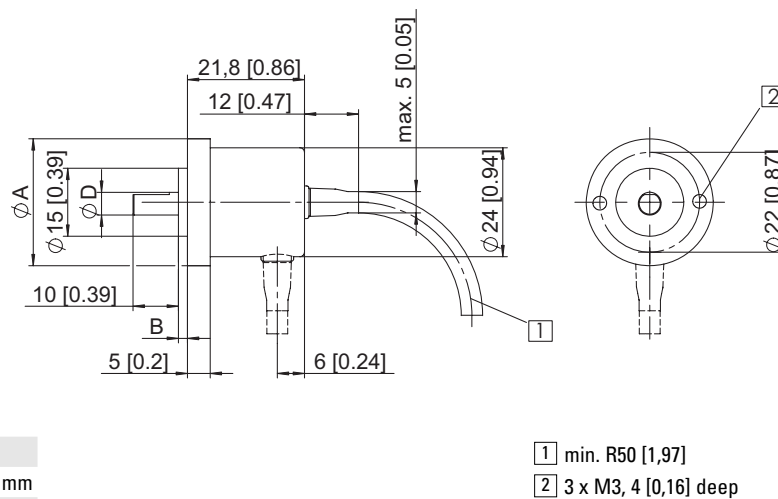

Mounting advice:

The flanges and shafts of the encoder and drive should not both be rigidly coupled together at the same time! We recommend the use of suitable couplings (see Accessories section).

Flange Type	2	3
A	ø 30 mm	ø 28 mm
B	3 mm	2 mm

Order code shaft version:

8.2450.XXXX.G121

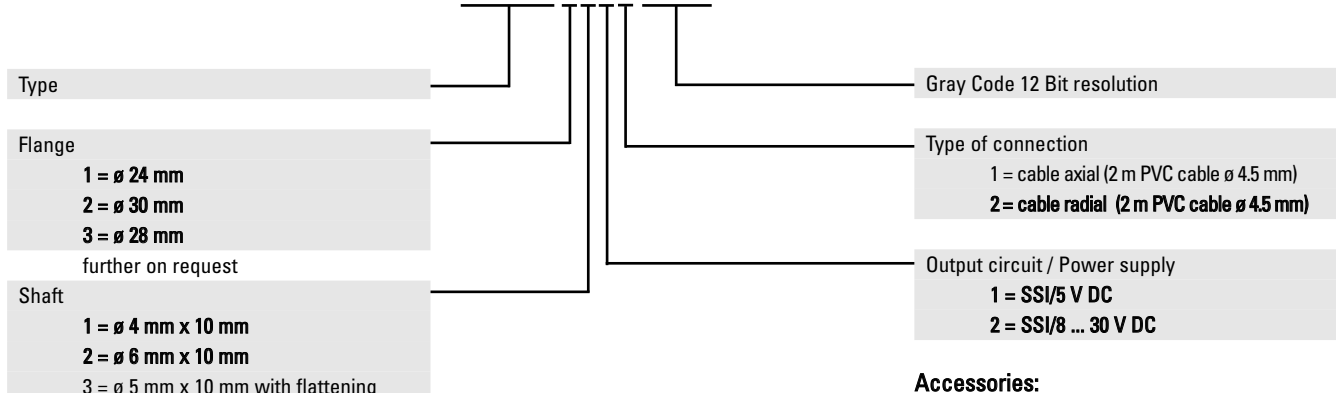

Accessories:

Cables and connectors, also pre-assembled, can be found in the chapter Connection Technology
Mounting attachments and couplings can be found in the chapter Accessories

Absolute Singleturn Encoder Type 2450 (Shaft) / 2470 (Hollow shaft)

Dimensions hollow shaft version:

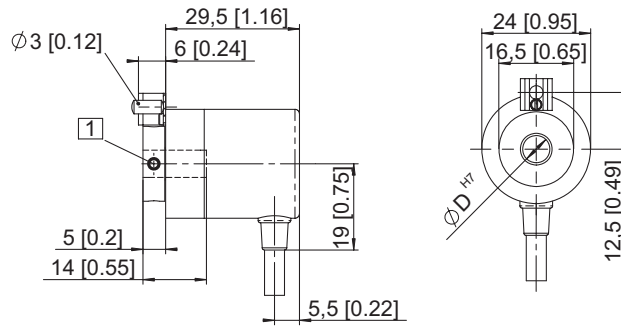

1 4 x M3 DIN 915 - SW15

Mounting advice:

The flanges and shafts of the encoder and drive should not both be rigidly coupled together at the same time! We recommend the use of suitable couplings (see Accessories section).

Order code hollow shaft version:

8.2470.1XXX.G121

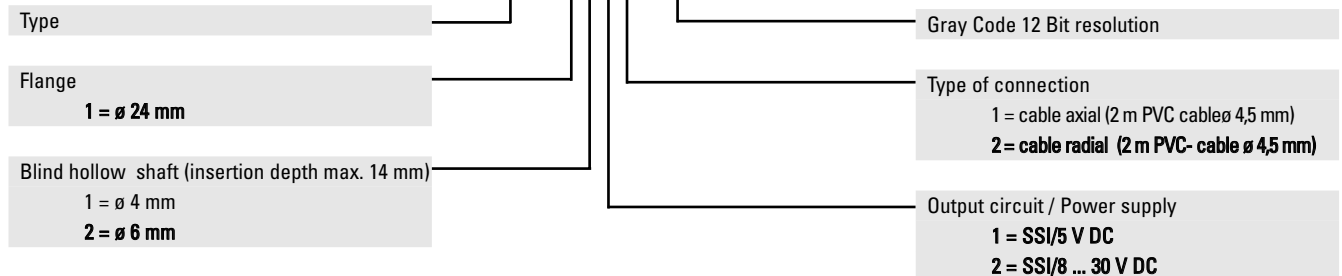

Accessories:

Cables and connectors, also pre-assembled, can be found in the chapter Connection Technology

Mounting attachments and couplings can be found in the chapter Accessories