

The best of the made in Italy

Red Beam

Photoelectric security system

Operator's Manual

HECTO  **S**ystems



Fulfilled Rules
EN 61496-1
IEC 61496-2



Summary

2 - Introduction	pag. 3
3 - Use	pag. 4
3.1 - Operating range	pag. 4
3.2 - Precautions and limits of use	pag. 5
4 - Operating principle	pag. 6
4.1 - Projector	pag. 6
4.2 - Receiver	pag. 6
4.2.1 - Indicator lights functions	pag. 7
5 - Outputs	pag. 7
6 - Operation mode	pag. 8
6.1 - Manual mode	pag. 8
6.2 - Semi-automatic mode	pag. 8
6.3 - Automatic mode	pag. 8
7 - Inputs	pag. 8
7.1 - TEST input	pag. 8
7.2 - RESTART input	pag. 8
8 - AL01 power supply unit / AC02 safety relay control unit	pag. 9
9 - Self-control and interruption conditions	pag. 9
9.1 - Safety system	pag. 9
9.2 - Operation interruption	pag. 9
9.3 - Broken-down barrier	pag. 9
9.4 - Automatic function for correcting sensitivity	pag. 9
10 - Installation	pag. 10
10.1 - Fixing accessories	pag. 10
10.2 - Procedure carried out using the HTB5-ST18 brackets	pag. 11
11 - Choice of the correct model according to the needs	pag. 12
11.1 - Distance from the dangerous area	pag. 12
12 - Dimensional rates	pag. 13
13 - Product schedules	pag. 14
13.1 - Schedules and wiring diagram of the RED BEAM system	pag. 14
13.2 - HTB5 - HTBL5 - HTBS5 Models	pag. 15
13.3 - HTB3 - HTBL3 - HTBS3 Models	pag. 20
13.4 - HTBR5 - HTBLR5 - HTBSR5 Models	pag. 25
13.5 - HTBR3 - HTBLR3 - HTBSR3 Models	pag. 28
13.6 - HTBU5 Models	pag. 31
14 - Sweep systems	pag. 34
14.1 - Mirrors with wall fixing	pag. 34
14.2 - Mirror holder columns and barrier holders	pag. 35
15 - Maintenance	pag. 36
15.1 - Operating notes	pag. 36
15.2 - Daily maintenance	pag. 36
15.3 - Periodic maintenance	pag. 36
15.4 - Disposal	pag. 37
16 - Guarantee and conformity declaration	pag. 37
16.1 - Guarantee terms	pag. 37
16.2 - Guarantee validity	pag. 37
16.3 - Guarantee declaration	pag. 37
16.4 - Conformity declaration	pag. 38

2 INTRODUCTION

The present manual is addressed to RED BEAM safety barriers users and has been conceived in order to give detailed information for the correct installation and maintenance of the system. During the installation phase, we advise you to comply with national and local safety norms. The instructions contained in the present manual must be respected; none of its parts, if not well understood, must be interpreted. In case of doubts, do not hesitate to contact either the manufacturer or the distributors.

3 USE

3.1 Operating range

The presence of machines in motion continually exposes operators to the risks ensuing from the access to dangerous areas (for operational measures, repairs and maintenance). From here, the need to implement an effective and differentiated protection system.

RED BEAM safety system guarantees an impenetrable protection.

The different available optical resolutions allow to adapt the protection the part of the body being exposed to danger:

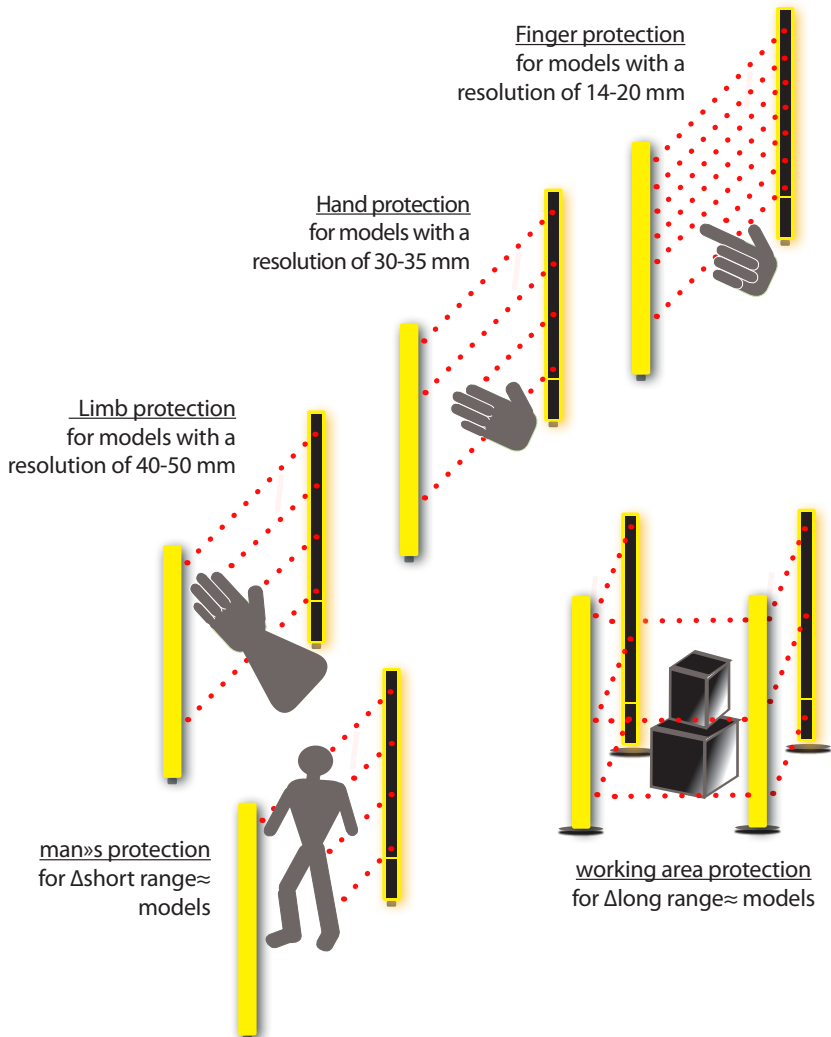

3.2 Precautions and limits of use

The infrared barriers protection system must be used only on machineries that can be immediately stopped. It is not suitable in case the machine activity cannot be stopped during a standard working cycle or within a time being shorter than the cycle one itself.

OSSD outputs cannot be used for directly controlling the members of the machine on which they are installed, but they must absolutely pass through a safety relay such as **HTB5-AC02** or similar items.

The **HTB5-AL01** power supply unit must be exclusively used to power only the barriers and consequently it must not be shared to power other devices.

The barriers cannot be used in case of excessive steam, dust, and corrosive gases or in areas needing a higher protection compared to the indicated one.

The device running is guaranteed within the lighting limits provided for by the IEC 61496-2 rule. Always check that the external light source does not directly strike the receiver; notably, avoid the latter to be exposed to rapid starter or high-frequency fluorescent lamps light.

Avoid the connecting cables to be housed with the machine high-tension and power ones. Avoid the device use in case the distance between the projector and the receiver can vary over time, even if the maximum distance is not exceeded.

The barrier is not suitable to intercept objects being transparent or not much opaque for the infrared radiation: infrared rays cannot be blocked or just lessened by transparent, semi-transparent or too thin objects.

Furthermore, remember that there are materials being totally opaque for visible radiations but completely transparent for the Infrared ones.

4 OPERATING PRINCIPLE

RED BEAM safety system is mainly made up of two components: a projector and a receiver with one or more impulse infrared beam that, once optically synchronized, create a control immaterial barrier.

4.1 Projector

The projector houses on its length a series of emitters generating infrared beams; the number of the emitted beams is variable and determines the resolution of the barrier itself. It is fitted with a CPU that carries out all barrier control and management functions. In case of functional anomalies the projector is stopped within the response time of the concerned specific model.

On the projector there is a red indicator light (BREAK) that gives information about the projector status:

- Always on:
It is correctly synchronized and works well
- Slow lightning (0.5" on - 0.5" off):
Broken-down sensor
- Fast lightning (0.5" on - 0.2" off):
No dialogue with the receiver.
- Off: not aligned or broken-down.

The indicator light BREAK is useful for the correct alignment of the two units. During installation, the indicator light keeps on blinking indicating, that way, a lack of dialogue. After the centring, it will stay always on while the indicator light SAFE of the receiver will light up.

The projector, once it has received the control from the receiver to start the scanning, switches on each emitter diode for a preset time, with a control function for:

- the current used for the switch-on (it must correspond the one of just one diode)
- the switch-on chain locking with end of chain signal sent by the CPU
- the passage of the chain control signals from the active to the non-active status

4.2 Receiver

The receiver is that element receiving the infrared beams. It is made up of photosensitive items whose number is the same as the one of the diodes being present on the projector. It is fitted with a CPU card carrying out all barrier control and management functions.

Besides the beam interruption, any functional anomaly is enough to stop the receiver within the response time of the device, blocking that way the concerned machine working.

Before each scanning, the receiver controls that the external environmental conditions did not damage its own photoreceivers; then it sends a scanning control to the projector and waits for the first beam to be emitted in the preset time. The control concerns the passage from the active status to the passive one and the scanning chain locking with the emission of the end of chain signal.

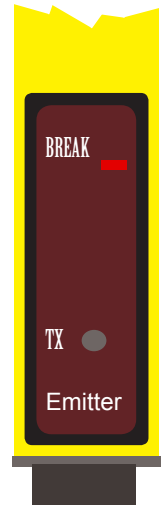

4.2.1 Indicator lights functions

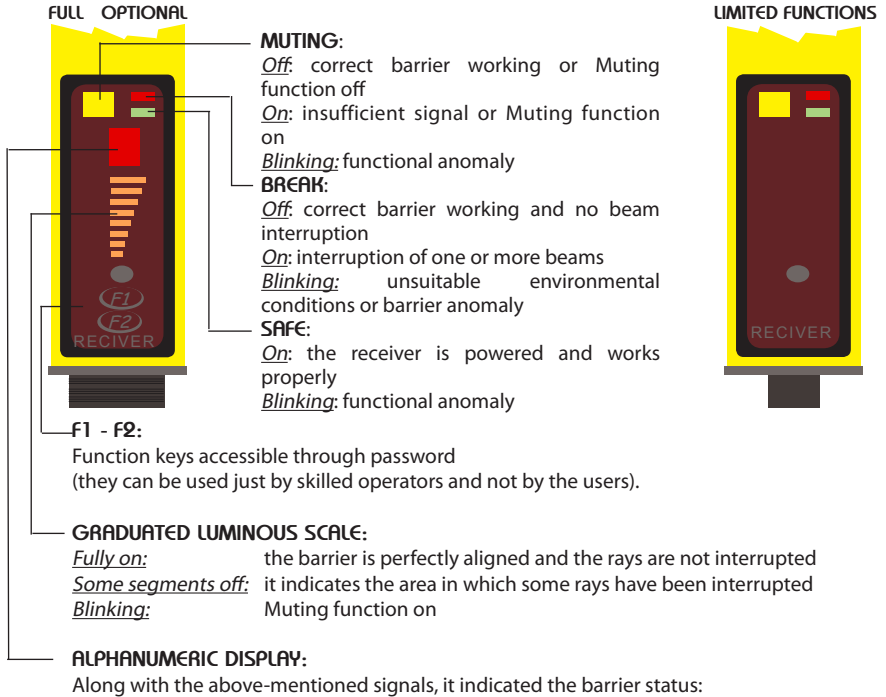

AUTOMATIC **A** The barrier automatically reactivates after each machine shutdown

FAULT **F** Interruption of one or more beams

MANUAL **O** The barrier must be manually restored to a serviceable condition

SEMI-AUTOMATIC **O** The barrier must be manually restored to a serviceable condition

BLOCKING BREAKDOWN **1** Breakdown or anomaly of this utility

BLOCKING BREAKDOWN **2** Anomaly in the selection and first received ray circuit

BLOCKING BREAKDOWN **5** Anomaly in the microprocessor

REDUNDANCY BLOCK **7** Anomaly in the management parameters

Breakdown or anomaly of this utility

5 OUTPUTS

The system is fitted with usually open outputs called OSSD (two for LEVEL 4 safety models and one for LEVEL 2 ones). When the barrier is activated and works properly, the contacts are closed. These outputs must be used to control a safety relay such as HTB5-AC02 or similar items.

MUTING: automatic protection exclusion by the barrier according to the machine cycle. For instance, when some parts of the machine or of the working material have to pass through the barrier without the process to be interrupted. Contrary to the access of a person.

6 OPERATION MODE

6.1. Manual mode

When the system is switched on, the barrier sets to OFF with OSSD off as well.

It is necessary to activate the restart input in order to set the barrier to ON with OSSD on as well.

When the beam is interrupted, the barrier sets again to OFF; the obstacle must be removed and manually reactivate the barrier.

This function is not present in HTBR..., HTBLR... and HTBSR... models

6.2 Semi-automatic mode

When the system is switched on, the barrier sets to OFF with OSSD off as well.

It is necessary to activate the restart input in order to set the barrier to ON with OSSD on as well

When the beam is interrupted, the barrier sets again to OFF; once the obstacle has been removed, the barrier sets automatically to ON after two seconds without further restart activation.

This function is not present in HTBR..., HTBLR... and HTBSR... models

6.3 Automatic mode

When the system is switched on and in the absence of one of more beams interruption, the barrier sets to ON with OSSD on as well.

When the beam is interrupted, the barrier sets again to OFF; once the obstacle has been removed, the barrier sets automatically to ON after two seconds.

7 INPUTS

All the following Inputs are accessible on the receiver connector.

They are on with a voltage of +24Vdc and off when no voltage is present.

For all LEVEL 2 SAFETY models, each input function is active with just one signal.

For all LEVEL 4 SAFETY models, each Input function is active with a double signal, that is both signals must be on or off in a time being not higher than the barrier intervention or cycle one. The presence of a non-coherent status of the two input signals entails a barrier anomaly.

7.1 TEST input

This input is present on the receiver and on the projector. It is not necessary to activate it on both items because they are optically synchronized. The activation of this signal prevents the emission of the synchronism beam by the projector and causes the inhibition of the barrier. This is a useful check to be carried each time the barrier is activated, even if it is important to remember that at each individual scanning, the barrier automatically carries out a check of its own functions.

7.2 RESTART input

This input must not be connected in case of AUTOMATIC configuration of the barrier.

In case of SEMI-AUTOMATIC configuration, this function must be just activated when the system is switched on.

In case of MANUAL configuration, each time the OSSD and the barrier are activated, it is essential to start up the cycle manually activating the Restart signal.

OSSD: output signal commutating device. It is a barrier component being connected to the machine control system. It passes from the on to the off status when the barrier detects an object within its control area.

8 AL01 POWER SUPPLY AND AC02 SAFETY RELAY



The projector and the receiver are powered with a continuous voltage of 24 Volts \pm 20%. The power supply is individually supplied or coupled with a relay safety. Two input voltages, 115 or 230 alternated Volts, are available. The unit is fitted with its own fuse. If the power supply used is the HTB5-AL01, it is absolutely necessary not to use the 24 Vdc output to power additional equipments.



All the 4-type ESPes, being powered with CC, must be used with the relevant individual power supply source In according with the EN 60742 rules

9 SELF-CONTROL AND INTERRUPTION CONDITIONS

9.1 Safety system

The self-control system continuously checks the correct functioning of the circuits of the projector and the receiver. This check is carried out within the cycle of each Infrared beam complete scanning. In case of anomalies, the built-in system being present in the receiver deactivates the outputs making the machine passing from a danger to a safety condition.

The 4-type barrier is fitted with specific redundancy circuits whose aim is to check not only the correct barrier signals progress, but also the decision circuits one.

9.2 Operation interruption

It is the condition of the safety system that automatically activates when anomalies occur.

9.3 Broken-down barrier

Condition being determined by a breakdown.

Activating the diagnostic programme pressing the receiver keypad, details of the detected trouble are displayed.

In case of Broken-down Barrier, the receiver opens the OSSD output contacts. In case of Broken-down Barrier, the projector stops the emission of all luminous channels.

The HTB5-AC02 control unit always reacts deactivating the ending interruption devices.

9.4 Automatic function for correcting sensitivity

Sensitivity is inversely proportional to light intensity (- light + sensitivity).

The following are the factors that decrease the received light intensity: the increase in the operational distance, the presence of dust or opaque bodies that can minimize the Infrared beam.

10 INSTALLATION

During the installation process there are no restraints in terms of inclination, but it is important to respect the direction indicated by the arrows on the plate. In order to respect the scanning direction of the infrared beams, the receiver and the projector must have the same course and the same direction of the arrows.

10.1 Fixing accessories

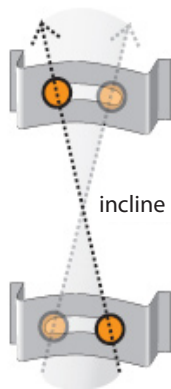

HTB5 - ST18

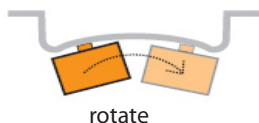

The **HTB5-ST18** "cradle-type" fixing bracket allows to adjust the barrier position, properly inclining and rotating the projector and the receiver. These items are optional ones and are supplied in a specific quantity, that is four parts for each barriers couple.



HTB5 - ST19
Angle fixing bracket

The **HTB5-ST19** "angle-type" bracket allows to place the barrier at 90° compared to the fixing point. These items are optional ones and are supplied in a specific quantity, that is four parts for each barriers couple.

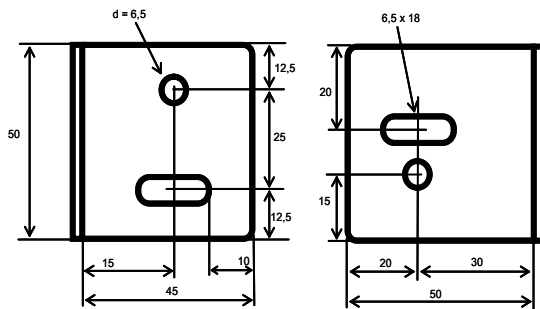

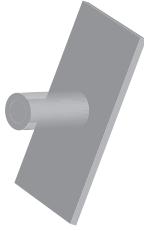

HTB5 - ST17

It is a sliding bracket fitted with a mounting trunnion.

It is supplied with the barrier including 4 parts and the relevant fixing nuts.

10.2 Procedure carried out using the HTB5-ST18 brackets

Fix the brackets to the wall that will have to support the element so as to obtain a distance being equal to $\frac{1}{4}$ of the total receiver length up and to $\frac{1}{4}$ down.

Introduce the brackets in the relevant pins; screw without completely tightening.

Assemble all the supplied components following the sequence indicated in the picture. Tighten the HTB5-ST17 ties just after having perfectly centred the two items.

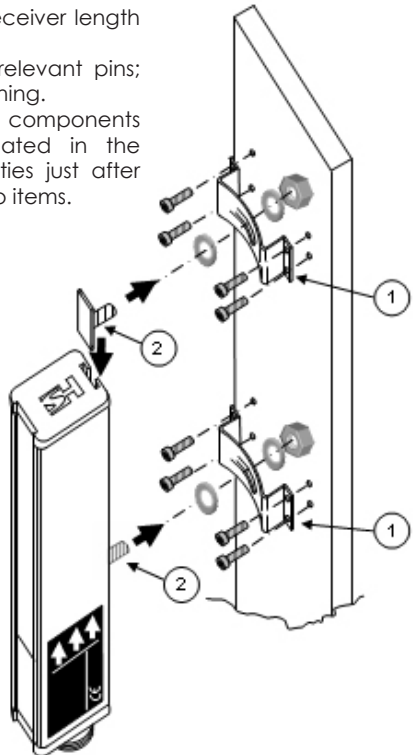

11 CHOICE OF THE CORRECT MODEL ACCORDING TO THE NEEDS

Determine the height of the area to be protected, identify the model having the higher length compared to the necessary one according to the type of protection needed.

If the required height is higher than the one of the available models, use two systems with two control units.

In this case, assemble a projector and a receiver being alternated on one side and on the other.

NEVER PLACE TWO PROJECTORS OR RECEIVERS TOGETHER ON THE SAME SIDE.

11.1 Distance from the dangerous area

The distance of the protection barrier from the dangerous area has to be determined considering different factors, as showed in the following table:

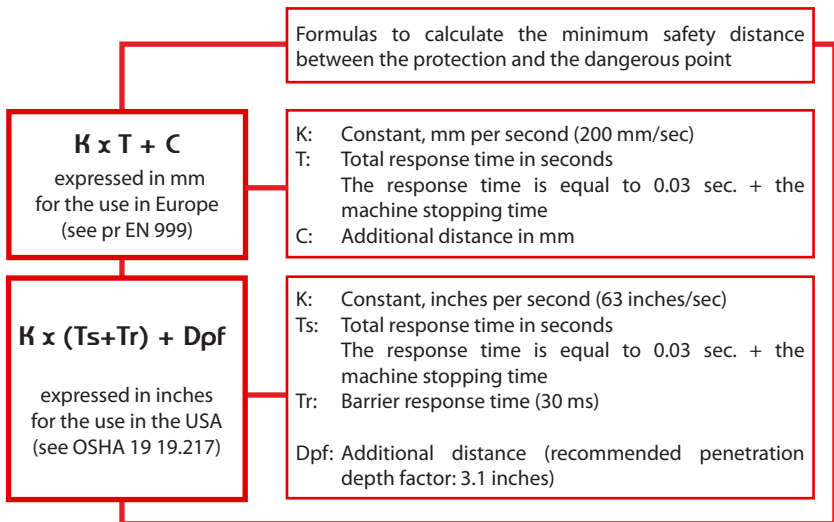

12 DIMENSIONS RATES

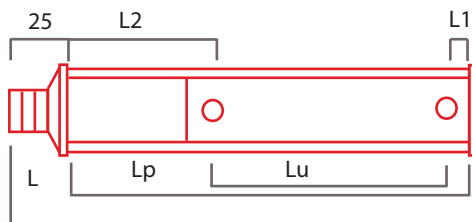
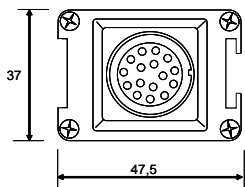

BARRIERS MODEL				LENGTHS (mm)								
Prefix	L If with lens:	If reduced: R	Type	Length usable (cm)	Resolution (mm)	Beams						
						Lu	n°	passo	L1	L2	Lp	L
HTB	() or L	R	3 or 5	15	14	150	16	10	10	85	240	270
					20	140	8	20	20			
					30							
					35							
					40							
				50	120	4	40	40				
				30	14	310	32	10	10	85	400	430
					20	300	16	20	20			
					30							
					35							
					40							
				50	280	8	40	40				
				45	14	470	48	10	10	85	560	590
					20	460	24	20	20			
					30							
					35							
					40							
				50	440	12	40	40				
				60	14	630	64	10	10	85	720	750
					20	620	32	20	20			
					30							
					35							
					40							
				50	600	16	40	40				
				75	14	790	80	10	10	85	880	910
					20	780	40	20	20			
					30							
					35							
					40							
				50	760	20	40	40				
				90	14	950	96	10	10	85	1040	1070
					20	940	48	20	20			
					30							
					35							
					40							
				50	920	24	40	40				
				105	30	1100	56	20	20	85	1200	1230
					35	1110	38	30	20			
					40							
					50							
				1080	28	40	40					
				120	30	1260	64	20	20	85	1360	1390
					35							
					40							
					50	1240	32	40	40			
				135	30	1420	72	20	20	85	1520	1550
					35	1410	48	30	30			
					40							
50												
1400	36	40	40									
150	30	1580	80	20	20	85	1680	1710				
	35	1590	54	30	10							
	40											
	50											
1560	40	40	40									

BARRIERS MODEL COMPOSITION ACRONYM						LENGTHS (mm)				
Prefix	Short R.: S Long R.: U	If reduced: "R"	Type	Length usable (cm)	Number of Beams	Lu	L1	L2	Lp	L
HTB	S or U	R (only for the model S)	3 or 5	16	1	-	45	120	160	190
				30	2	300	45	120	460	490
				45	2	450	45	120	610	640
					3					
				60	3	600	45	120	760	790
				75	3	750	45	120	910	940
					4					
				90	3	900	45	120	1060	1090
					4					
				105	3	1050	45	120	1210	1240
					4					
				120	3	1200	45	120	1360	1390
					4					
				135	3	1350	45	120	1510	1540
					4					
				150	4	1500	45	120	1660	1690
				165	4	1650	45	120	1810	1840
				180	4	1800	45	120	1960	1990
195	4	1950	45	120	2110	2140				

In the case of a 4-type barrier, the activation of an input, the other being deactivated or vice versa, entails the barrier stop within a time being equal to the declared intervention time

13 PRODUCT SCHEDULES

13.1 Schedules and wiring diagram of the RED BEAM system











The following pages will present some schedules containing detailed information about products according to the model.

Each schedule is made up of:

- a recapitulatory table indicating the main features
- wiring diagrams about the different connection configurations

13.2 HTB5 - HTBL5 - HTBS5 MODELS

RECEIVER CONNECTION

PIN	COLOUR	DESTINATION		PIN	COLOUR	
1-J1	violet	ossd 2 (n.a)		ossd 2	10-J1	red
2-J1	pink	ossd 1 (n.a)		ossd 1	3-J1	yellow
4-J1	black	ground				
5-J1	brown	+ 24 Vdc				
6-J1	light-blue	0 Volt				
7-J1	grey	rs -		to the projector	3-J2	yellow
8-J1	white/yellow	rs gnd		to the projector	7-J2	grey
9-J1	grey/pink	rs +		to the projector	8-J2	white
11-J1	white	In-test 1		+ 24 Vdc		
12-J1	green	In-test 2		+ 24 Vdc		
13-J1	red/light blue	In-muting 2		+ 24 Vdc		
14-J1	green/brown	In-muting 1		+ 24 Vdc		
15-J1	white/green	In-restart 2		+ 24 Vdc		
16-J1	yellow/brown	In-restart 1		+ 24 Vdc		



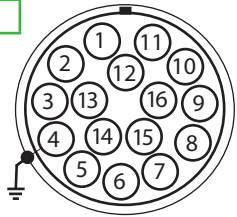

N.B.
Connect just in case
of synchronism via
cable

Front view
of J1 connector
HTB5-CV02R



IMPORTANT:
*always use the screened cable and
be sure it is connected to the ground*

PROJECTOR CONNECTION

PIN	COLOUR	DESTINATION		PIN	COLOUR	
3-J2	yellow	rs gnd		to the receiver	7-J1	grey
7-J2	grey	rs -		to the receiver	8-J1	white/yellow
8-J2	white	rs +		to the receiver	9-J1	grey/pink
9-J2	pink	In - test		+ 24 Volt		
4-J2	red	ground				
5-J2	brown	+ 24 Vdc				
6-J2	light-blue	0 Volt				

N.B.
Connect just in case
of synchronism via
cable

Front view
of J2 connector
HTB5-CV02P

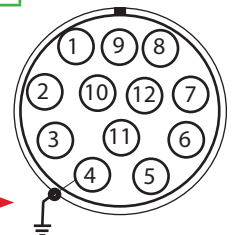

IMPORTANT:
*always use the screened cable and
be sure it is connected to the ground*

TECHNICAL SPECIFICATIONS

Net capacity	HTB5 and HTB5S: 0,1-5 mt HTBL5: 0,3 - 17 mt
Response time	HTB5 and HTBL5 < 30ms HTB5S < 50ms
Outputs	2 current-protected outputs NO - IC max 1A dc@30V
Inputs	RESTART - MUTING - TEST
Power supply	+ 24 Vdc ± 20%
Absorption	0,4 A max
Operating temperature	- 10° + 60° C
Protection level	IP 65
Connection	12 and 16 poles M23 circular connector

Example of diagram with optical synchronization
 without HTB5-AC02 safety relay

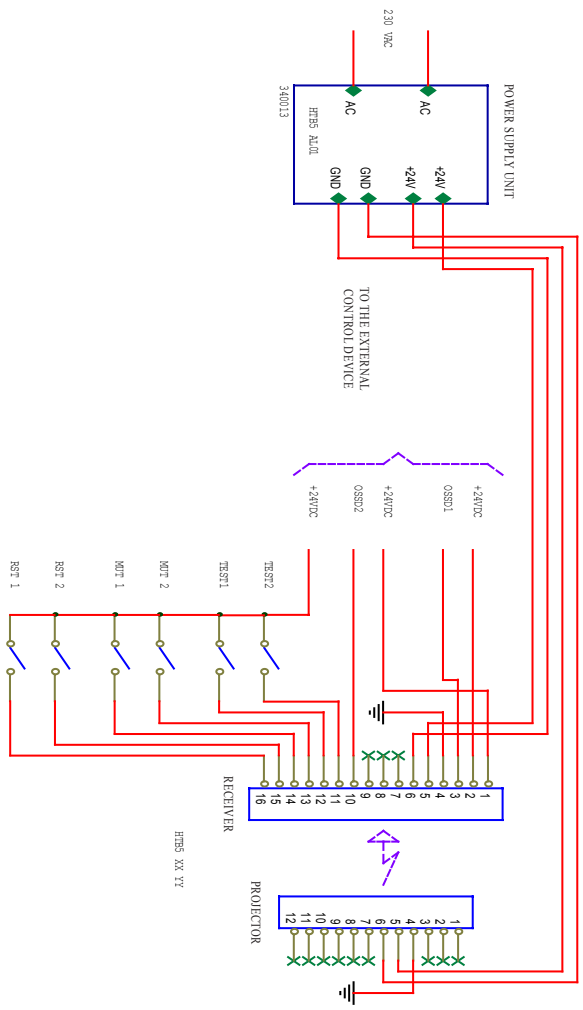

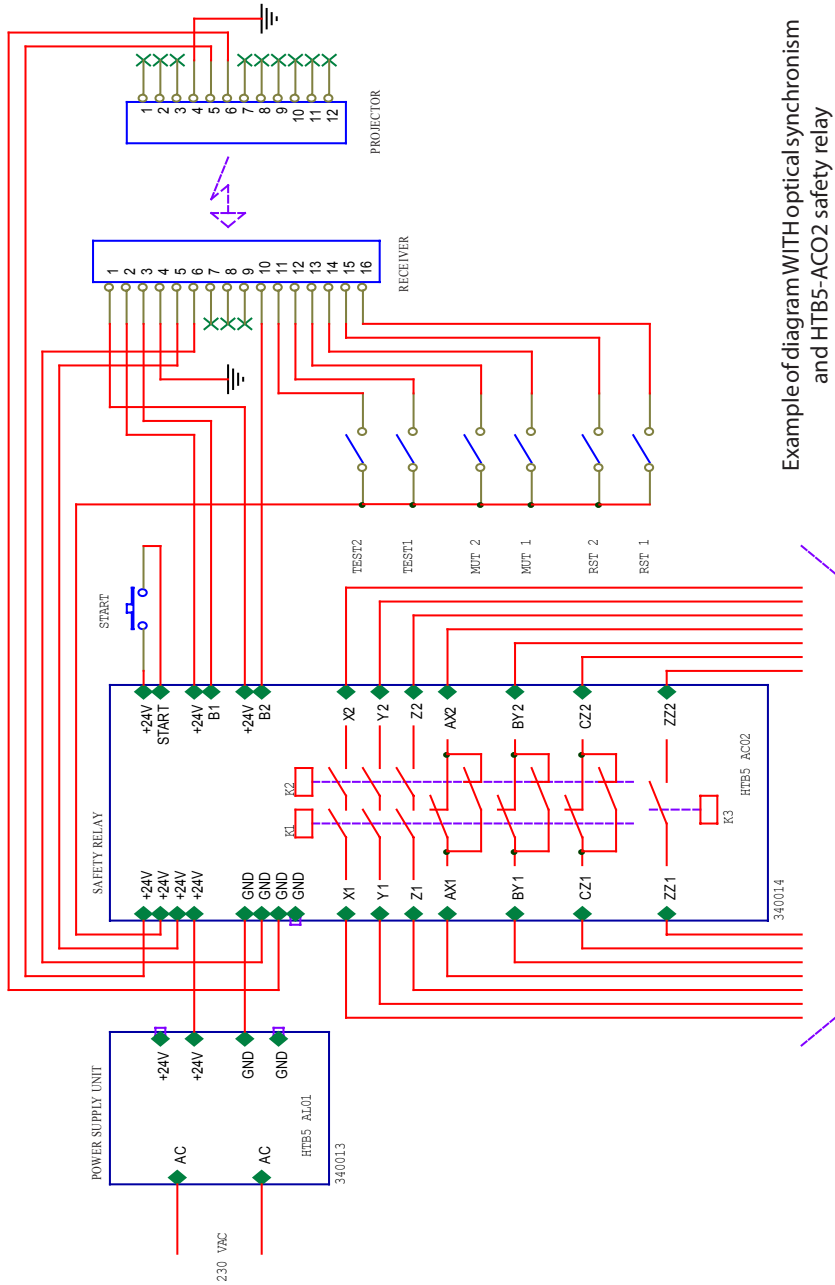

Example of diagram WITH optical synchronism and HTB5-ACO2 safety relay

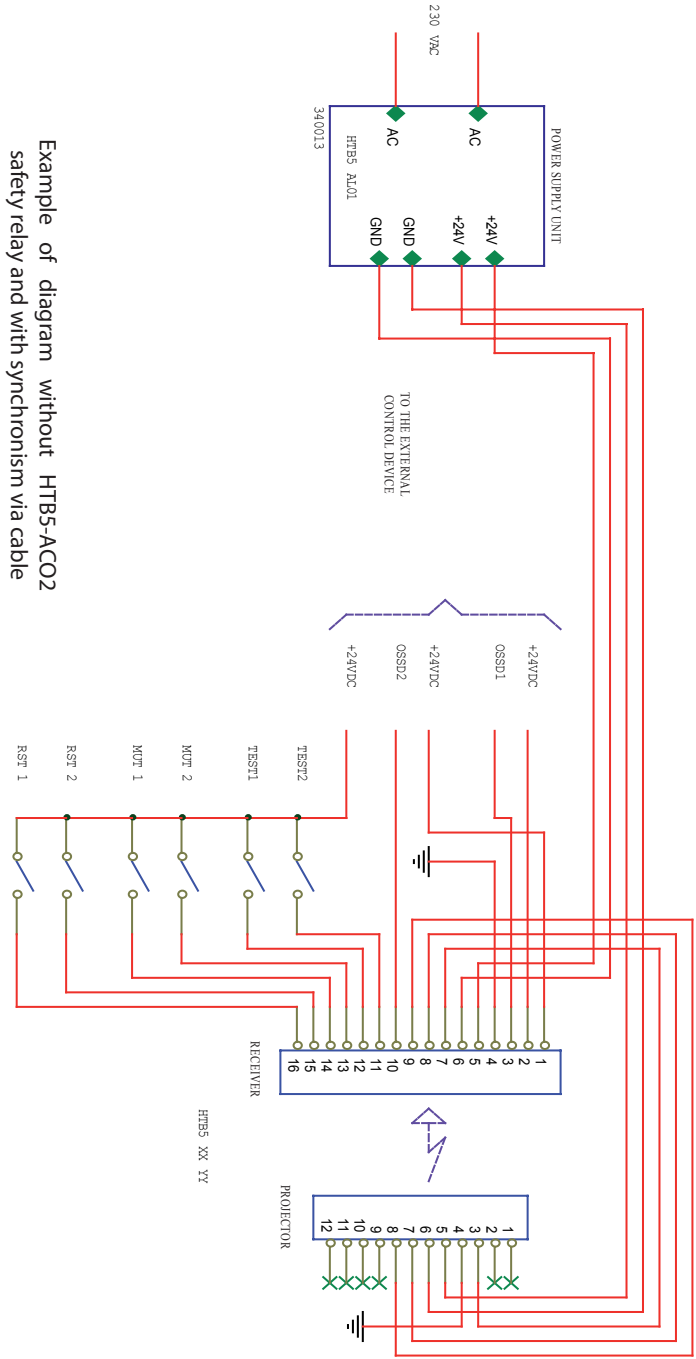



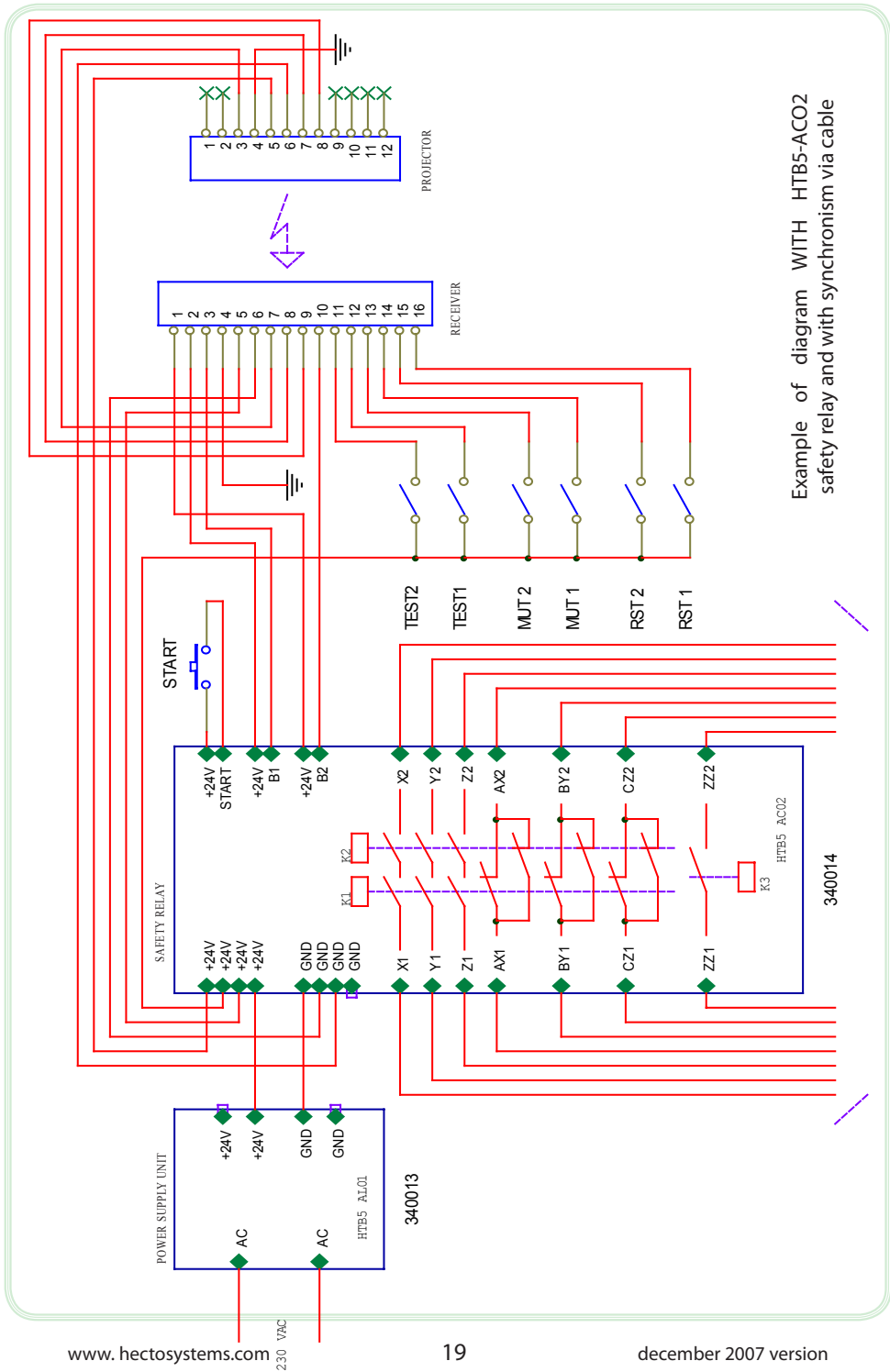



Example of diagram without HTB5-ACO2 safety relay and with synchronism via cable



Example of diagram WITH HTB5-ACO2 safety relay and with synchronism via cable

13.3 HTB3 - HTBL3 - HTBS3 MODELS

RECEIVER CONNECTION

PIN	COLOUR	DESTINATION		PIN	COLOUR
2-J1	pink	ossd 1 (n.a.)	 ossd 1	3-J1	yellow
4-J1	black	ground			
5-J1	brown	+ 24 Vdc			
6-J1	light blue	0 Volt			
7-J1	grey	rs -	 to the projector	3-J2	yellow
8-J1	white/yellow	rs gnd	 to the projector	7-J2	grey
9-J1	grey/pink	rs +	 to the projector	8-J2	white
11-J1	white	In-test 1	 + 24 Vdc		
14-J1	green/brown	In-muting 1	 + 24 Vdc		
16-J1	yellow/brown	In-restart 1	 + 24 Vdc		



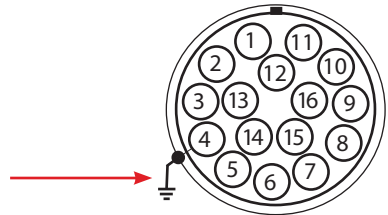

N.B.
Connect just in case
of synchronism via
cable

Front view
of J1 connector
HTB5-CV02R

IMPORTANT:
*always use the screened cable and
be sure it is connected to the ground*



PROJECTOR CONNECTION

PIN	COLOUR	DESTINATION		PIN	COLOUR
3-J2	yellow	rs gnd	 to the receiver	7-J1	grey
7-J2	grey	rs -	 to the receiver	8-J1	white/yellow
8-J2	white	rs +	 to the projector	9-J1	grey/pink
9-J2	pink	In - test	 + 24 Volt		
4-J2	red	ground			
5-J2	brown	+ 24 Vdc			
6-J2	light blue	0 Volt			

N.B.
Connect just in case
of synchronism via
cable

Front view
of J2 connector
HTB5-CV02P

IMPORTANT:
*always use the screened cable and
be sure it is connected to the ground*

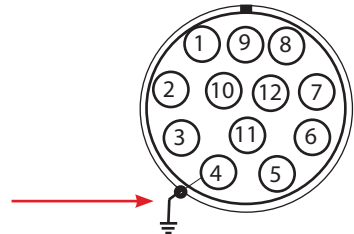

TECHNICAL SPECIFICATIONS

Net capacity	HTB3 and HTBS3 : 0,1-5 mt HTBL3 : 0,3 - 17 mt
Response time	HTB3 and HTBL3 < 30ms HTBS3 < 50ms
Outputs	1 current-protected outputs NO - I max 1A dc@30V
Inputs	RESTART - MUTING - TEST
Power supply	+ 24 Vdc ± 20%
Absorption	0,4 A max
Operating temperature	- 10° + 60° C
Protection level	IP 65
Connection	12 and 16 poles M23 circular connector

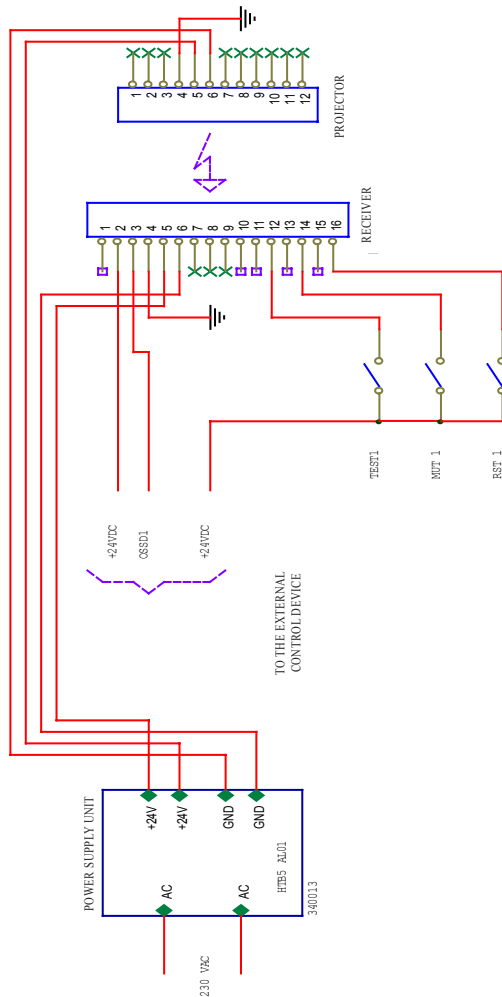

Example of diagram with optical synchronism without HTB5-ACO2 safety relay

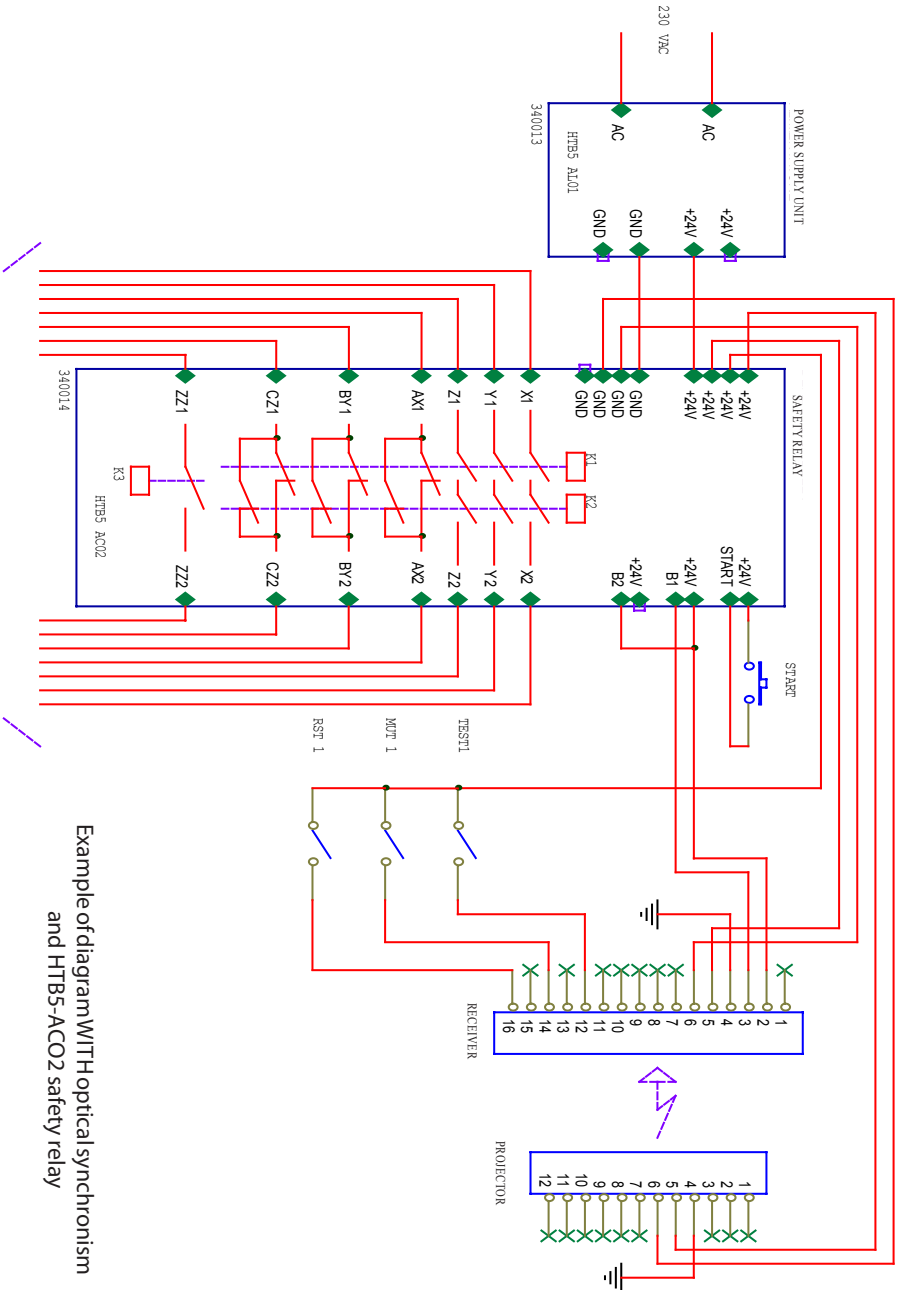

Example of diagram with optical synchronism and HTB5-ACO2 safety relay

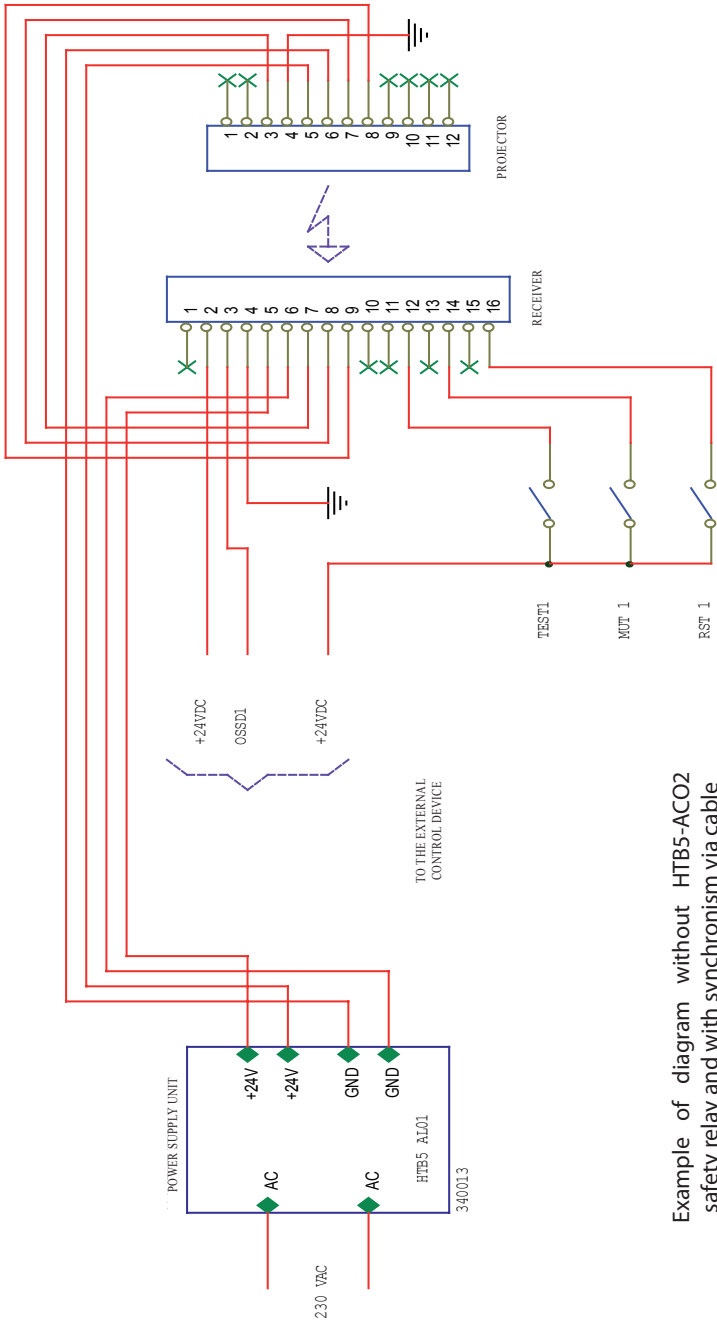

Example of diagram without HTB5-ACO2 safety relay and with synchronism via cable

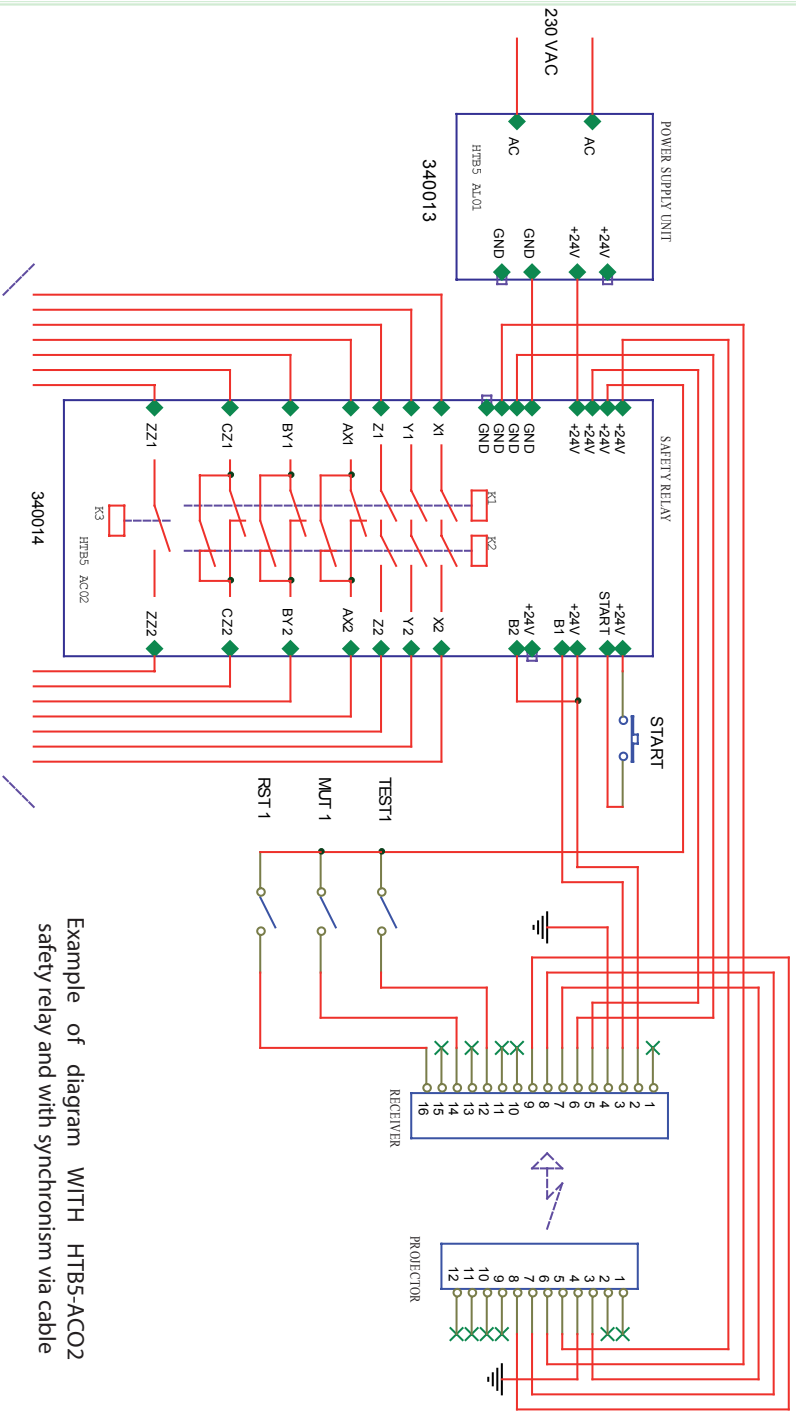

Example of diagram WITH HTB5-ACO2 safety relay and with synchronization via cable

13.4 HTBR5 - HTBLR5 - HTBSR5 MODELS

RECEIVER CONNECTION

PIN	COLOUR	DESTINATION
1-J1	brown	0 Volt
2-J1	white	+ 24 Vdc
3-J1	light blue	In-test (if used, refer it to +24Vdc)
4-J1	black	Not connected
5-J1	grey	ground (to be connected together with the sheathing)

Front view of J1 connector HTB5-CV02P

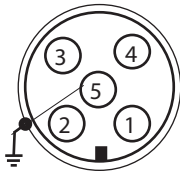

IMPORTANT:
always use the screened cable and be sure it is connected to the ground

PROJECTOR CONNECTION

PIN	COLOUR	DESTINATION
1-J2	brown	0 Volt
2-J2	white	+ 24 Vdc
3-J2	light blue	N.O. output
4-J2	black	N.O. output
5-J2	grey	ground (to be connected together with the sheathing)

N.B.
 Outputs 3 and 4 can be referred to 0 Volts, on demand

Front view of J2 connector HTB5-CV02R

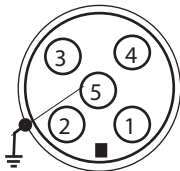

IMPORTANT:
always use the screened cable and be sure it is connected to the ground

TECHNICAL SPECIFICATIONS

Net capacity	HTBR5 and HTBSR5: 0,1-5 mt HTBLR5: 0,3 - 17 mt
Response time	HTBR5 and HTBLR5 < 30ms HTBSR5 < 50ms
Outputs	2 current-protected outputs NO - IC max 1A dc@30V
Inputs	TEST
Power supply	+ 24 Vdc ± 20%
Absorption	0,4 A max
Operating temperature	- 10° + 60° C
Protection level	IP 65
Connection	M12 circular connector with poles

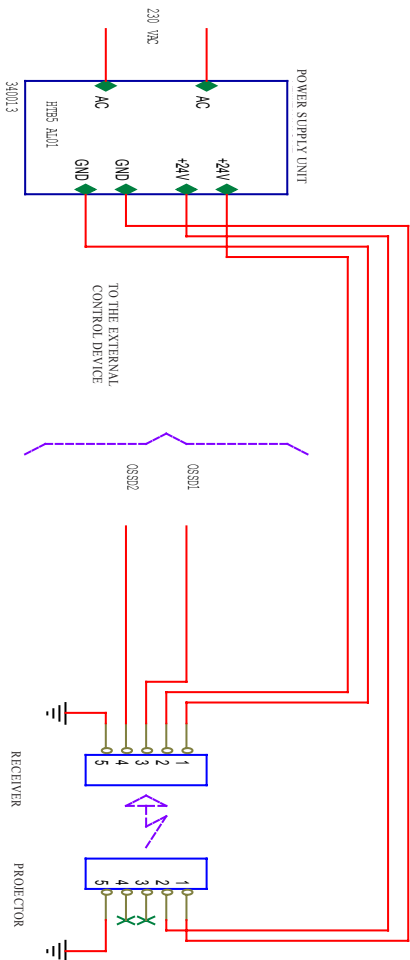

Example of diagram with optical synchronism
without HTBS-ACCO2 safety relay

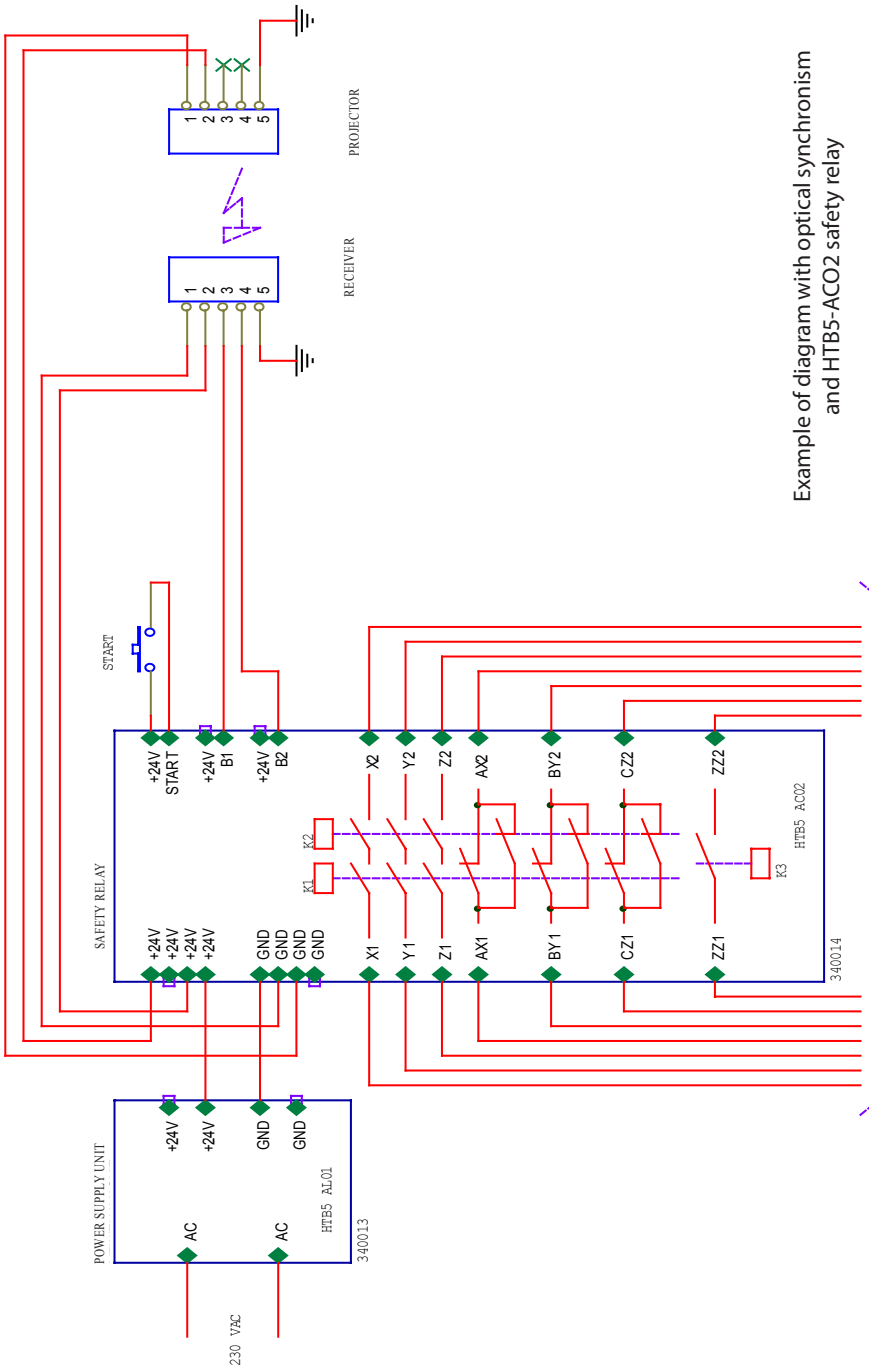

Example of diagram with optical synchronism and HTB5-ACO2 safety relay

13.5 HTBR3 - HTBLR3 - HTBSR3 MODELS

RECEIVER CONNECTION

PIN	COLOUR	DESTINATION
1-J1	brown	0 Volt
2-J1	white	+ 24 Vdc
3-J1	light blue	In-test (if used, refer it to +24Vdc)
4-J1	black	Not connected
5-J1	grigio	ground (to be connected together with the sheathing)

Front view of J1 connector HTB5-CV02P

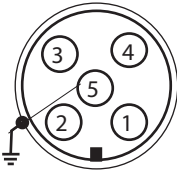

IMPORTANT:
always use the screened cable and be sure it is connected to the ground

PROJECTOR CONNECTION

PIN	COLOUR	DESTINATION
1-J2	brown	0 Volt
2-J2	white	+ 24 Vdc
3-J2	light blue	N.O. output
5-J2	grigio	ground (to be connected together with the sheathing)

N.B.
 Outputs 3 and 4 can be referred to 0 Volts, on demand

Front view of J2 connector HTB5-CV02R

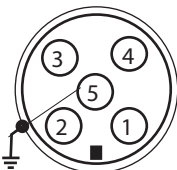

IMPORTANT:
always use the screened cable and be sure it is connected to the ground

TECHNICAL SPECIFICATIONS

Net capacity	HTBR3 and HTBSR3 : 0,1-5 mt HTBLR3 : 0,3 - 17 mt
Response time	HTBR3 and HTBLR3 < 30ms HTBSR3 < 50ms
Outputs	1 current-protected outputs NO - IC max 1A dc@30V
Inputs	TEST
Power supply	+ 24 Vdc \pm 20%
Absorption	0,4 A max
Operating temperature	- 10° + 60° C
Protection level	IP 65
Connection	M12 circular connector with poles

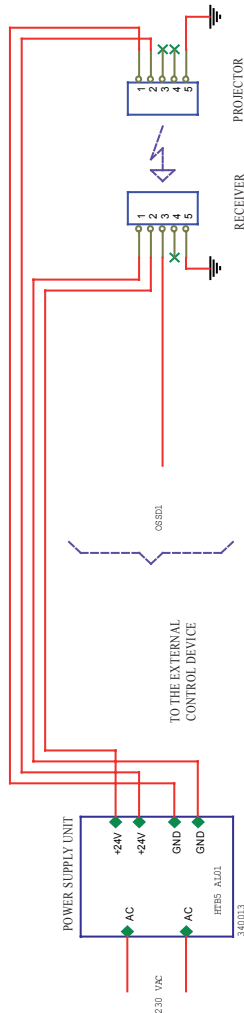



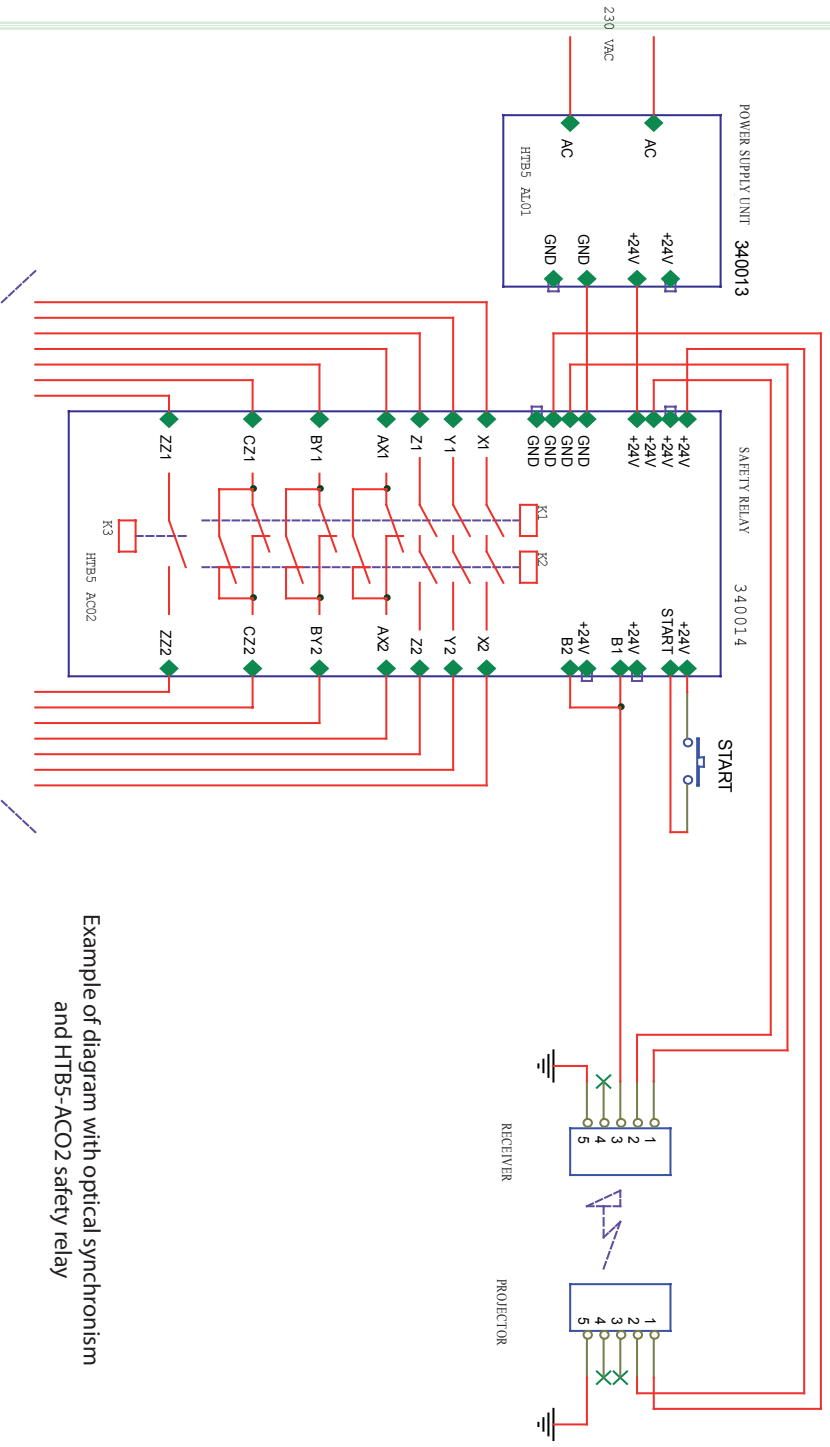







Example of diagram with optical synchronism
without HTB5-ACO2 safety relay



Example of diagram with optical synchronism and HTBS-ACO2 safety relay

13.6 HTBU5 MODELS

RECEIVER CONNECTION



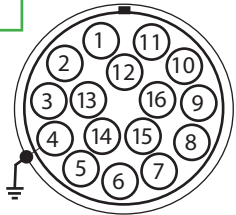

PIN	COLOUR	DESTINATION		PIN	COLOUR	
1-J1	violet	ossd 2 (n.a)		ossd 2	10-J1	red
2-J1	pink	ossd 1 (n.a)		ossd 1	3-J1	yellow
4-J1	black	ground				
5-J1	brown	+ 24 Vdc				
6-J1	light blue	0 Volt				
7-J1	grey	rs -		to the projector	3-J2	yellow
8-J1	white/yellow	rs gnd		to the projector	7-J2	grey
9-J1	grey/pink	rs +		to the projector	8-J2	white
11-J1	white	In-test 1		+ 24 Vdc		
12-J1	green	In-test 2		+ 24 Vdc		
13-J1	red/light blue	In-muting 2		+ 24 Vdc		
14-J1	green/brown	In-muting 1		+ 24 Vdc		
15-J1	white/green	In-restart 2		+ 24 Vdc		
16-J1	yellow/brown	In-restart 1		+ 24 Vdc		

Front view
of J1 connector
HTB5-CV02R



IMPORTANT:
*always use the screened cable and
be sure it is connected to the ground*

PROJECTOR CONNECTION

PIN	COLOUR	DESTINATION		PIN	COLOUR	
3-J2	yellow	rs gnd		to the receiver	7-J1	grey
7-J2	grey	rs -		to the receiver	8-J1	white-yellow
8-J2	white	rs +		to the projector	9-J1	grey/pink
9-J2	pink	In - test		+ 24 Volt		
4-J2	red	ground				
5-J2	brown	+ 24 Vdc				
6-J2	light blue	0 Volt				

Front view
of J2 connector
HTB5-CV02P

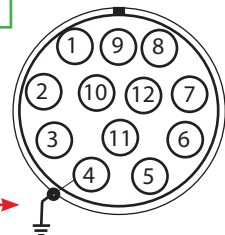

IMPORTANT:
*always use the screened cable and
be sure it is connected to the ground*

TECHNICAL SPECIFICATIONS

Net capacity	HTBUS: 4 - 60 mt
Response time	> 50ms
Outputs	2 current-protected outputs NO - IC max 1A dc/30V
Inputs	RESTART - MUTING - TEST
Power supply	+ 24 Vdc \pm 20%
Absorption	0,4 A max
Operating temperature	- 10° + 60° C
Protection level	IP 65
Connection	12 and 16 poles M23 circular connector

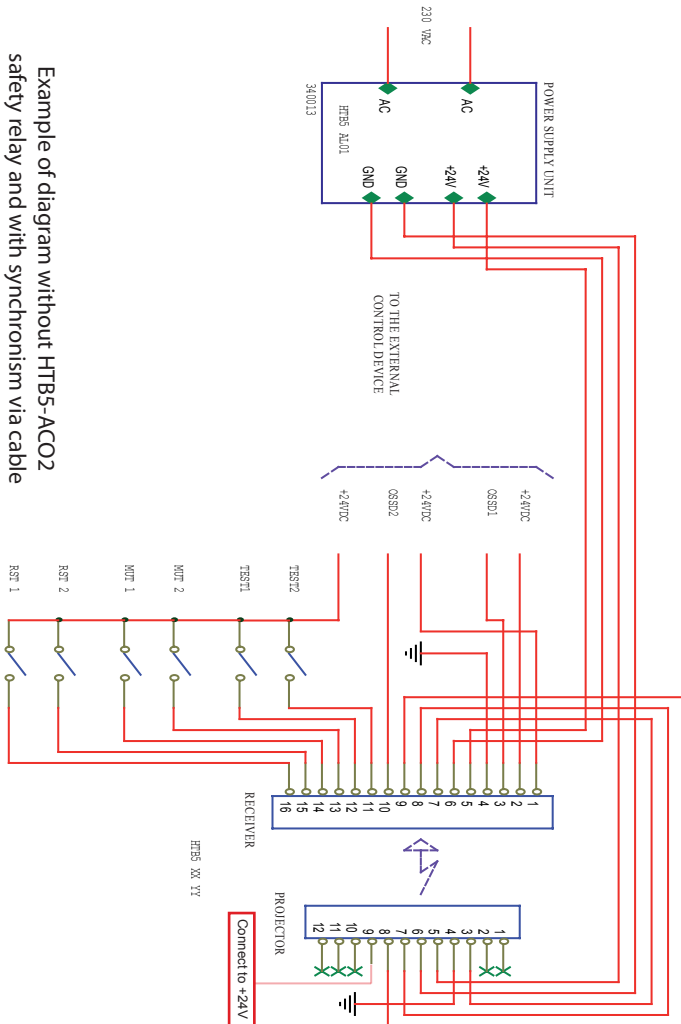

Example of diagram without HTB5-ACO2 safety relay and with synchronism via cable

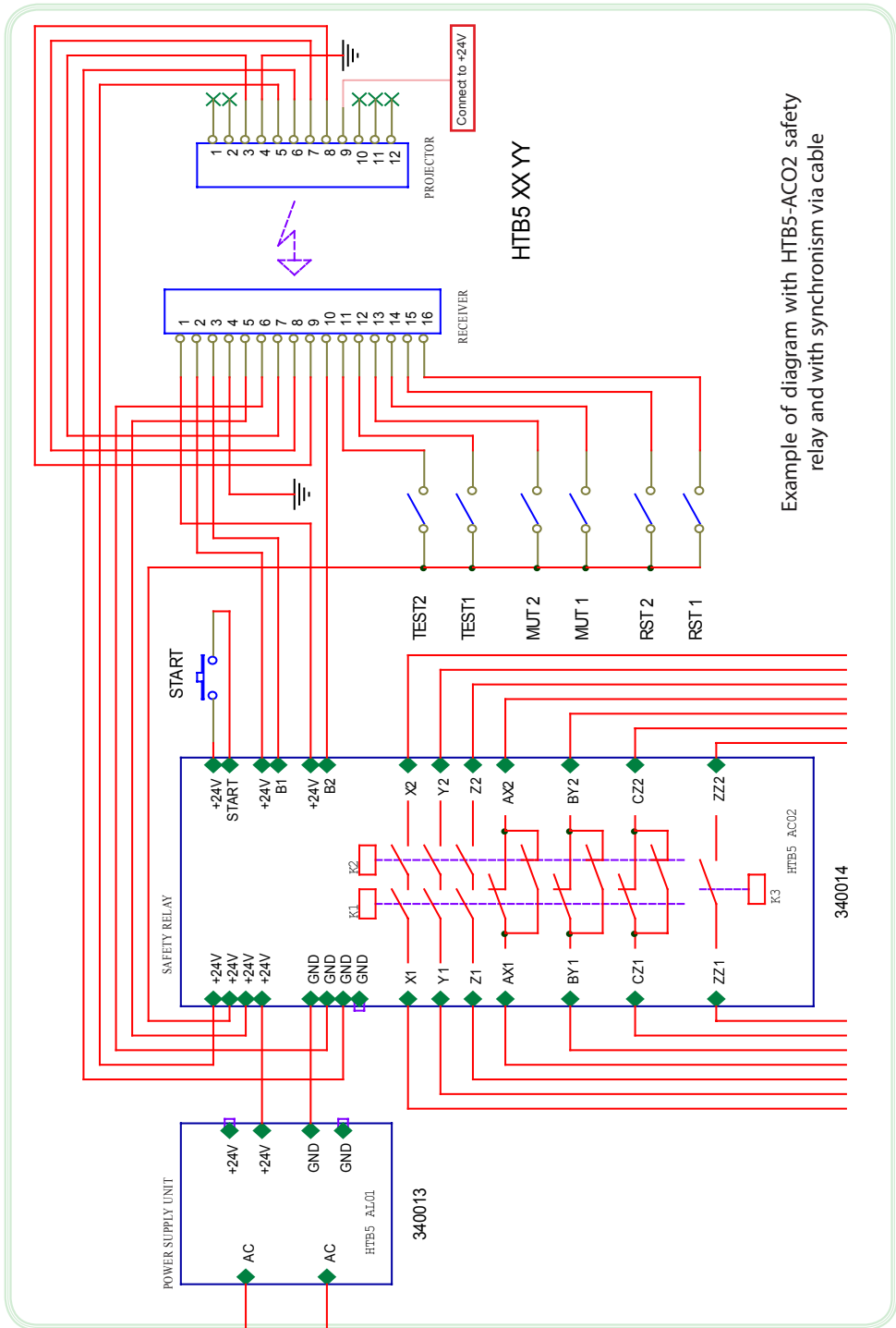

Example of diagram with HTB5-ACO2 safety relay and with synchronization via cable

14 SWEEP SYSTEMS

14.1. Mirrors with wall fixing

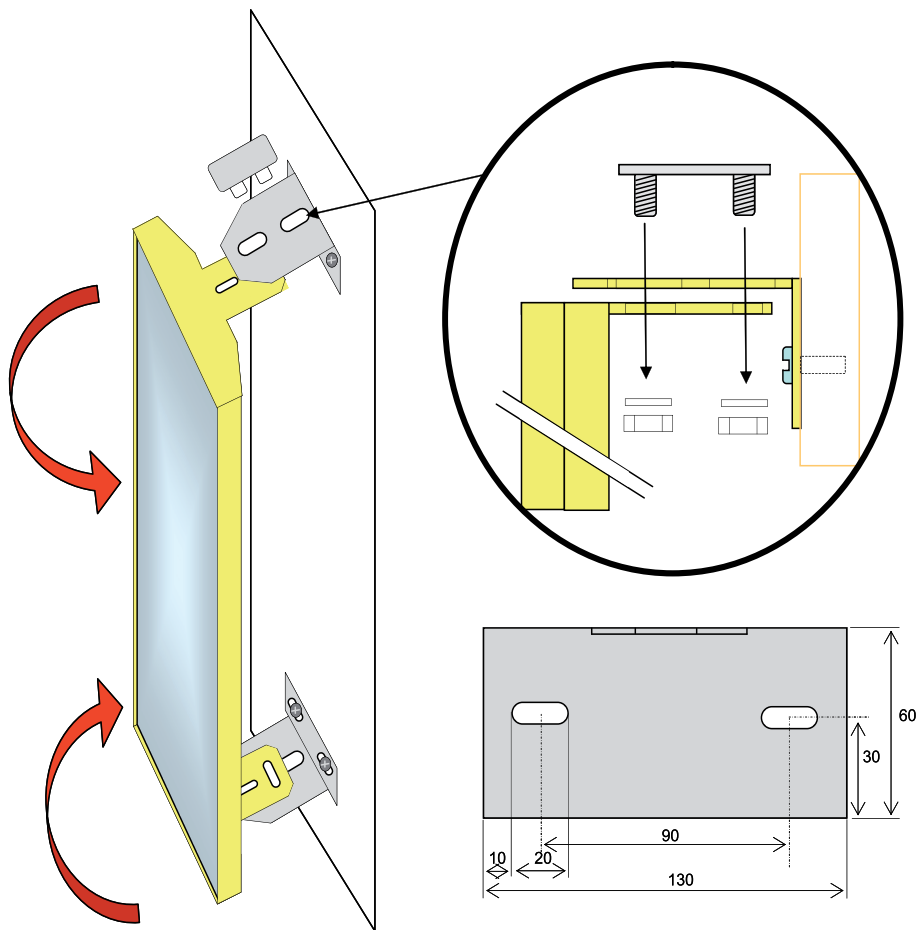

MIRROR HOLDER MODELS	SIZE in mm
HTB5 - SP 55	550 x 130
HTB5 - SP 90	900 x 130
HTB5 - SP 120	1200 x 130

IT IS POSSIBLE TO HAVE DIFFERENT HEIGHTS.... ON DEMAND

14. 2 Mirror holder columns and barrier holders

MIRROR HOLDER MODELS	SIZE in mm
HTB5 - CSP 90	135 x 900
HTB5 - CSP120	135 x 1200
HTB5 - CSP160	135 x 1600

IT IS POSSIBLE TO HAVE DIFFERENT HEIGHTS.... ON DEMAND

BARRIER HOLDER MODELS	SIZE in mm
HTB5 - CPB 90	135 x 900
HTB5 - CPB 120	135 x 1200
HTB5 - CPB 160	135 x 1600

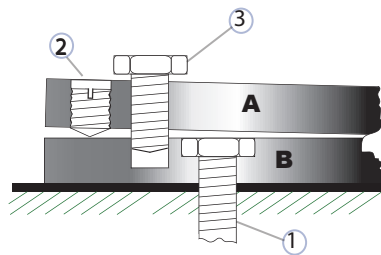
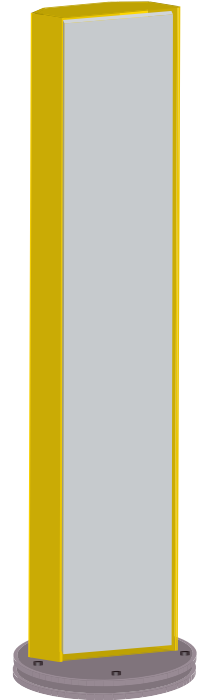

Fixing procedure:

- Plug disc B to the ground using screws ①
- Assemble column A screwing screws ③ without tightening them
- Level the column intervening on pins ②
- Tighten screws ③

15 MAINTENANCE

15.1 Operating notes

Before each use of the machine, make sure that the safety system has been daily checked.

15.2 Daily maintenance

In order to make the barrier keeping the required safety level, it is important to schedule daily maintenance and control procedures to check both the barrier and the environmental and operating condition that must be the same as the initial ones set by the project.

Maintenance programmes have to be scheduled in compliance with local and national applicable rules.

- 1 Energize the receiver controlling that, in its initial phase, all indicator lights are on for at least three consecutive seconds. In case some input signals are on, the coloured LEDs will blink for three seconds, as indicated in the following table:
Green LED: restart signal on
Yellow LED: muting signal on
Red LED: test signal on
- 2 Energize the receiver controlling that, in its initial phase, the red LED is on for at least three consecutive seconds.
- 3 Check that the optical synchronisation between the receiver and the projector properly works. In this case, after the initial test, the red LED on the projector is constantly on indicating, that way, that the normal procedure to activate beams is on. In case of anomalies (lack of optical synchronism) the red LED blinks staying on for 0.5 sec. and off for 1.5 sec.
- 4 Using the specific test stick, interrupt each ray and verify that, on the receiver, the green LED switches off while the red one switches on. In some models... it is possible to check the switching off of the bar display lights on the receiver.

If the barrier is set to work in a semi-automatic or manual mode, check that OSSD outputs are not activated when the test stick is removed, but just after the restarting signal reactivation. In case of automatic mode, this happens just for the first cycle after the starting up.

15.3 Periodic maintenance

Keep the sensitive parts of the projector and of the receiver clean removing oil and dust without damaging their surface; this because, though the presence of an IP65 protection level, oil tends to seep in them entailing anomalies or even short circuits among the electronic components.

Check that the sensitive surfaces are free of scratches or abrasions that can compromise the standard working and consider the possible replacing or repair of the whole equipment.

Check that the connectors are always fully tightened and that on the inside contacts there is no liquid of any kind.

Check the correct barrier orientation using the supplied tools. In case of need, realign the two components.

15.4 Disposal

This symbol being present both on the products and on the supplied documents means that electric and electronic products must not be disposed along with the generic household wastes.

Consequently, the present product cannot be disposed of.

At the end of the life cycle, this product must pass through a specific differentiated waste collection.



16 GUARANTEE AND CONFORMITY DECLARATION

16.1 Guarantee terms

The product has a 12-month guarantee starting from the purchase date that cannot be extended, even if the equipment is not used.

16.2 Guarantee validity

H.E.C.TO. Systems guarantee covers only faults coming from a normal use of the product and will not be valid for other cases, such as negligence, damages due to accidental causes, wrong use, wrong modifications, use of accessories being not consistent with the technical specifications of the product. Furthermore, the guarantee is not valid in case of failures due to the connection of the equipment to different voltages than the indicated ones or due to sudden voltage changes in the network the device is connected to. The same is in case of breakdowns caused by Inductive/electrostatic discharges or discharges due to lightning or to other phenomena being external to the equipment itself.

16.3 Guarantee declaration

For guarantee, we exclusively intend the free mending or replacing of the components that are considered as faulty in terms of manufacturing or material, including the labour.

H.E.C.TO. Systems is not under obligation to mend the faulty product till the customer gives it back.

After 12 months from the purchase, the guarantee lapses. In this case, post-guarantee interventions will be supplied under payment of the replaced parts and of the supplied labour upon estimate of costs. The mending will be carried out only in case of explicit demand by the customer.

In case of any dispute, the court of Torino will be the competent body.



The presence of original labels being properly glued on the facsimile image guarantees the proof of purchase and validates the guarantee

DECLARATION CE OF CONFORMITY

Producer **H.E.C.TO. SYSTEMS s.a.s**
Address **Corso Grosseto 194 - 10148 TORINO - ITALY**

Declairs under the own responsibility that the product Safety Light Curtain
 the models and the versions as in the tables showed below.

Light Curtains Models			
series HTB3		series HTB5	
HTB3	XX YY	HTB5	XX YY
HTBR3	XX YY	HTBR5	XX YY
HTBL3	XX YY	HTBL5	XX YY
HTBLR3	XX YY	HTBLR5	XX YY
XX= Protected High		YY= Resolution	
HTBU3	XX ZZ	HTBU5	XX ZZ
HTBS3	XX ZZ	HTBS5	XX ZZ
HTBSR3	XX ZZ	HTBSR5	XX ZZ
X= Protected High		Z=Number of beam	

Protected High (cm)														
	15	30	45	60	75	90	105	120	135	150	-	-		
Risoluzione YY (mm)	14	•	•	•	•	•	•							
	20	•	•	•	•	•								
	30	•	•	•	•	•		•	•	•				
	35	•	•	•	•	•		•	•	•	•			
	40	•	•	•	•	•		•	•	•	•			
	50	•	•	•	•	•		•	•	•	•			
N° di raggi ZZ		16	30	45	60	75	90	105	120	135	150	165	180	195
	1	•												
	2		•		•	•	•	•	•	•	•			
	3			•	•	•	•	•	•	•	•	•		
	4				•	•	•	•	•	•	•	•	•	•

and the following accessories for the model below listed :

- **HTB5AL01** **Power Supply**
- **HTB5AC02** **Safety Relais**

They belong in the safety devices category according the File IV Machine Norms (98/37/CE) according the italian DPR 459/96.

- They are conform according the File I Machine Norms (98/37/CE), accordinf the italian DPR 459/96. as showed in the Acts nr. 0476 B1 312 10 04, nr. 0476 B1 319 10 05 and **0476 B1 323 02 06** by CERMET (Notified Body nr. CE0476) in Via Cariano, 23 Cadriano di Granarolo 40057 Bologna - Italy
- **They are conform according :**
 - Electromagnetic Compatibility (CEE Norm 89/336 and following norms CEE92/31 and CEE 93/68) according the italian D.lgt Nr. 615/96 (Norm about the unification of the legislations of the member States about the electromagnetic compatibility).

and also declare that the following norms have been appliade :

- CEI EN 61496-1 (1998)
- IEC 61496-2 (1997)
- UNI EN 954-1 (1998)
- UNI EN 292-1 (1992)
- UNI EN 292-2 (1992)

Torino, 17/02/2006

H.E.C.TO. Systems s.a.s.
 AMATO Scabini

H.E.C.TO. SYSTEMS s.a.s. - Corso Grosseto 194 - 10148 TORINO (ITALY)



**CERMET – NOTIFIED CERTIFICATION BODY
EUROPEAN NOTIFIED BODY N. 0476**

Authorized by the Industry, Commerce and Handicraft Ministry by Decree of July 28th, 1994 and Decree of May 21st, 2003, notified to the European Community Committee, issue the following

**TYPE EC EXAMINATION CERTIFICATE
ACCORDING TO THE DIRECTIVE 98/37/EC
N° 0476 B1 312 10 04**

for the following type/s of machine/s:

Trade Designation: Photoelectric safety barriers

Manufacturer: H.E.C.TO. SYSTEMS of Amato Salvatore & C. S.a.s.
Corso Grosseto, 194
10148 TORINO - Italy

Trade mark: H.E.C.TO.

Type/s: Red Beam series HTB5
Red Beam series HTB3

Applicant: H.E.C.TO. SYSTEMS of Amato Salvatore & C. S.a.s.
Corso Grosseto, 194
10148 TORINO - Italy

Issue date: 2004-10-11

General Manager
Ing. Rodolfo Trippodo

This Certificate only refers to the product indicated here above, manufactured according to the technical documentation delivered to CERMET. Any modification made on the product without the prior CERMET's approval makes it void. Any modifications made on the product/s shall be approved by CERMET, in accordance with article 5 of the Annex VI of the Directive 98/37/EC. This certificate does not imply that CERMET shall carry out a control on the production. This Certificate can be reproduced or duplicated integrally only

This Certificate consists of No. 3 sheets in all.

TECHNICAL CHARACTERISTICS:

<i>Model:</i>	Red Beam series HTB5 xx yy ⁽¹⁾ Red Beam series HTB5 xx yy ⁽¹⁾
<i>Year of manufacture:</i>	2004
<i>Use the product is destined for:</i>	The product is destined for the protection of the operator from the dangerous components of machines that can be stopped immediately. It is not suitable for the machines whose operation cannot be stopped during the cycle operation or in a time shorter than the cycle itself.
<i>Operation modes:</i>	<ul style="list-style-type: none"> • Manual • Semi-automatic • Automatic
<i>Safety category:</i>	4 according to EN 954-1 – Type 4 (for HTB5) 2 according to EN 954-1 – Type 2 (for HTB3)
<i>Resolution</i>	14, 20, 30, 35, 40 mm
<i>Beam type and distance</i>	Infrared with distance 10, 20, 30 mm
<i>Protected height</i>	150, 300, 450, 600, 750, 900, 1050, 1200, 1350, 1500 mm
<i>Useful capacity</i>	0,1 ÷ 3,5 m
<i>Supply:</i>	24 Vdc ± 20% (to be used only with AL05 feeder)
<i>Absorbed power:</i>	0.4 A max
<i>Reply time:</i>	< 30 ms up to 48 rays < 50,2 ms up to 96 rays
<i>Inputs:</i>	<ul style="list-style-type: none"> • RESTART • MUTING • TEST
<i>Outputs:</i>	2 safe outputs NA, 1 A max (for HTB5) 1 safe output NA, 1 A max (for HTB3)
<i>Signal</i>	Led
<i>Protection degree:</i>	IP 65
<i>Installation configuration:</i>	See Operation Manual Rev.0
<i>Optional:</i>	<ul style="list-style-type: none"> • Feeder code HTB5 AL 01 • Feeder and safety relay, integrated code HTB5 AC 02 • Projector connecting cable code HTB5 CV 01 • Receiver connecting cable code HTB5 CV 02 • Fastening accessories code HTBS 17, HTBS 18

Note (1): xx is protected height [mm] , yy is resolution [mm]

PRODUCT VERSIONS:

		Protected height xx									
		150 mm	300 mm	450 mm	600 mm	750 mm	900 mm	1050 mm	1200 mm	1350 mm	1500 mm
Resolution yy	14 mm	•	•	•	•	•	•				
	20 mm	•	•	•	•	•	•				
	30 mm	•	•	•	•	•	•	•	•	•	•
	35 mm	•	•	•	•	•	•	•	•	•	•
	40 mm	•	•	•	•	•	•	•	•	•	•

REFERENCES:

This Type EC Examination Certificate is issued regarding :

- Essential Safety and Health requirements indicated in the Annex I of the Directive 98/37/EC, applicable to the safety component/s as per this Type EC Examination Certificate.
- Specification applicable to the following European standards or draft standards :

UNI EN 954-1: 1998	Machinery safety – Parts of the control system connected with the safety. Part 1: Main principles for the design
UNI EN 292-1:1992	Machinery safety – Basic criteria, general design principles. Part 1: Basic terminology, methodology
UNI EN 292-2:1992	Machinery safety – Fundamental concepts, general design principles. Part 2: Technical specifications and principles
CEI EN 61496-1:1998	Machinery safety – Electrosensitive protection equipment. Part 1: General requirements and tests
IEC 61496-2:1997	Safety of machinery – Electro-sensitive protective equipment Part 2: Particular requirements for equipment using active opto-electronic protective devices (AOPDs)

The type has been felt in compliance with the essential safety and health requirements, as established in Annex I of the Machinery Directive 98/37/EC.



CERMET – NOTIFIED CERTIFICATION BODY
EUROPEAN NOTIFIED BODY N. 0476

Authorized by the Industry, Commerce and Handicraft Ministry by Decree of July 28th, 1994 and Decree of May 21st, 2003, notified to the European Community Committee, issue the following

TYPE EC EXAMINATION CERTIFICATE
ACCORDING TO THE DIRECTIVE 98/37/EC
N° 0476 B1 319 10 05

for the following type/s of machine/s:

Trade Designation: Photoelectric safety barriers

Manufacturer: H.E.C.TO. SYSTEMS of Amato Salvatore & C. S.a.s.
Corso Grosseto, 194
10148 TORINO - Italy

Trade mark: H.E.C.TO.

Type/s: Red Beam series HTB5
Red Beam series HTB3

Applicant: H.E.C.TO. SYSTEMS of Amato Salvatore & C. S.a.s.
Corso Grosseto, 194
10148 TORINO - Italy

Dossier CERMET: C05E025

Issue date: 2005-10-28

General Manager
Ing. Rodolfo Trippodo

This Certificate only refers to the product indicated here above, manufactured according to the technical documentation delivered to CERMET. Any modification made on the product without the prior CERMET's approval makes it void. Any modifications made on the product/s shall be approved by CERMET, in accordance with article 5 of the Annex VI of the Directive 98/37/EC. This certificate does not imply that CERMET shall carry out a control on the production. This Certificate can be reproduced or duplicated integrally only

This Certificate consists of No. 3 sheets in all.

TECHNICAL CHARACTERISTICS:

Model:	Red Beam series HTB3, HTB5
Product versions:	HTB3 xx yy, HTB5 xx yy (<i>xx=protected height [mm], yy=resolution [mm]</i>) HTBR3 xx yy, HTBR5 xx yy (<i>xx=protected height [mm], yy= resolution [mm]</i>) HTBL3 xx yy, HTBL5 xx yy (<i>xx=protected height [mm], yy= resolution [mm]</i>) HTBLR3 xx yy, HTBLR5 xx yy (<i>xx=protected height [mm], yy= resolution [mm]</i>)
Year of manufacture:	2005
Use the product is destined for:	The product is destined for the protection of the operator from the dangerous components of machines that can be stopped immediately. It is not suitable for the machines whose operation cannot be stopped during the cycle operation or in a time shorter than the cycle itself.
Operation modes:	<ul style="list-style-type: none"> • Manual • Semi-automatic • Automatic
Safety category:	4 according to EN 954-1 – Type 4 (for HTB5, HTBR5, HTBL5, HTBLR5) 2 according to EN 954-1 – Type 2 (for HTB3, HTBR3, HTBL3, HTBLR3)
Resolution	14, 20, 30, 35, 40, 50 mm
Beam type and distance	Infrared with distance 10, 20, 30 mm
Protected height	80, 150, 300, 450, 600, 750, 900, 1050, 1200, 1350, 1500 mm
Useful capacity	0,1 ÷ 5,0 m (for HTB5, HTBR5, HTB3, HTBR3) 0.3 ÷ 17,0 m (for HTBL5, HTBLR5, HTBL3, HTBLR3)
Supply:	24 Vdc ± 20% (to be used only with AL05 feeder)
Absorbed power:	0.4 A max
Reply time:	< 30 ms up to 48 rays < 50,2 ms up to 96 rays
Inputs:	<ul style="list-style-type: none"> • RESTART • MUTING • TEST (excluding HTBR5, HTBLR5, HTBR3, HTBLR3)
Outputs:	2 safe outputs NA, 1 Adc max @ 30 Vdc (for HTB5, HTBR5, HTBL5, HTBLR5) 1 safe output NA, 1 Adc max @ 30 Vdc (for HTB3, HTBR3, HTBL3, HTBLR3)
Signal	Led (excluded HTBR3, HTBR5, HTBLR3, HTBLR5)
Protection degree:	IP 65
Installation configuration:	See Operation Manual Rev. 1.2

Optional:

- Feeder code HTB5 AL 01
- Feeder and safety relay, integrated code HTB5 AC 02
- Projector connecting cable L = 7 m code HTB5 CV 01
- Receiver connecting cable L = 7 m code HTB5 CV 02
- Cable for projector connection to receiver L = 5 m code HTB5 CV 03RP (for HTBR5, HTBLR5, HTBR3, HTBLR3)
- Fastening accessories code HTB5 ST 17, HTB5 ST 18
- Test cylinder, diameter 14, 20, 30, 35, 40, 50 mm cod. HTB5 CP 14, HTB5 CP 20, HTB5 CP 30, HTB5 CP 35, HTB5 CP 40, HTB5 CP 50

PRODUCT VERSIONS:

		Protected height xx [mm]										
		80	150	300	450	600	750	900	1050	1200	1350	1500
Resolution yy [mm]	14	•	•	•	•	•	•	•				
	20	•	•	•	•	•	•	•				
	30	•	•	•	•	•	•	•	•	•	•	•
	35	•	•	•	•	•	•	•	•	•	•	•
	40	•	•	•	•	•	•	•	•	•	•	•
	50	•	•	•	•	•	•	•	•	•	•	•

REFERENCES:

This Type EC Examination Certificate is issued regarding :

- Essential Safety and Health requirements indicated in the Annex I of the Directive 98/37/EC, applicable to the safety component/s as per this Type EC Examination Certificate.
- Specification applicable to the following European standards or draft standards :

UNI EN 954-1:1998	Machinery safety – Parts of the control system connected with the safety. Part 1: Main principles for the design
UNI EN 292-1:1992	Machinery safety – Basic criteria, general design principles. Part 1: Basic terminology, methodology
UNI EN 292-2:1992	Machinery safety – Fundamental concepts, general design principles. Part 2: Technical specifications and principles
CEI EN 61496-1:1998	Machinery safety – Electrosensitive protection equipment. Part 1: General requirements and tests
IEC 61496-2:1997	Safety of machinery – Electro-sensitive protective equipment Part 2: Particular requirements for equipment using active opto-electronic protective devices (AOPDs)

The type has been felt in compliance with the essential safety and health requirements, as established in Annex I of the Machinery Directive 98/37/EC.



**CERMET – NOTIFIED CERTIFICATION BODY
EUROPEAN NOTIFIED BODY N. 0476**

Authorized by the Industry, Commerce and Handicraft Ministry by Decree of July 28th, 1994 and Decree of May 21st, 2003, notified to the European Community Committee, issue the following

**TYPE EC EXAMINATION CERTIFICATE
ACCORDING TO THE DIRECTIVE 98/37/EC
N° 0476 B1 323 02 06**

for the following type/s of machine/s:

Trade Designation: Photoelectric safety barriers

Manufacturer: H.E.C.TO. SYSTEMS of Amato Salvatore & C. S.a.s.
Corso Grosseto, 194
10148 TORINO - Italy

Trade mark: H.E.C.TO.

Type/s: Red Beam series HTB5
Red Beam series HTB3

Applicant: H.E.C.TO. SYSTEMS of Amato Salvatore & C. S.a.s.
Corso Grosseto, 194
10148 TORINO - Italy

Dossier CERMET: C06E001

Issue date: 2006-02-17

General Manager
Ing. Rodolfo Trippodo

This Certificate only refers to the product indicated here above, manufactured according to the technical documentation delivered to CERMET. Any modification made on the product without the prior CERMET's approval makes it void. Any modifications made on the product/s shall be approved by CERMET, in accordance with article 5 of the Annex VI of the Directive 98/37/EC. This certificate does not imply that CERMET shall carry out a control on the production. This Certificate can be reproduced or duplicated integrally only

This Certificate consists of No. 3 sheets in all.

TECHNICAL CHARACTERISTICS:

<i>Model:</i>	Red Beam series HTB3, HTB5
<i>Product versions:</i>	HTBU3 xx rr, HTBU5 xx rr (<i>xx=protected height [mm], rr=ray number</i>) HTBS3 xx rr, HTBS5 xx rr (<i>xx=protected height [mm], rr=ray number</i>) HTBSR3 xx rr, HTBSR5 xx rr (<i>xx=protected height [mm], rr=ray number</i>)
<i>Year of manufacture:</i>	2006
<i>Use the product is destined for:</i>	The product is destined for the protection of the operator from the dangerous components of machines that can be stopped immediately. It is not suitable for the machines whose operation cannot be stopped during the cycle operation or in a time shorter than the cycle itself.
<i>Operation modes:</i>	<ul style="list-style-type: none"> • Manual (<i>except for HTBSR3, HTBSR5</i>) • Semi-automatic (<i>except for HTBSR3, HTBSR5</i>) • Automatic
<i>Safety category:</i>	4 according to EN 954-1 – Type 4 (<i>for HTBU5, HTBS5, HTBSR5</i>) 2 according to EN 954-1 – Type 2 (<i>for HTBU3, HTBS3, HTBSR3</i>)
<i>Useful capacity</i>	4 ÷ 60 m (<i>for HTBU5, HTBU3</i>) 0.2 ÷ 5 m (<i>for HTBS5, HTBSR5, HTBS3, HTBSR3</i>)
<i>Supply:</i>	24 Vdc ± 20% (<i>to be used only with AL05 feeder for models HTBU5, HTBS5, HTBSR5</i>)
<i>Absorbed power:</i>	0.8 A max (<i>for HTBU5, HTBS5, HTBSR5, HTBU3, HTBS3, HTBSR3</i>)
<i>Reply time:</i>	< 15 ms
<i>Inputs:</i>	<ul style="list-style-type: none"> • RESTART • MUTING • TEST (<i>excluding HTBSR5, HTBSR3</i>)
<i>Outputs:</i>	2 safe outputs NA, 1 Adc max @ 30 Vdc (<i>for HTBU5, HTBS5, HTBSR5</i>) 1 safe output NA, 1 Adc max @ 30 Vdc (<i>for HTBU3, HTBS3, HTBSR3</i>)
<i>Protection degree:</i>	IP 65
<i>Installation configuration:</i>	See Operation Manual Rev. 1.3
<i>Optional:</i>	<ul style="list-style-type: none"> • Feeder code HTB5 AL 01 • Feeder and safety relay, integrated code HTB5 AC 02 • Projector connecting cable L = 7 m code HTB5 CV 01 • Receiver connecting cable L = 7 m code HTB5 CV 02 • Cable for projector connection to receiver L = 5 m code HTB5 CPV 02/CPR2 (<i>for HTBR5, HTBLR5, HTBR3, HTBLR3</i>) • Fastening accessories code HTB5 ST 17, HTB5 ST 18 • Test cylinder, diameter 14, 20, 30, 35, 40, 50 mm cod. HTB5 CP 14, HTB5 CP 20, HTB5 CP 14 HTB5 CP 30, HTB5 CP 35, HTB5 CP 40, HTB5 CP 50

PRODUCT VERSIONS:

For HTBU5, HTBS5, HTBSR5, HTBU3, HTBS3, HTBSR3:

Ray No.	Protected height xx [mm]													
	160	300	450	600	750	900	1050	1200	1350	1500	1650	1800	1950	
1	•													
2		•	•	•	•	•	•	•	•	•				
3		•	•	•	•	•	•	•	•	•				
4		•	•	•	•	•	•	•	•	•	•	•	•	•

REFERENCES:

This Type EC Examination Certificate is issued regarding :

- Essential Safety and Health requirements indicated in the Annex I of the Directive 98/37/EC, applicable to the safety component/s as per this Type EC Examination Certificate.
- Specification applicable to the following European standards or draft standards :

UNI EN 954-1: 1998	Machinery safety – Parts of the control system connected with the safety. Part 1: Main principles for the design
UNI EN 292-1:1992	Machinery safety – Basic criteria, general design principles. Part 1: Basic terminology, methodology
UNI EN 292-2:1992	Machinery safety – Fundamental concepts, general design principles. Part 2: Technical specifications and principles
CEI EN 61496-1:1998	Machinery safety – Electrosensitive protection equipment. Part 1: General requirements and tests
IEC 61496-2:1997	Safety of machinery – Electro-sensitive protective equipment Part 2: Particular requirements for equipment using active opto-electronic protective devices (AOPDs)

The type has been felt in compliance with the essential safety and health requirements, as established in Annex I of the Machinery Directive 98/37/EC.



HECTO SYSTEMS sas
C.so Grosseto, 194 - 10148 Torino Italy
Tel. +39 011 274 51 40 - Fax +39 011 229 11 23

www.hectosystems.it
hecto@hectosystems.it