

# BALLUFF

## **Micropulse BIW** Inductive Linear Position Sensor

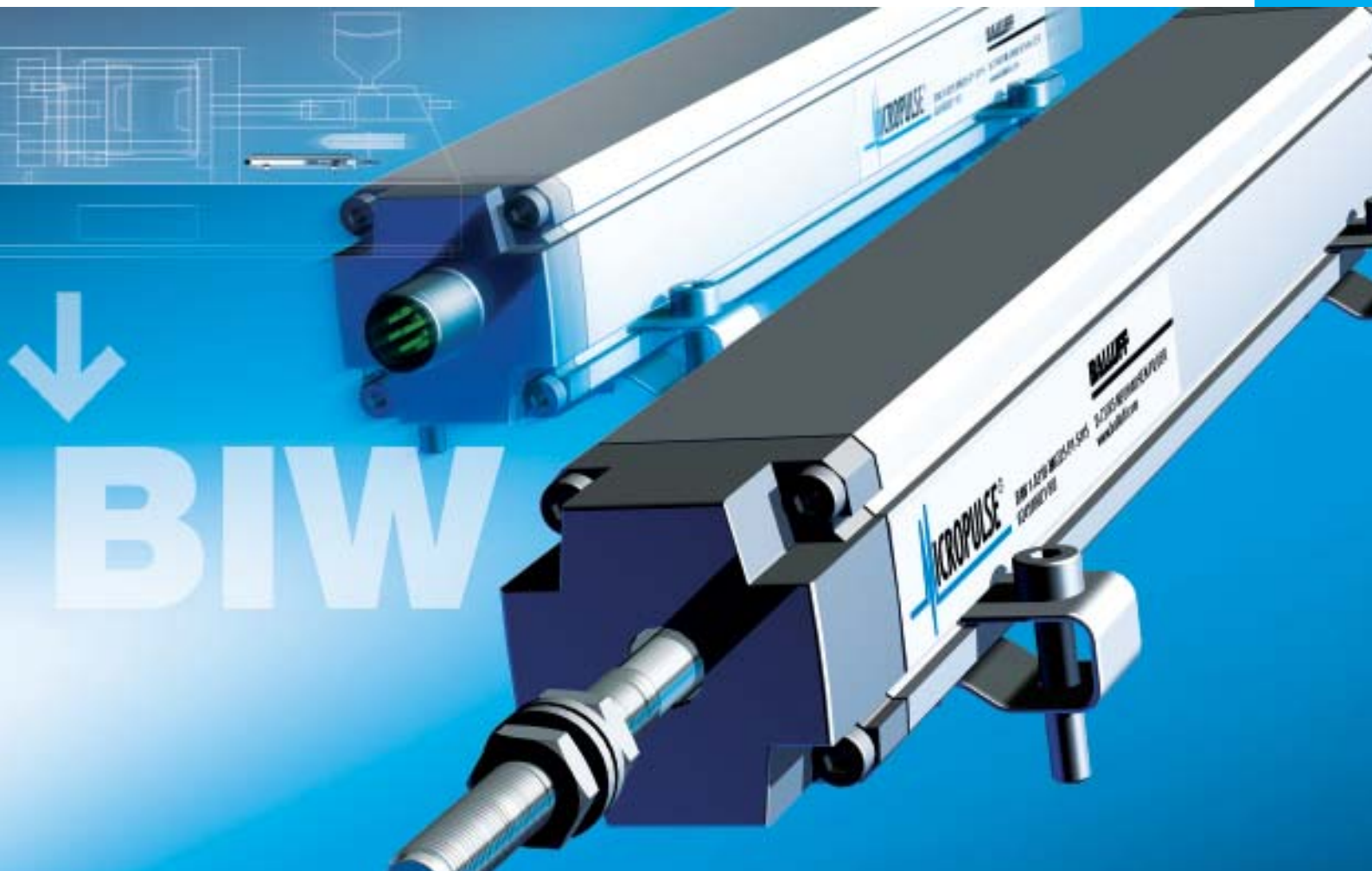

The BIW inductive linear position transducer is based on a new, patented principle of operation which detects the measured position without contact.

The BIW transducer contains a sender / receiver element and an oscillator protected by an extruded aluminum housing. The oscillator is attached to a sliding rod which is in turn attached to the moving member of the machine or equipment.

The oscillator is excited by the sender component at a sampling rate of 20 kHz and couples the current position signal into the receiver element. The position is immediately available on the output as an absolute analog value.

The direction of the output signal – rising or falling – can be determined by how the output slope connections are made.

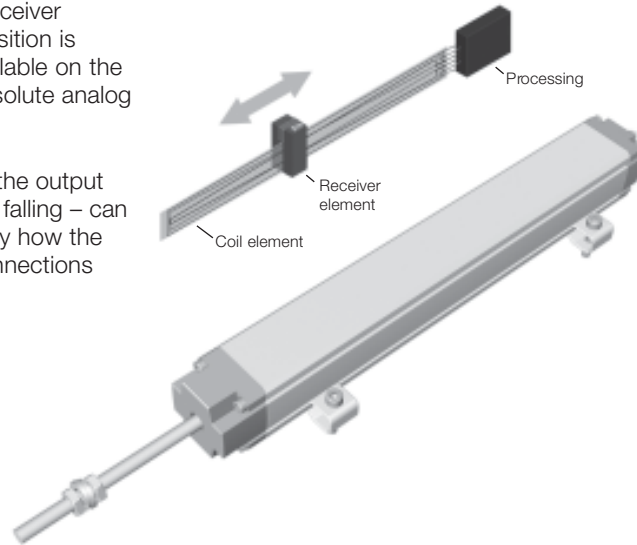

### Characteristics

BIW feature:

- High resolution and repeatability
- Resistance to shock, vibration and noise fields
- An absolute rising or falling analog output signal
- A guided sensor element
- 20 kHz update rate
- Potential-free
- A non-contacting measuring principle

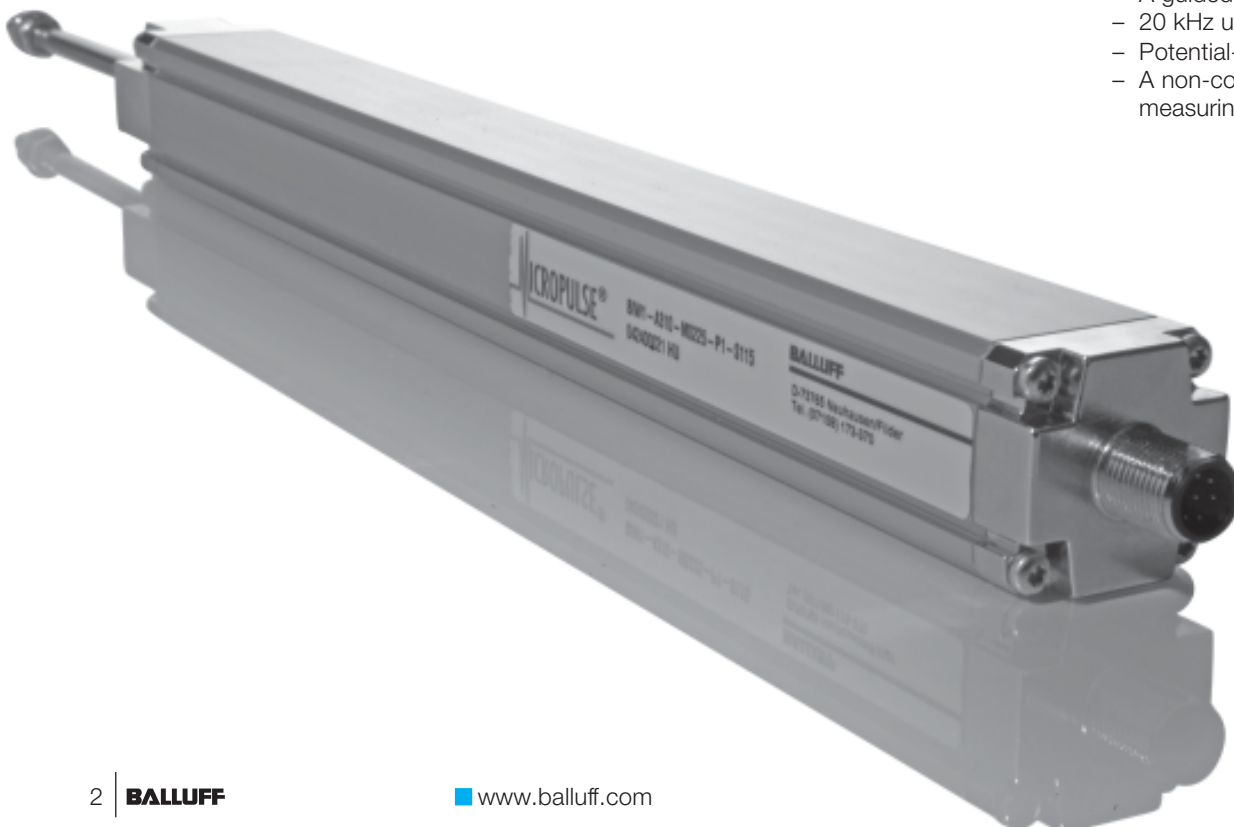

Series	<b>BIW</b>
Output signal	analog
Transducer interface	<b>A/G</b>
Input interface	analog

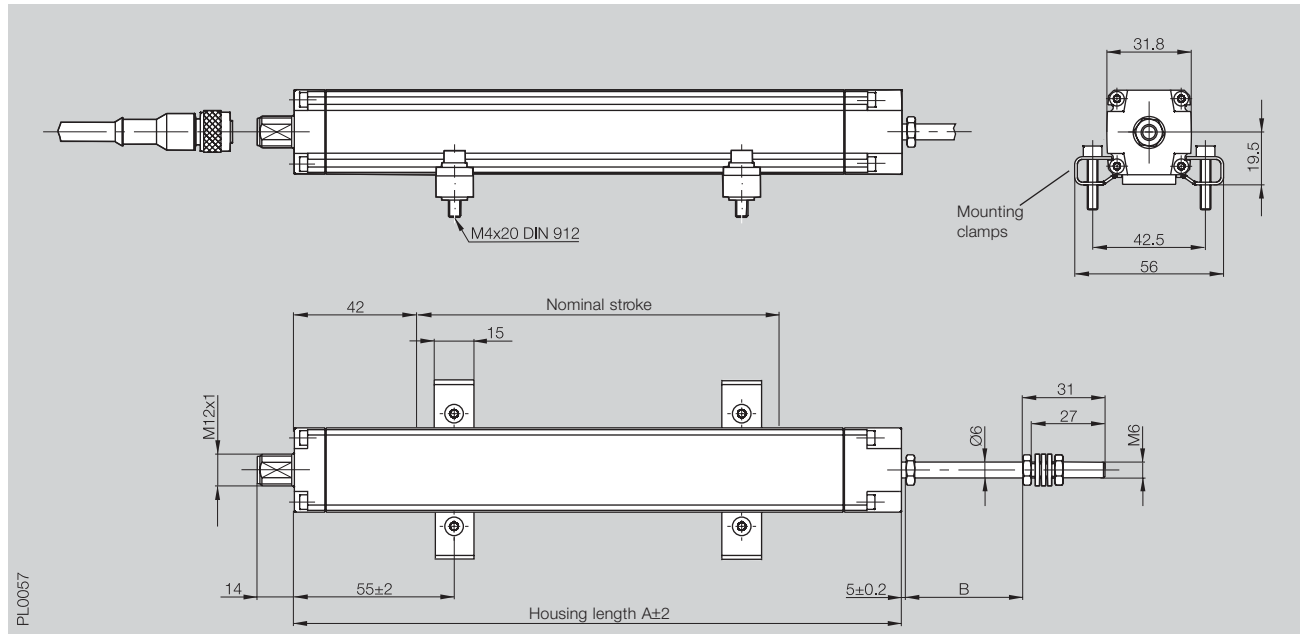

Ordering code	<b>BIW1-A/G310-M _ _ _ -P1-S115</b>	
Output signal A	0...+10 V	
Output signal G	-10...+10 V	
max. current load per output	6 mA	
System resolution	5 µm	
Repeatability	10 µm	
non-linearity	≤ ±200 µm bis 500 mm nominal stroke typ. ±0,02 %, max. ±0,04 % 500...750 mm nominal stroke	
Sampling rate	typ. 20 kHz	
Supply voltage	18...30 V DC	
No-load current	≤ 60 mA	
Operating temperature	-20...+85 °C	
Storage temperature	-40...+100 °C	
Pin assignments	Pin 1 YE	Slope selector
	Pin 2 GY	0 V
	Pin 3 PK	reserved
	Pin 4 RD	Slope selector
	Pin 5 GN	0...+10 V oder -10...+10 V
	Pin 6 BU	GND
	Pin 7 BN	+24 V DC
	Pin 8 WH	reserved
Shock load	100 g/2 ms	
Vibration	12 g, 10...2000 Hz	
Dielectric strength	500 V (GND to housing)	
Enclosure rating per IEC 60529	IP 54	
Housing material	Anodized aluminum	
Mounting	Mounting clamps	
Connection type	Connector M12, 8-pin standard	
Housing length A	Nominal stroke + 100 mm	
Mechanical stroke B	Nominal stroke + 10 mm	

- Included:
- Transducer
  - User's guide
  - 2 Mounting clamps
  - BIW-A-MF01-M-43

Ordering example:

**BIW1- 310-M \_ \_ \_ -P1-S115**

**Data protocol**

**Standard nominal strokes [mm]**

A 0...+10 V

0075, 0100, 0130, 0150, 0175,

G -10...+10 V

0225, 0300, 0360, 0375, 0400,  
0450, 0500, 0600, 0650, 0750

Connectors/accessories for series	<b>BKS-S115-PU-</b> __ BIW-__-S115	<b>BKS-S116-PU-</b> __ BIW-__-S115	<b>BKS-S115-00</b> BIW-__-S115
Type	8-pin, Straight, female	8-pin, Right angle, female	8-pin, female

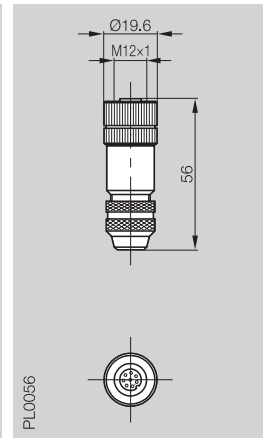
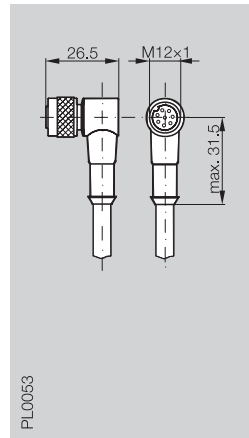
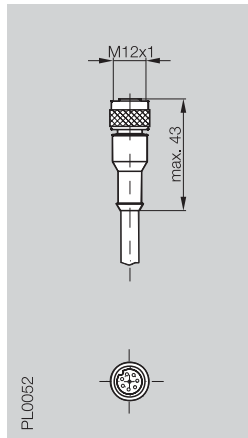

Ordering code	<b>BKS-S115-PU-</b> __	<b>BKS-S116-PU-</b> __	<b>BKS-S115-00</b>
Screw terminal			max. 0,75 mm <sup>2</sup>
Housing material	PUR	PUR	CuZn nickel plated
Contacts	CuZn	CuZn	CuZn
Contact finish	0,8 µm Au	0,8 µm Au	
Cable strain relief			PG 9
Cable diameter			6...8 mm
Enclosure rating per IEC 60529	IP 67	IP 67	IP 67 (when attached)
Knurled coupling ring	CuZn	CuZn	
Finish	2,5 µm Ni	2,5 µm Ni	
O-ring	Viton	Viton	Viton
Cable	Molded-on PUR		
No. of wires × conductor cross section	8×0,25 mm <sup>2</sup>		
Type	LIYY-CF11Y		
Conductor configuration	14 × 0,15 mm		
Outer diameter	6,6 ±0,2 mm		
Min. bending radius	dynamic 4 × D, static 3 × D		

Please indicate cable length in ordering code!

02 = Length 2 m; 05 = Length 5 m;  
10 = Length 10 m; 15 = Length 15 m;  
20 = Length 20 m; 25 = Length 25 m

Pin assignments	Pin	Color
	1	YE
	2	GY
	3	PK
	4	RD
	5	GN
	6	BU
View of female	8	WH

Adapter BKS-S115 to BKS-S32  
Ordering code: BKS-S115/GS32-PU-00,2



See other transducers in the BTL main catalog, on the CD-ROM or online!

[www.balluff.com](http://www.balluff.com)

Balluff GmbH  
Schurwaldstrasse 9  
73765 Neuhausen a.d.F.  
Germany  
Phone +49 (0) 71 58/1 73-0  
Fax +49 (0) 71 58/50 10  
E-Mail: balluff@balluff.de